

12" Oil Catch Mufflers | Vertical Orientation Bolt-In Carbon Steel with Filter

12" Vertical Oil Catch Muffler

** 12" Diameter - TO 500 CFM

FEATURES:

- Bolted Closure
- 3/8" Buna O-Ring
- 1" Ball Valve Drain
- Pleated Stainless Steel Filter



12" Oil Catch Mufflers Vertical Orientation Bolt Carbon Steel w/Filter | Parts List

PART NUMBER	DESCRIPTION	WEIGHT	PRICE
212-120-3NPT	12" OIL CATCH MUFFLER W/ FILTER, 3" NPT	71 LBS	
212-120-4NPT	12" OIL CATCH MUFFLER W/ FILTER, 4" NPT	71 LBS	

12" Oil Catch Mufflers Vertical Orientation Bolt Carbon Steel w/Filter | Replacement Parts

PART NUMBER	DESCRIPTION
288-100	1" BALL VALVE DRAIN
286-375-RND-PF	12" BUNA O-RING

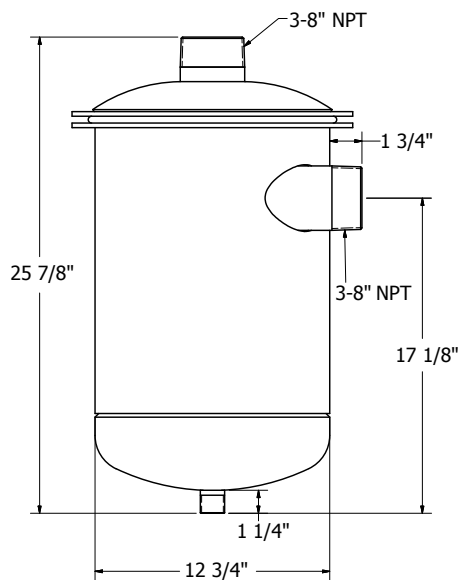

Genuine National Vacuum Equipment Products Proudly Distributed By *Armstrong Equipment Inc.*

800-699-7557