

SHURFLO® MODEL 100 SINGLE FIXTURE PUMP

INSTALLATION & OPERATION MANUAL

⚠ WARNING: Never operate the pump in an explosive environment. Arcing from the switch, motor brushes, or heat from the motor may cause an explosion. The Model 100 Nautilus is ISO 8846 and U/L Marine listed (ignition protected) for non-flammable liquids.

⚠ CAUTION: Model 100 pump should be only used in **positive prime (flooded inlet) applications**. Permanent damage will occur to the shaft seal if run dry. Maximum dry run time is less than one minute. Failure due to dry running is not covered by SHURFLO's limited warranty.

⚠ CAUTION: DO NOT assume pump compatibility with fluids other than water. If fluid is incompatible with pump materials, leaks may occur. SHURFLO offers other pump models for various applications. Contact SHURFLO for compatibility or application information.

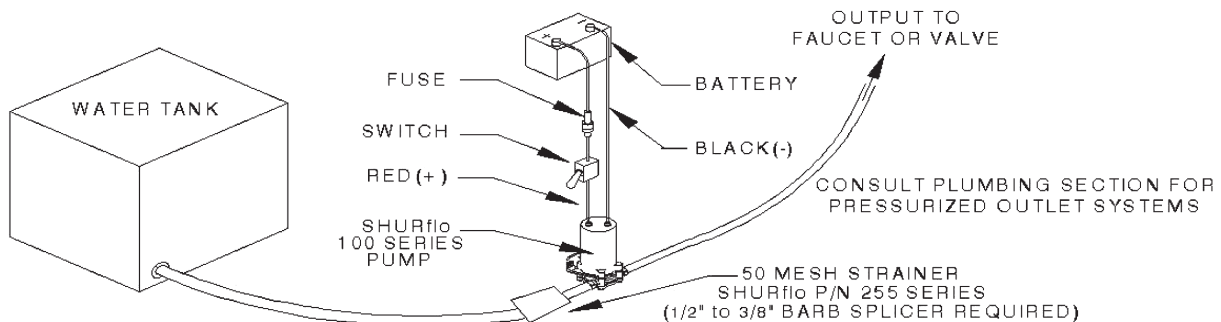

MOUNTING

The pump may be mounted in any position. **Always mount the pump level or below the bottom of the water tank. The pump should be as close as possible to the tank.** If there is positive head pressure from the water tank to the pump inlet, the pump will prime. If mounted above the lowest water level, the pump may require forced priming before operation. Never mount the pump more than 4 inches [10 cm] above the lowest water level. Secure the pump with screws through the rubber grommets (do not over compress). Use thread-locking compounds on machine screws if necessary.

ELECTRICAL

The pump should be on a dedicated (individual) circuit, and must be protected by a fuse/circuit breaker as listed on motor label. The positive (+) side should be fused between the power supply and on/off switch.

NOTE: Failure to provide proper overload/temperature safety devices may lead to motor failure that is not covered by SHURFLO's limited warranty. Always install the pump per local and state electrical wiring codes. A switch rated at or above 3.0 amps is recommended and must interrupt current flow on the positive (+) red) lead. Marine applications should use a U/L Marine approved (ignition protected) switch. Recommended wire size is 16 gauge or larger [1.2 Mm²] wire. Negative (-) should be connected to a known ground. Ground wire must be the same (gauge/Mm²) as the positive wire.

PLUMBING

When positive pressure is fed into the output plumbing (city water entry, water heater, etc.), it is necessary to install a one-way check valve (SHURFLO P/N 340-001) after the pump. With positive pressure plumbed into the output side of the system all tubing and components should be suitable for higher pressure. Use flexible 3/8" I.D. [10mm] tubing with a pressure rating of 25 psi [1.7 bar] or higher. Tubing clamps should be used to secure the tubing over the barb fittings. Never plumb the pump with excessive stress on either port that could cause damage. A 50-mesh strainer is essential to prevent foreign debris from entering the pump. The strainer should be installed within the inlet tubing between tank and pump inlet. Failure due to foreign debris is not covered by SHURFLO's limited warranty.

NOTE: Never use ABS cement, pipe dope, or Teflon tape on inlet tubing. Foreign debris that enters the pump may cause premature pump failure or excess current. At zero head, open flow will be approximately one gallon per minute [4 lt/min]. Maximum pressure is 10 psi [.68 bar] at zero flow.



WATER PURIFICATION

3545 HARBOR GATEWAY SOUTH, SUITE 103, COSTA MESA, CA 92626, (800) 854-3218 WWW.SHURFLO.COM

All Pentair trademarks and logos are owned by Pentair, Inc. All other brand or product names are trademarks or registered marks of their respective owners. Because we are continuously improving our products and services, Pentair reserves the right to change specifications without prior notice. Pentair is an equal opportunity employer.