

Proudly Distributed By:

ARMSTRONG EQUIPMENT INC.



MADE IN THE USA



43 Series Product Catalog

NVE
National Vacuum Equipment

Challenger Series
VACUUM PUMPS & BLOWERS

Table Of Contents

3	4307 High Vacuum Tri-Lobe Blowers
4	4310 High Vacuum Tri-Lobe Blowers
5	Pro Pak - Frame Mount Gearbox Drive
6	Pro Pak - Frame Mount Hydraulic Drive
7	Pro Pak - Fame Mount Belt Drive
8	Pro Pak - Top Mount Hydraulic or Belt Drive
9	Belly Mount Trailer Package Hydraulic Drive
10	4307 Manifold Diagram
11	4310 Manifold Diagram
12	Components & Accessories

S
T
E
N
T
E
N
T
C
O
N
T
E
N
T
S



4307 High Vacuum Tri-Lobe Blowers Challenger Series

Features

- Continuous duty performance at maximum vacuum
- Tri-lobe design with precision machining
- Ballast port manifold
 - cools blower through air injection
- Range of airflow
 - performance available to accommodate power
- Oil-less operation
- 4" hose barbed adjustable porting for intake and exhaust
- Integral final filter with easy access cleaning
- 4-Way pressure/vacuum change over valve
- Designed, built, and supported in the USA

4307 CHALLENGER BLOWER | SPECIFICATIONS

Air Flow - Free Air	560 CFM
*Full Vacuum	
Maximum Intermittent Pressure	15 PSI
*Operating Speed - Recommended	4000 RPM
Hp Required @ 27" hg	36.4
Hp Required @ 10 psi	28.4
Hp Required @ 15 psi	40.6
Porting Size	4"
Shaft Size (3/8" key)	1 1/2"

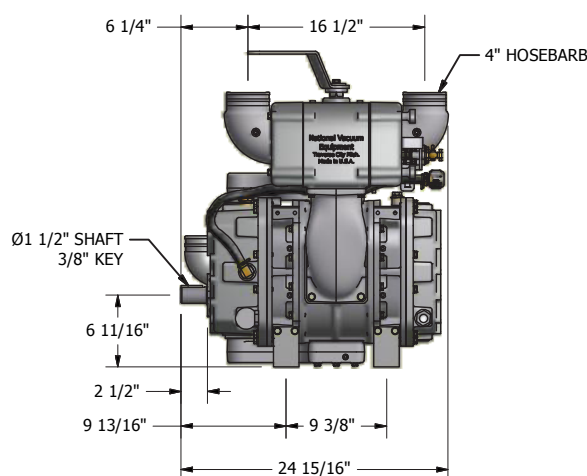
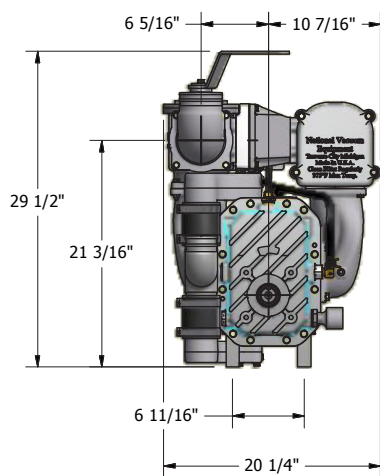
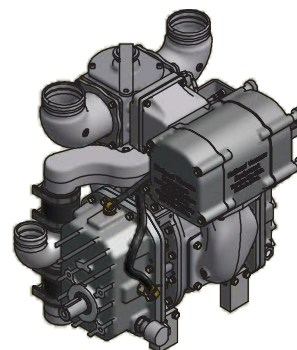

PRODUCT DESCRIPTION	PART NUMBER	WEIGHT	MSRP
Challenger 4307 Blower (Bare Shaft) - CW	131-4307-LD	321 lbs	\$6,174.85
Challenger 4307 Blower (Bare Shaft) - CCW	131-4307-LS	321 lbs	\$6,174.85
Challenger 4307 Blower with Manifold and Ballast - CW (Pictured Above)	131-4307-LDM	421 lbs	\$7,364.50
Challenger 4307 Blower with Manifold and Ballast - CCW	131-4307-LSM	421 lbs	\$7,364.50

*The maximum allowable operating vacuum will vary depending on R.P.M., ambient temperature, altitude and time running. The basic principle to keep in mind is - faster R.P.M., higher air temperature and longer run time all equal more heat in blower. When installing an NVE 4307 or 4310 blower we recommend a normal R.P.M. of 4000. Other speeds are ok as long as exhaust gas temperatures read on the supplied thermometer do not exceed 380 degrees F.

4310 High Vacuum Tri-Lobe Blowers

Features

- Continuous duty performance at maximum vacuum
- Tri-lobe design with precision machining
- Ballast port manifold
 - cools blower through air injection
- Range of airflow
 - performance available to accommodate power
- Oil-less operation
- 4" hose barbed adjustable porting for intake and exhaust
- Integral final filter with easy access cleaning
- 4-Way pressure/vacuum change over valve
- Designed, built, and supported in the USA

4310 CHALLENGER BLOWER SPECIFICATIONS

Air Flow - Free Air	940 CFM at 4500 RPM	
*Full Vacuum		
Maximum Intermittent Pressure	15 PSI	
*Operating Speed - recommended	4000 RPM	4500 RPM
HP Required @ 27" Hg	51.4	58
HP Required @ 10 psi	39.7	44
HP Required @ 15 PSI	65.5	
Porting Size	4"	
Shaft Size (3/8" Key)	1 1/2"	
Approximate Weight	456 lbs	

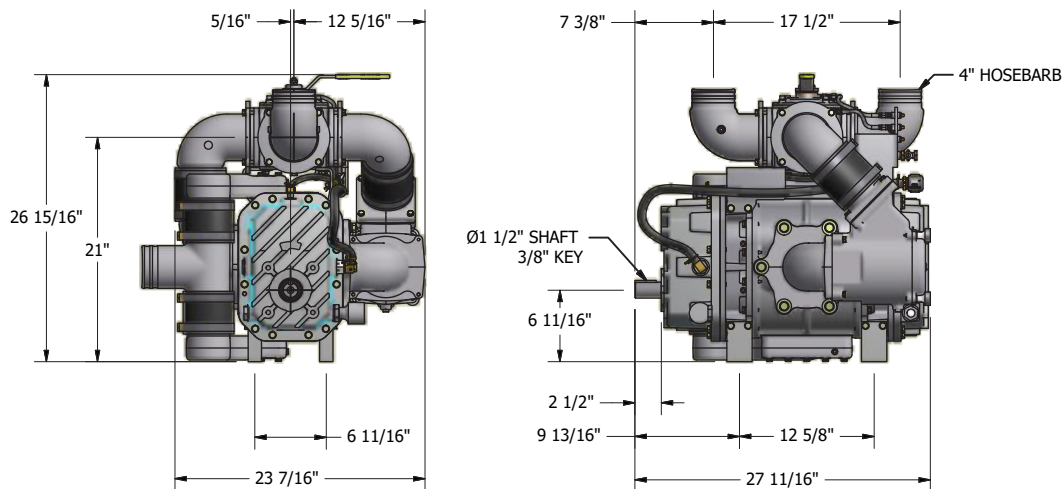
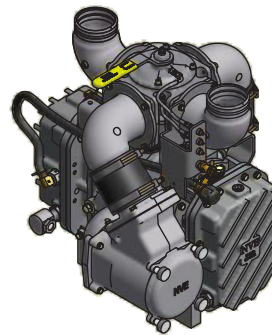

PRODUCT DESCRIPTION	PART NUMBER	WEIGHT	MSRP
Challenger 4310 Blower (Bare Shaft) - CW	131-4310-LD	349 lbs	\$7,173.95
Challenger 4310 Blower (Bare Shaft) - CCW	131-4310-LS	349 lbs	\$7,173.95
Challenger 4310 Blower with Manifold and Ballast - CW (Pictured Above)	131-4310-LDM	456 lbs	\$8,343.00
Challenger 4310 Blower with Manifold and Ballast - CCW	131-4310-LSM	456 lbs	\$8,343.00

*The maximum allowable operating vacuum will vary depending on R.P.M., ambient temperature, altitude and time running. The basic principle to keep in mind is - faster R.P.M., higher air temperature and longer run time all equal more heat in blower. When installing an NVE 4307 or 4310 blower we recommend a normal R.P.M. of 4000. Other speeds are ok as long as exhaust gas temperatures read on the supplied thermometer do not exceed 380 degrees F. Maximum of 4500 R.P.M is for intermittent use only.

43 Series Packages Pro Pak Frame Mount Gearbox Drive

Challenger Series



Features

- 3/8" powder coat painted frame
- Stainless steel cabinet
- Easily accessible service points
- Blower flush kit
- Internal ballast silencing
- Ballast check valve for pressure operation
- 500 series right angle 1:2 ratio gearbox
 - 4307 - straight cut gear
 - 4310 - spiral beveled gear
- Designed, built, and supported in the USA

Blower is available with
Pneumatic Actuator

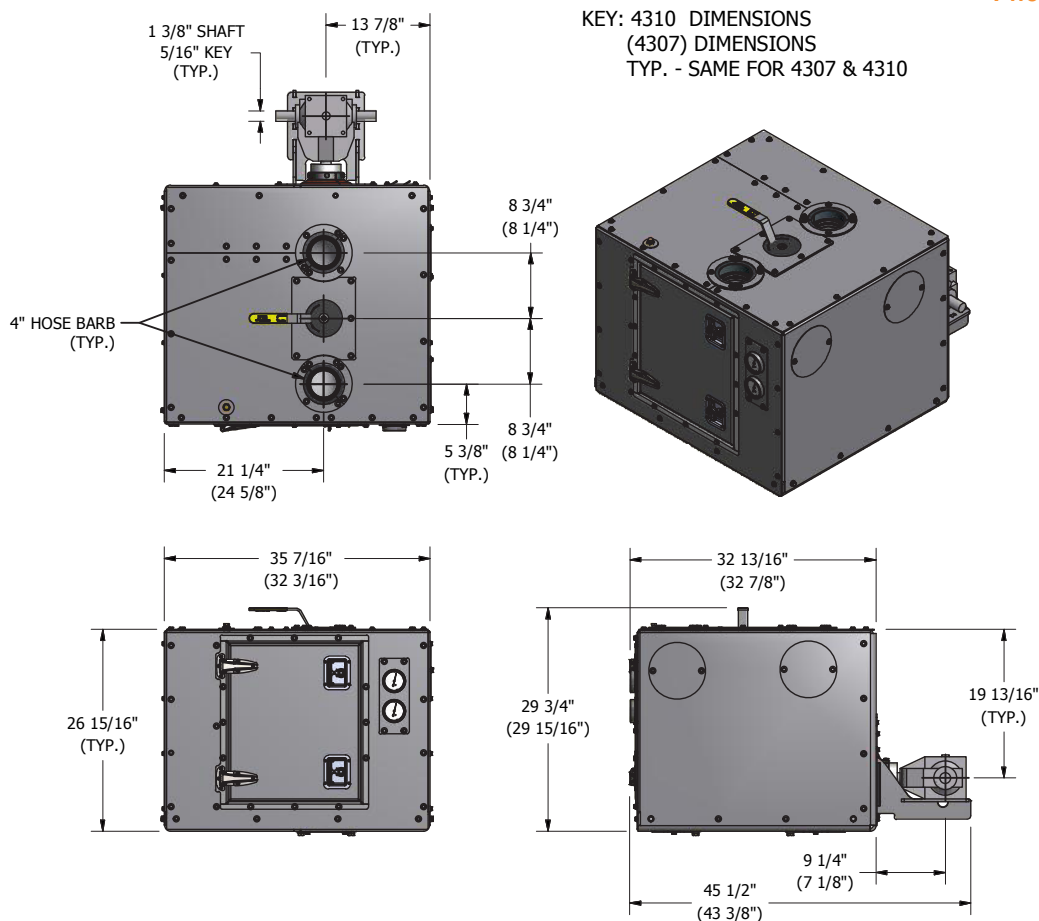

PRODUCT DESCRIPTION	PART NUMBER	WEIGHT	MSRP
4307 FM GB DR Enclosed Base Unit (Pictured Above)	147-4307-400	932 lbs	\$12,617.50
4307 FM GB DR Enclosed - Ballast Silencer w/Exhaust Silencer	147-4307-405	1147 lbs	\$13,158.25
4307 FM GB DR Enclosed - Ballast Silencer w/Round Silencer	147-4307-410	1115 lbs	\$13,158.25
4307 FM GB DR Enclosed - Ballast Silencer w/Ultra Silencer	147-4307-415	1152 lbs	\$13,853.50
4307 FM GB DR Enclosed - Ballast Silencer w/Moisture Trap	147-4307-420	1003 lbs	\$13,220.05
4307 FM GB DR Enclosed - Ballast Silencer w/Moisture Trap & Round Silencer	147-4307-425	1197 lbs	\$14,224.30
4307 FM GB DR Enclosed - Ballast Silencer w/Moisture Trap & Ultra Silencer	147-4307-430	1234 lbs	\$14,919.55
4310 FM GB DR Enclosed Base Unit (Pictured Above)	147-4310-400	1012 lbs	\$14,677.50
4310 FM GB DR Enclosed - Ballast Silencer w/Round Silencer	147-4310-410	1178 lbs	\$15,681.75
4310 FM GB DR Enclosed - Ballast Silencer w/Ultra Silencer	147-4310-415	1215 lbs	\$16,377.00

43 Series Packages

Pro Pak - Frame Mount Hydraulic Drive

Features

- 3/8" powder coat painted frame
- Stainless steel cabinet
- Easily accessible service points
- Blower flush kit
- Internal ballast silencing
- Ballast check valve for pressure operation
- SAE C face hydraulic adapter
- Designed, built, and supported in the USA

*Blower is available with
Pneumatic Actuator*

KEY: 4310 DIMENSIONS
(4307) DIMENSIONS
TYP. - SAME FOR 4307 & 4310

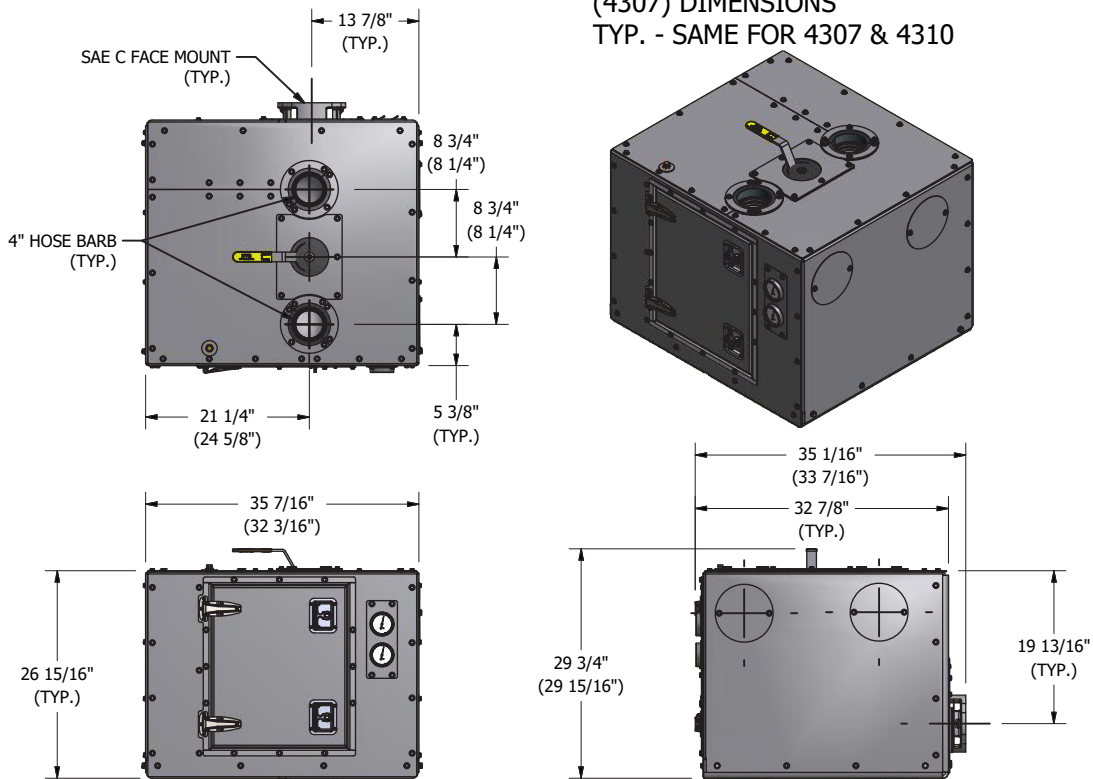

PRODUCT DESCRIPTION	PART NUMBER	WEIGHT	MSRP
4307 FM HYD DR Enclosed Base Unit (Pictured Above)	147-4307-435	858 lbs	\$11,433.00
4307 FM HYD DR Enclosed - Ballast Silencer w/Round Silencer	147-4307-445	1052 lbs	\$12,437.25
4307 FM HYD DR Enclosed - Ballast Silencer w/Ultra Silencer	147-4307-450	1089 lbs	\$13,132.50
4307 FM HYD DR Enclosed - Ballast Silencer w/Moisture Trap	147-4307-455	940 lbs	\$12,499.05
4307 FM HYD DR Enclosed - Ballast Silencer w/Moisture Trap & Round Silencer	147-4307-460	1134 lbs	\$13,503.30
4307 FM HYD DR Enclosed - Ballast Silencer w/Moisture Trap & Ultra Silencer	147-4307-465	1171 lbs	\$14,198.55
4310 FM HYD DR Enclosed Base Unit (Pictured Above)	147-4310-435	921 lbs	\$13,647.50
4310 FM HYD DR Enclosed - Ballast Silencer w/Round Silencer	147-4310-445	1115 lbs	\$14,651.75
4310 FM HYD DR Enclosed - Ballast Silencer w/Ultra Silencer	147-4310-450	1152 lbs	\$15,347.00

43 Series Packages Pro Pak - Frame Mount Belt Drive

Challenger Series



Features

- 3/8" powder coat painted frame
- Stainless steel cabinet
- Easily accessible service points
- Blower flush kit
- Internal ballast silencing
- Ballast check valve for pressure operation
- Belt drive is 2.5:1 speed up ratio
- Designed, built, and supported in the USA

Blower is available with
Pneumatic Actuator

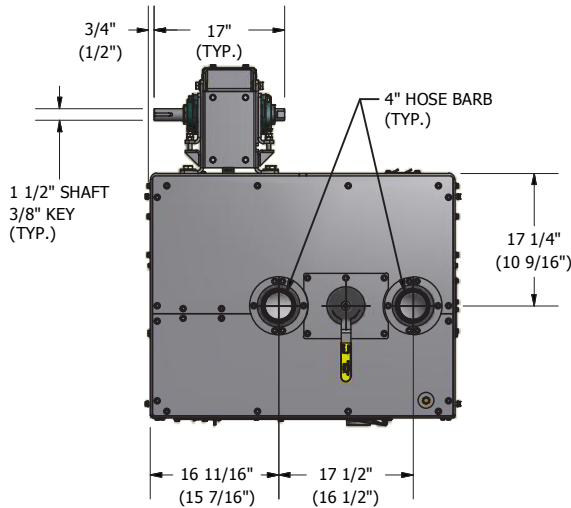

KEY: 4310 DIMENSIONS
(4307) DIMENSIONS
TYP. - SAME FOR 4307 & 4310

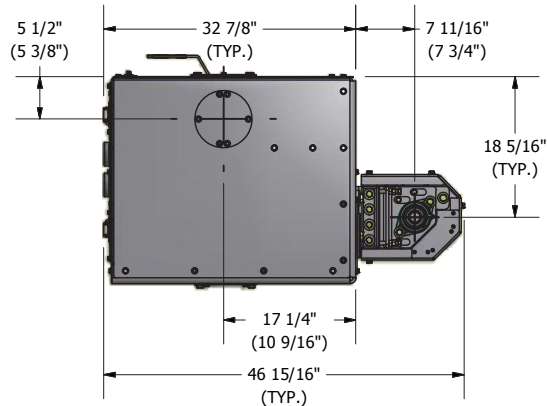
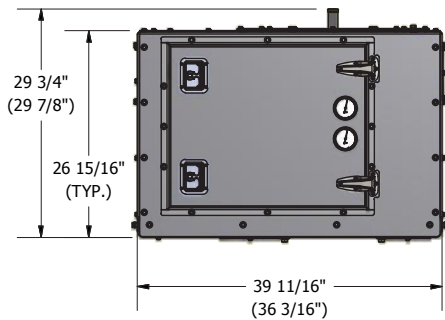
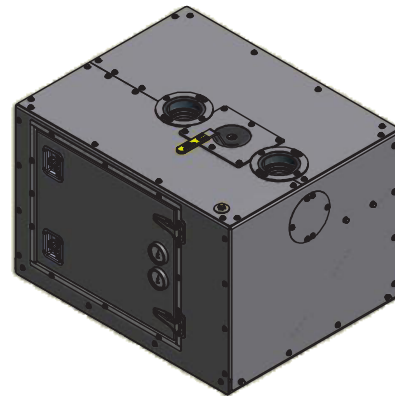

PRODUCT DESCRIPTION	PART NUMBER	WEIGHT	MSRP
4307 FM BELT DR CW Enclosed Base Unit (Pictured Above)	147-4307-500	980 lbs	\$13,493.00
4307 FM BELT DR CCW Enclosed Base Unit	147-4307-505	980 lbs	\$13,493.00
4307 FM BELT DR CW Enclosed - Ballast Silencer w/Round Silencer	147-4307-510	1174 lbs	\$14,497.25
4307 FM BELT DR CW Enclosed - Ballast Silencer w/Ultra Silencer	147-4307-515	1211 lbs	\$15,141.00
4310 FM BELT DR CW Enclosed Base Unit (Pictured Above)	147-4310-500	1027 lbs	\$15,553.00
4310 FM BELT DR CCW Enclosed Base Unit	147-4310-505	1027 lbs	\$15,553.00
4310 FM BELT DR CW Enclosed - Ballast Silencer w/Round Silencer	147-4310-510	1221 lbs	\$16,557.25
4310 FM BELT DR CW Enclosed - Ballast Silencer w/Ultra Silencer	147-4310-515	1258 lbs	\$17,201.00

43 Series Packages

Pro Pak - Top Mount Hydraulic or Belt Drive

Features

- 3/8" powder coat painted frame
- Stainless steel cabinet
- Easily accessible service points
- Blower flush kit
- Internal ballast silencing
- Ballast check valve for pressure operation
- SAE C face hydraulic adapter
- Designed, built, and supported in the USA

*Blower is available with
Pneumatic Actuator*

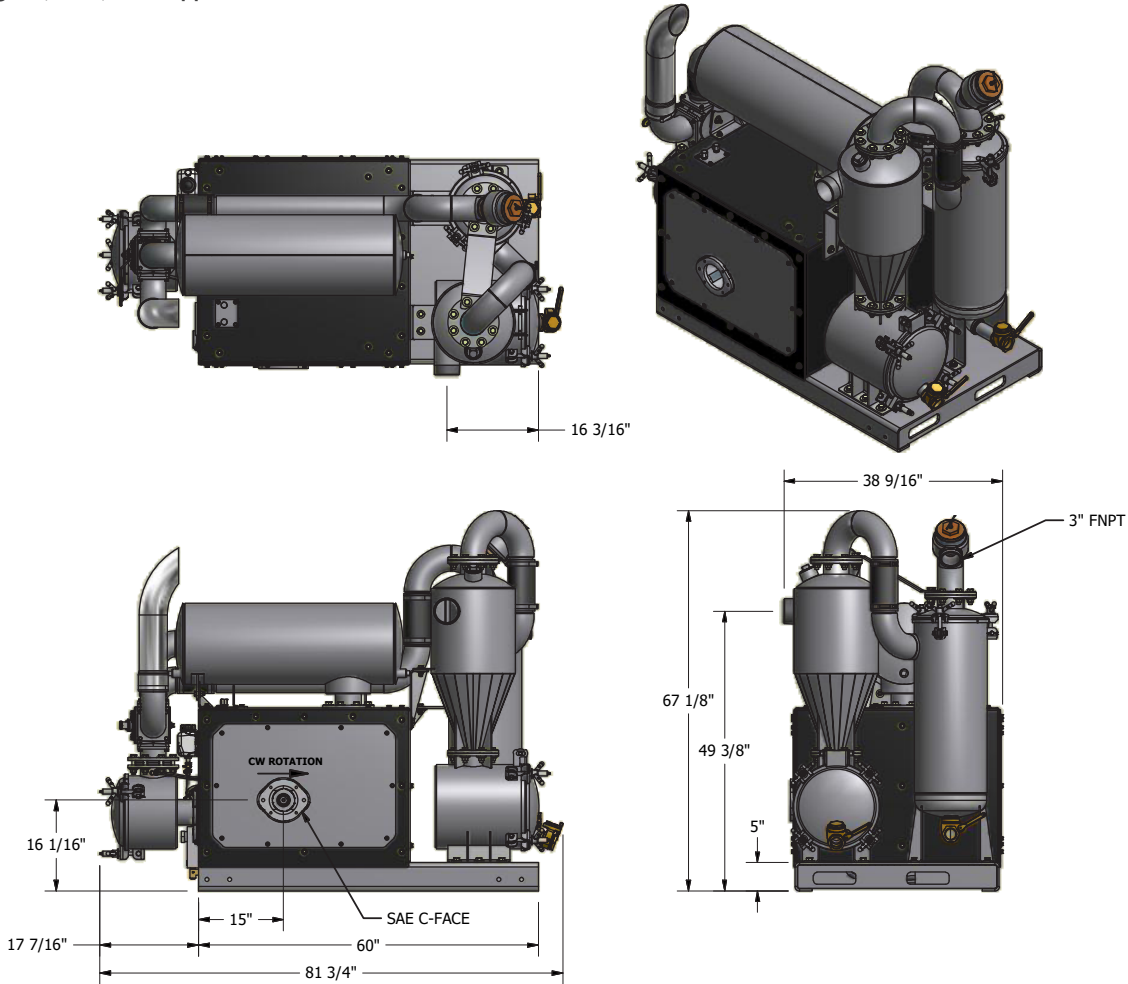

PRODUCT DESCRIPTION	PART NUMBER	WEIGHT	MSRP
4307 Top Mount Hydraulic Drive	147-4307-470	1469 lbs	\$12,360.00
4307 Top Mount Hydraulic Drive w/Moisture Trap & Cyclone	147-4307-475	1944 lbs	\$14,677.50
4307 Top Mount Belt Drive	147-4307-480	1570 lbs	\$13,853.50
4307 Top Mount Belt Drive w/Moisture Trap & Cyclone	147-4307-485	2045 lbs	\$16,068.00
4310 Top Mount Hydraulic Drive	147-4310-470	1539 lbs	\$13,390.00
4310 Top Mount Hydraulic Drive w/Moisture Trap & Cyclone (Pictured Above)	147-4310-475	2483 lbs	\$16,068.00
4310 Top Mount Belt Drive	147-4310-480	1640 lbs	\$14,883.50
4310 Top Mount Belt Drive w/Moisture Trap & Cyclone CW input from PTO	147-4310-485	2584 lbs	\$17,098.00
4310 Top Mount Belt Drive w/Moisture Trap & Cyclone CCW input from PTO	147-4310-486	2584 lbs	\$17,098.00

43 Series Packages Belly Mount Trailer Package Hydraulic Drive

Challenger Series



Features

- 3/8" powder coat painted frame
- Stainless steel cabinet
- Easily accessible service points
- Blower flush kit
- Internal ballast silencing
- Ballast check valve for pressure operation
- Belt drive is 2.5:1 speed up ratio
- Designed, built, and supported in the USA

Blower is available with Pneumatic Actuator

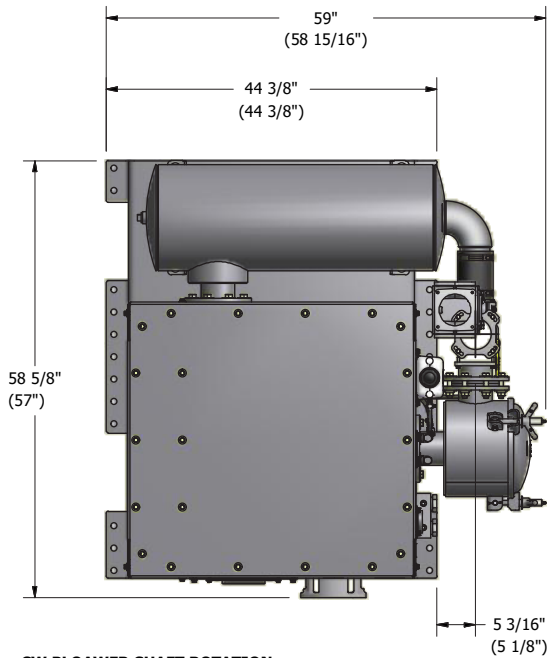

KEY: 4310 DIMENSIONS
(4307) DIMENSIONS
TYP. - SAME FOR 4307 & 4310

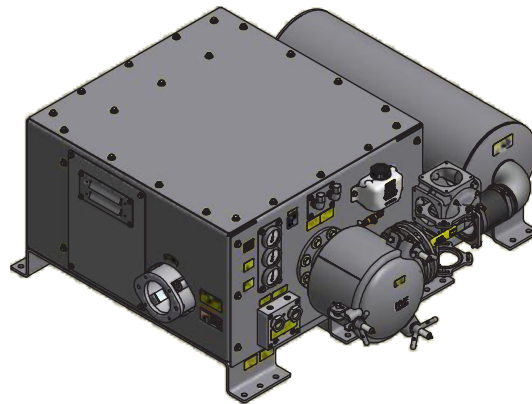

CW BLOWER SHAFT ROTATION

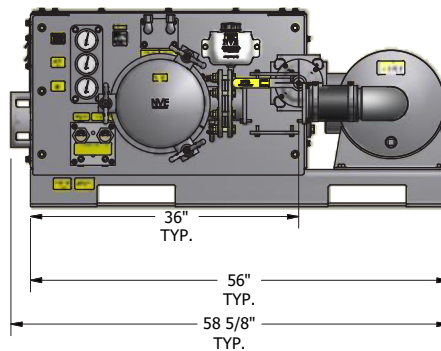
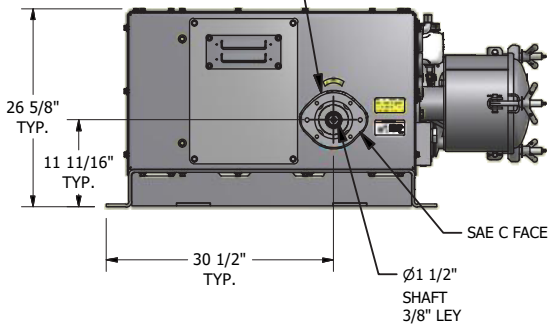

PRODUCT DESCRIPTION	PART NUMBER	WEIGHT	MSRP
4307 Belly Mount HYD DR Trailer Package	147-4307-490	1378 lbs	\$13,390.00
4310 Belly Mount HYD DR Trailer Package	147-4310-490	1448 lbs	\$14,420.00

4307 Manifold | Parts Diagram

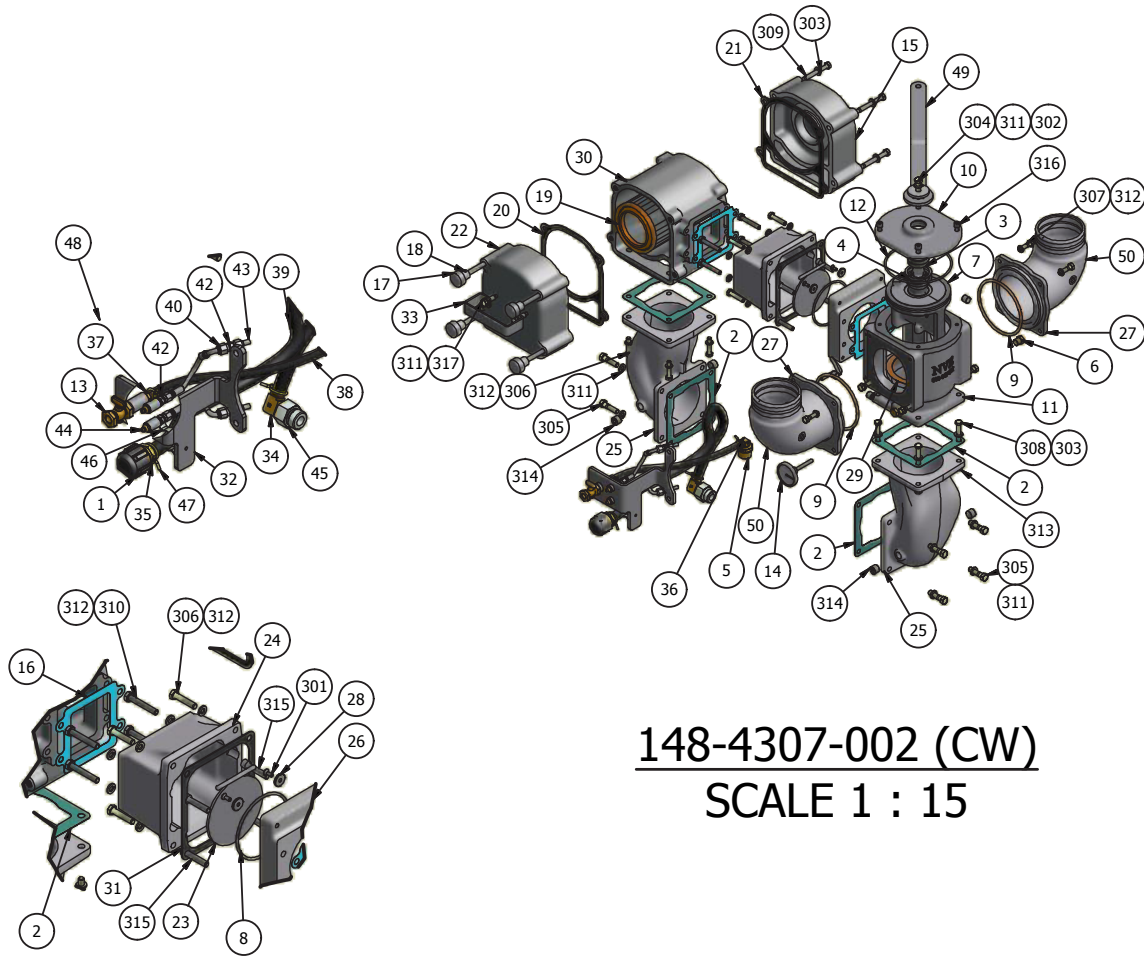

148-4307-002 (CW)
SCALE 1 : 15

4307 Manifold | Parts List

ITEM	QTY	PART NUMBER	DESCRIPTION
2	4	120-039-506	GASKET EXHAUST FLANGE
8	1	120-064-003	O-RING, 2-240 VITON
9	2	120-064-012	O-RING, 2-350 VITON
12	1	120-068	O-RING, 2-252 VITON
14	1	120-220	THERMOMETER, 50-400 DEG, 2" FACE
16	2	120-311	GASKET, FILTER HOUSING
17	4	120-312	KNOB, 3/8"-16 UNC
19	1	120-314	FILTER ELEMENT, INLET
20	1	120-315	GASKET, FILTER COVER
23		150-041-007	CHECK VALVE FLAPPER, 4" SS
31	1	150-616-002	GASKET, 4" SQ INTAKE CHECK
49	1	412-060-005	HANDLE, 4307 OFFSET 4-WAY ADJ



4310 Manifold | Parts Diagram

Challenger Series

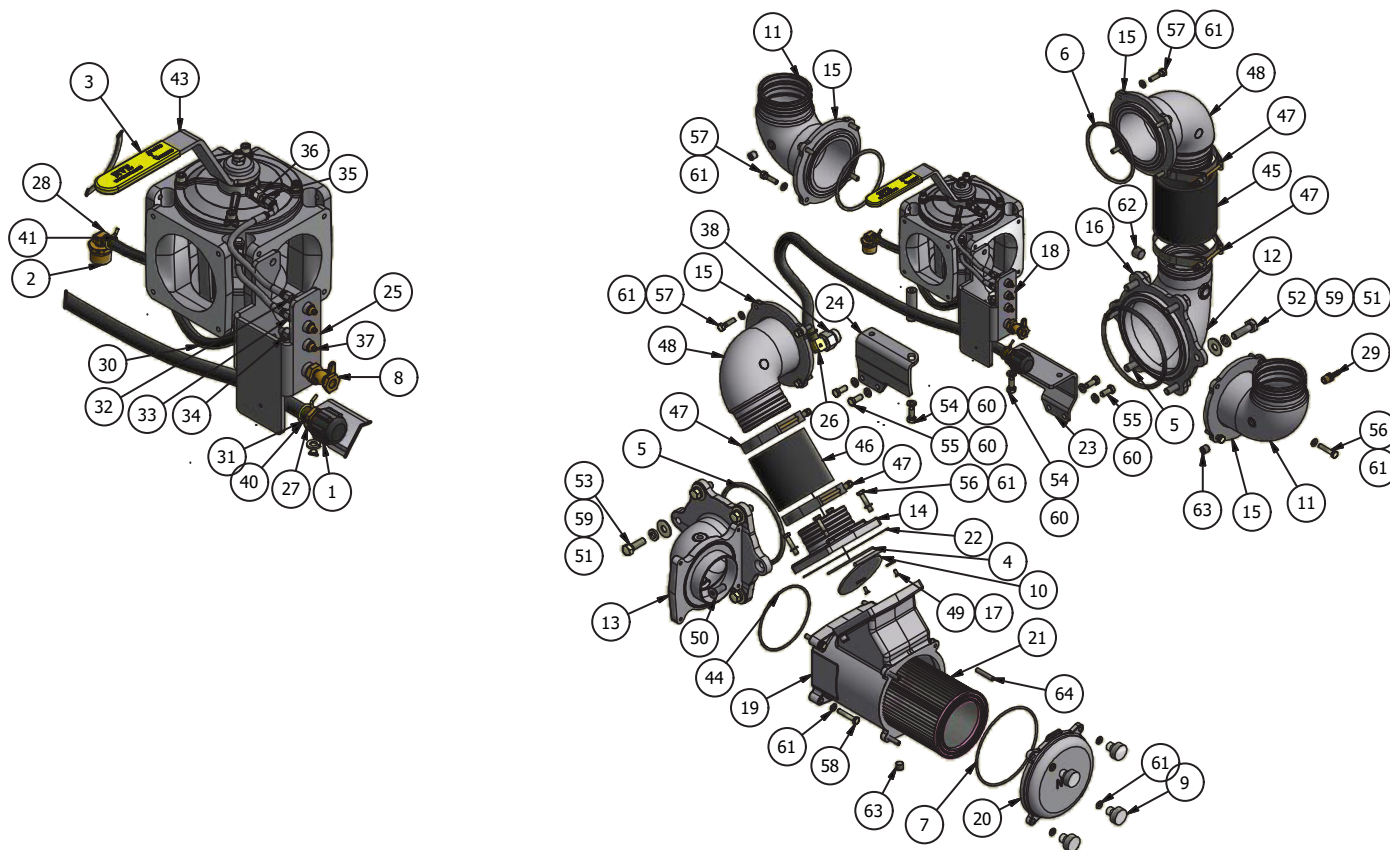

4310 Manifold | Parts List

ITEM	QTY	PART NUMBER	DESCRIPTION
4	1	120-064-003	O-RING, 2-240 VITON
5	2	120-064-011	O-RING, 2-438 VITON
6	4	120-064-012	O-RING, 2-350 VITON
7	1	120-064-013	O-RING, 2-259 VITON
9	4	120-312-002	KNOB, 5/16-18UNC
10	1	150-041-007	CHECK VALVE FLAPPER, 4 IN SS
21	1	150-314-002	FILTER, STAINLESS 4310
22	1	150-616-001	GASKET, 4" SQ INTAKE CHECK
43	1	412-060-009	HANDLE 4310 ENCLOSED
44	1	412-102-251	O-RING, 2-251, FPM

43 Series Components & Accessories

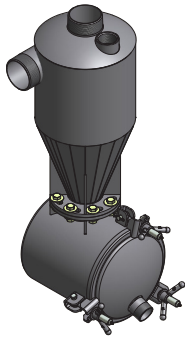

PRODUCT DESCRIPTION	PART NUMBER	WEIGHT	MSRP
Grit Ridder 600 - for 4307 blower	222-600-2	154 lbs	\$990.00
<ul style="list-style-type: none"> - Cyclonic action removes grit and debris from airflow. - Flanged center for optimum adjustability - 4" NPT inlet and outlet - Approximate Dimensions: L 18.5" x W 13" x H 45" 			

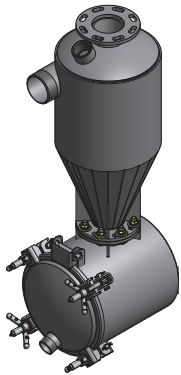

PRODUCT DESCRIPTION	PART NUMBER	WEIGHT	MSRP
Grit Ridder 900 - for 4310 blower	222-900-1	240 lbs	\$1,027.94
<ul style="list-style-type: none"> - Cyclonic action removes grit and debris from airflow. - Flanged center for optimum adjustability - 4" NPT inlet with 4" ANSI flange outlet - Approximate Dimensions: L 21" x W 15" x H 51" 			

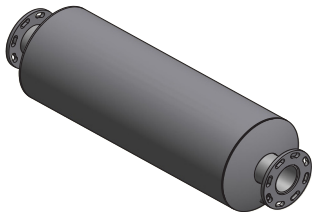

PRODUCT DESCRIPTION	PART NUMBER	WEIGHT	MSRP
Round Silencer	224-4310-03	194 lbs	\$1,575.00
<ul style="list-style-type: none"> - 4" ANSI flanged fittings - Approximate Dimensions: L 48.5" x W 14.25" x H 48.5" 			

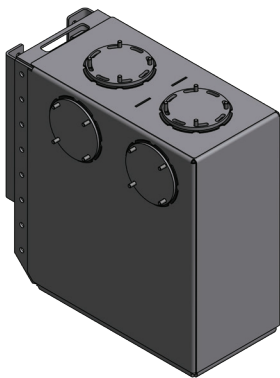

PRODUCT DESCRIPTION	PART NUMBER	WEIGHT	MSRP
Ultra Silencer	224-360-002	243 lbs	\$1,699.50
<ul style="list-style-type: none"> - Quiet operation - Stainless steel construction - Universal design with multiple porting options - Top and bottom flanged mounting options - Designed to work with the 4307 and 4310 - Approximate Dimensions: L 27" x W 12" x H 23" 			

43 Series Components & Accessories

Challenger Series

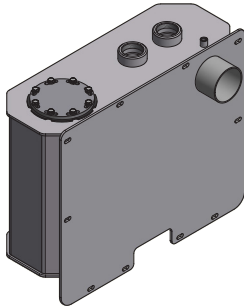

PRODUCT DESCRIPTION	PART NUMBER	WEIGHT	MSRP
Aluminum Moisture Trap - (for 4307 only)	218-001-003	83 lbs	\$1,055.75
Gauge 2.5" VAC/PRES Liquid Bot Conn 1/4" NPT	408-250-LF	0.45 lbs	\$15.01
Pressure Relief 2"	364-306-2	2.7 lbs	\$45.67
PDrain Valve Brass 1" IPS	288-100	----	\$19.06
- Approximate Dimensions: L 26.5" x W 11.25" x H 21.75"			

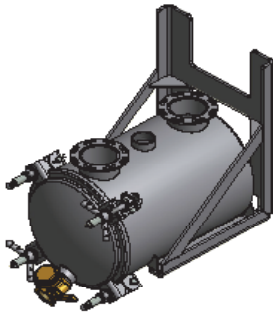

PRODUCT DESCRIPTION	PART NUMBER	WEIGHT	MSRP
Horizontal Moisture Trap	218-140-001	97 lbs	\$1,508.95
<ul style="list-style-type: none"> - Mounts to truck frame - Stainless steel construction - 4" TTMA flanged fittings - 2" drain valve - Lubenut wingnuts included - Designed to work with the 4307 and 4310 - Approximate Dimensions: L 30" x W 17" x H 25" 			

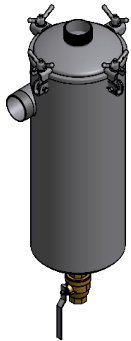

PRODUCT DESCRIPTION	PART NUMBER	WEIGHT	MSRP
14 Gal Moisture Trap Alu 4" NPT L 13" x W 13" x H 40.5"	216-140-4NPT-A	70 lbs	\$845.00
14 Gal Moisture Trap Carbon 4" NPT L 13" x W 13" x H 40.5"	216-140-4NPT-C	131 lbs	\$600.00
14 Gal Moisture Trap SS 4" NPT L 13" x W 13" x H 40.5"	216-140-4NPT-S	131 lbs	\$927.00
25 Gal Moisture Trap Alu 4" NPT L 18.5" x W 18.5" x H 48"	216-250-4NPT-A	93 lbs	\$1,079.34
25 Gal Moisture Trap Carbon 4" NPT L 18.5" x W 18.5" x H 48"	216-250-4NPT-C	171 lbs	\$812.00
25 Gal Moisture Trap SS 4" NPT L 18.5" x W 18.5" x H 48"	216-250-4NPT-S	171 lbs	\$1,766.45

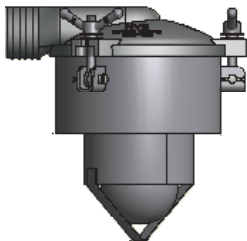

PRODUCT DESCRIPTION	PART NUMBER	WEIGHT	MSRP
PSO 12" X 6" CARBON BAE ALU LID 4" HB 10" CAGE	200-1206-4HB-10	50 lbs	\$490.00
PSO 12" X 6" ALU BASE ALU LID 4" HB 10" CAGE	204-1206-4HB-10	42 lbs	\$504.70
PSO 12" X 6" ALU BASE SS LID 4" NPT 10" CAGE	204-1206-4NPT-10	55 lbs	\$561.35
PSO 12" X 6" SS BASE ALU LID 4" HB 10" CAGE	208-1206-4HB-10	55 lbs	\$659.20

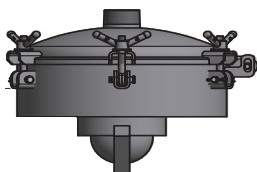

PRODUCT DESCRIPTION	PART NUMBER	WEIGHT	MSRP
PSO 20" X 6" CARBON BASE AND LID 4" NPT 10" CAGE	202-2006-4NPT-10	95 lbs	\$595.00

43 Series Components & Accessories



PRODUCT DESCRIPTION	PART NUMBER	WEIGHT	MSRP
Coupler Hub E20 1 3/8"	424-200-1375	7.25 lbs	\$47.38
Coupler Hub E20 1 1/2"	424-200-150	7.25 lbs	\$47.38
Coupler Flex Element E20	424-200-E20	4.15 lbs	\$123.60

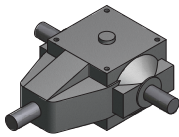

PRODUCT DESCRIPTION	PART NUMBER	WEIGHT	MSRP
4307 Gearbox 500 Series 1:2 Ratio with 1 3/8" shaft	422-500-1	27.75 lbs	\$631.39
4310 Gearbox 500 Series 1:2 Ratio spiral bevel gears with 1 3/8" shaft	422-500-2	28.30 lbs	\$792.07
4307/4310 Welded Gearbox	280-401-005	-----	\$139.00

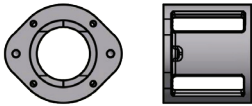

PRODUCT DESCRIPTION	PART NUMBER	WEIGHT	MSRP
Hydraulic Adapter - Aluminum SAE C-Face	150-466-002	17 lbs	\$185.40



PRODUCT DESCRIPTION	PART NUMBER	WEIGHT	MSRP
ISO 220 Synthetic Gear lube	150-220-LUBE	7.55 lbs	\$109.84

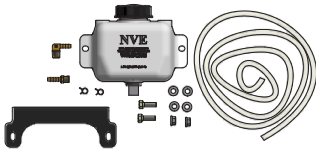

PRODUCT DESCRIPTION	PART NUMBER	WEIGHT	MSRP
Blower Package Flush Kit (Remote)	320-081-013	2 lbs	\$103.00
Diesel Tank Assy Hdpe 1QT	320-082-003Z	2 lbs	\$43.80
Cap Plastic Diesel Tank	320-083-002	0.10 lbs	\$7.34
Oil Line Blk 1/4" ID 30R7 per Ft.	320-407-003	0.4 lbs	\$1.67



PRODUCT DESCRIPTION	PART NUMBER	WEIGHT	MSRP
Flange 4" Adjustable Elbow	150-063-014	1.50 lbs	\$15.45
O-ring Viton for Elbow	120-064-012	.01 lbs	\$5.05
Elbow 4" 90 Degree Alum. Hose Barb x O-ring	803-063-001	2.00 lbs	\$40.17
Elbow 4" 90 Degree Alum. Hose Barb x Hose Barb	803-063-012	.69 lbs	\$40.17

43 Series Components & Accessories

Challenger Series

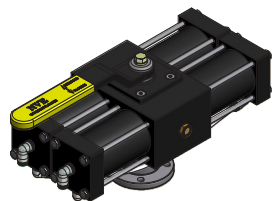

PRODUCT DESCRIPTION	PART NUMBER	WEIGHT	MSRP
3 Position Pneumatic Actuator for 4307 Blower	409-200-200	25 lbs	\$1,184.50
3 Position Pneumatic Actuator for 4310 Blower	409-200-100	25 lbs	\$1,184.50

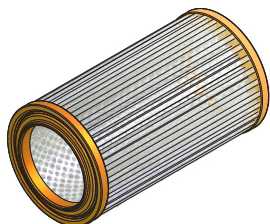

PRODUCT DESCRIPTION	PART NUMBER	WEIGHT	MSRP
4307 Inlet Filter	120-314	0.90 lbs	\$74.68
Gasket Cover Filtr 4-Way On 4307	120-315	0.04 lbs	\$29.38
4310 Inlet Filter	150-314-002	1.10 lbs	\$140.13
4307/4310 filter for remote 12" Final Filter	150-314-008	7 lbs	\$70.00

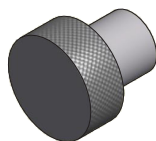

PRODUCT DESCRIPTION	PART NUMBER	WEIGHT	MSRP
4307 Knob - Filter Cover 3/8-16 UN	120-312	0.10 lbs	\$5.92
4310 Knob - Filter Cover 5/16-18 UN	120-312-002	0.10 lbs	\$4.64



PRODUCT DESCRIPTION	PART NUMBER	WEIGHT	MSRP
Thermometer Remote 200-450F 6' Bronze Lead -Blower Exhaust	408-200-002	2 lbs	\$140.65
Gauge 2.5" Vac/Pres Liq Back Conn 1/4 Npt	408-200-009	0.45 lbs	\$39.14



PRODUCT DESCRIPTION	PART NUMBER	WEIGHT	MSRP
Handle 4307 Enclosed	412-060-010	2 lbs	\$15.45
Handle 4310 Enclosed	412-060-009	2 lbs	\$15.45
Yellow Grip 1/4" Handle W/ Logo	120-060-002	0.05 lbs	\$2.01

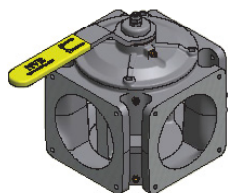

DESCRIPTION	PART NUMBER	WEIGHT	MSRP
Blower Assy No Flanges	410-004-002-NF	35.3 lbs	\$540.75

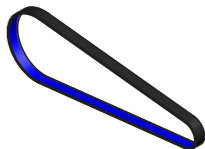

PRODUCT DESCRIPTION	PART NUMBER	WEIGHT	MSRP
Belt For Frame Mount Belt Drive 8MPCC-1760-36	430-200-028	3 lbs	\$334.75
Belt 36MM QTPCII 2000 for 147-4310-485 package	430-200-016	3 lbs	\$263.68
Belt 36MM QTPCII 2240 for 147-4310-486 package	430-200-032	3 lbs	\$352.00

Designed. Built. Supported.

Produced in the USA | Distributed World-Wide

Proudly Distributed By:

**ARMSTRONG
EQUIPMENT
INC.**

NVE
National Vacuum Equipment

Challenger Series
VACUUM PUMPS & BLOWERS