



SHURFLO® 5000 SERIES PUMPS

SHURFLO's new 5000 Series pumps include a unique diaphragm design whereby solid pistons are co-molded to the pump diaphragm, forming a leak proof molecular bond for ultimate durability and pumping efficiency. A newly designed electrostatically painted, fully sealed heavy duty motor powers the 5000 series.

The 5000's conical valves deliver consistent priming and performance, while an available internal bypass enables the pump to operate in varied demand conditions, without switch cycling.

The new 5000 series is uncompromising in every aspect of its design, construction, and performance, furthering SHURFLO's commitment to provide innovative, durable, high value products for our customers' applications.



BENEFITS

Heavy Duty Sealed Motor

Available Bypass

Runs Dry Without Damage

Self-Priming

CE compliant

Co-Molded Diaphragm

Compact 4 chamber design

Flow rates up to 5.3 GPM

Chemical resistant elastomers

SHURFLO® 5000 SERIES PUMPS

SPECIFICATIONS

Product	5050
Flow	5.3 GPM
Amps	17 [12VDC]
Voltage	12/24 VDC 120/230VAC
Pump Body	Polypropylene
Valves	Viton or EPDM
Diaphragm	Santoprene or Geolast
Shut-off	60 PSI
Pump Type	Standard or Bypass
Ports	1/2" NPSM-Male 1/2" NPT-Female
Standard Features	Sealed/E-Coated Motor
	Thermal Overload
	Run Dry Self-Priming

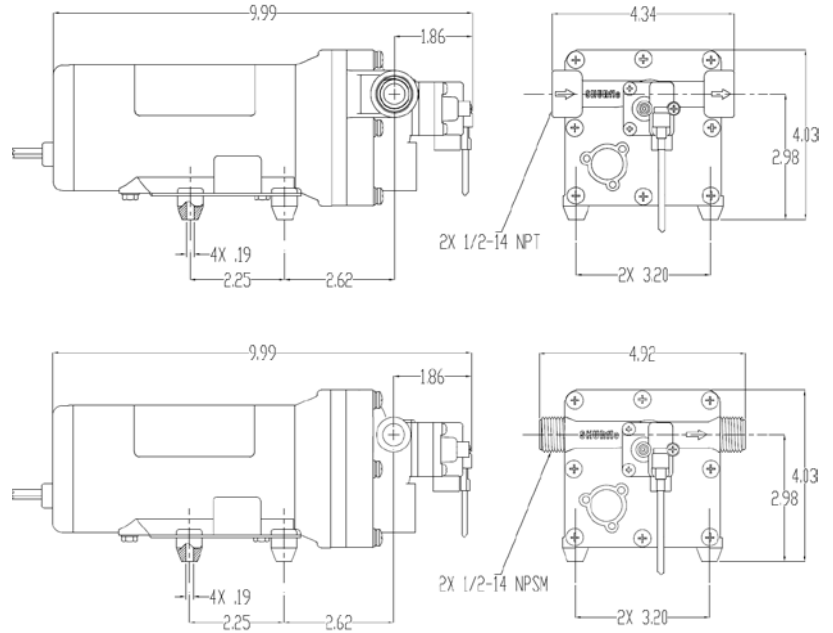

PERFORMANCE - Typical 12VDC Performance

PARTS & SERVICE KITS – 5050-1311-D011 (Non-Bypass)

5050-1311-D011 (Non-Bypass)

PRESSURE		FLOW		CURRENT
BAR	PSI	GPM	LPM	AMPS
0	0	5.3	20	6.5
0.7	10	4.7	17.7	9.0
1.4	20	4.3	16.2	11.8
2.1	30	4.1	15.5	12.4
2.8	40	3.8	14.3	14.0
3.4	50	3.6	13.6	15.4
4.1	60	3.4	12.8	17.0

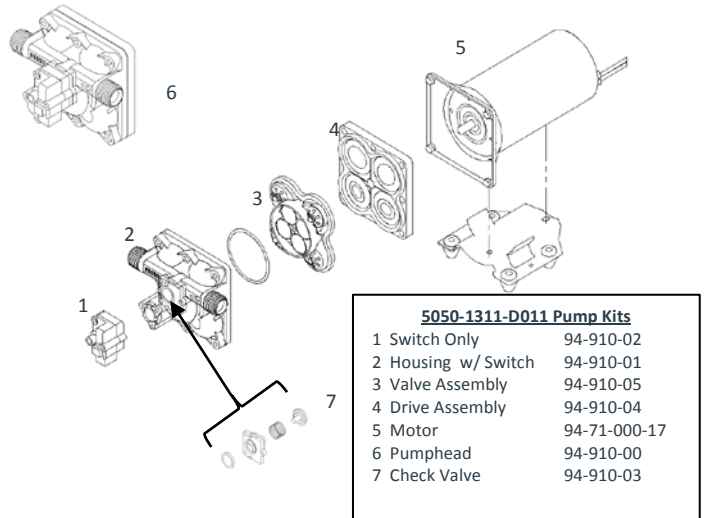

WATER PURIFICATION

3545 Harbor Gateway South, Suite 103, Costa Mesa, CA 92626, (800) 854-3218 www.Pentair.com

All Pentair trademarks and logos are owned by Pentair, Inc. All other brand or product names are trademarks or registered marks of their respective owners. Because we are continuously improving our products and services, Pentair reserves the right to change specifications without prior notice.

Pentair is an equal opportunity employer.

MS-040-XXX 02/13 ©Pentair, Inc. All Rights Reserved