

# 2, 3 & 4" HORIZONTAL OIL CATCH MUFFLERS

CAPTURES PUMP OIL AND QUIETS PUMP NOISE!

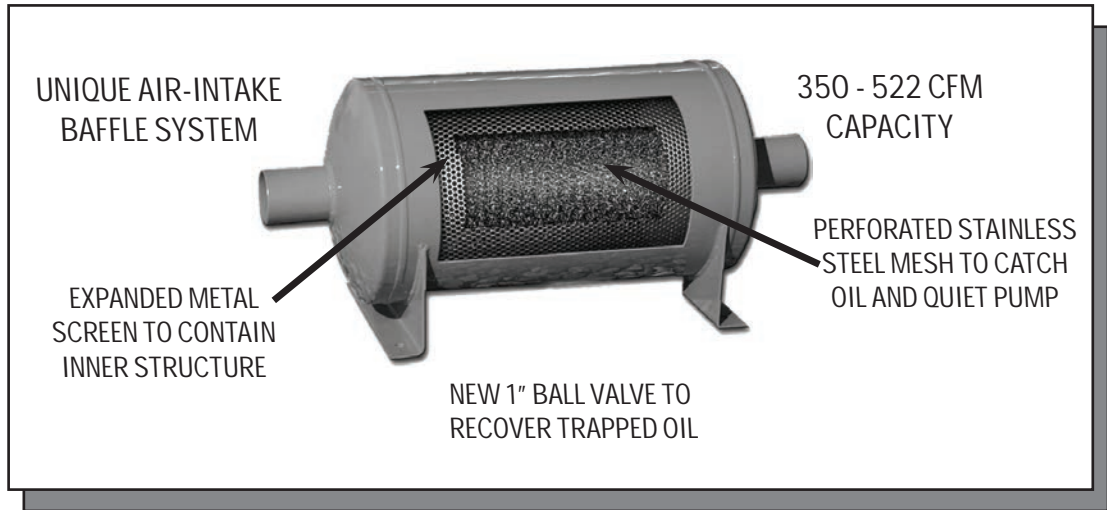

HORIZONTAL MUFFLERS

PART#	DESCRIPTION	L x W x H	WEIGHT
1001-0002	2" HORIZONTAL OIL CATCH MUFFLER (350 CFM)	25.5 x 14 x 16	56LBS
1001-0003	2" HORIZONTAL OIL CATCH MUFFLER W/THREADS (350 CFM)	25.5 x 14 x 16	56LBS
1001-0000	3" HORIZONTAL OIL CATCH MUFFLER (350 CFM)	25.5 x 14 x 16	56LBS
1001-0013	3" HORIZONTAL OIL CATCH MUFFLER W/THREADS (350 CFM)	25.5 x 14 x 16	56LBS
1001-0500	4" HI-CAPACITY HORIZONTAL MUFFLER (522 CFM)	32 x 16 x 18	90LBS
1001-0501	4" HI-CAPACITY HORIZONTAL MUFFLER W/THREADS (522 CFM)	32 x 16 x 18	90LBS

#	PART#	DESCRIPTION
REPLACEMENT PARTS		
1	1037-0001	1" BRASS BALL VALVE
2	1001-0020	1" CLOSE NIPPLE

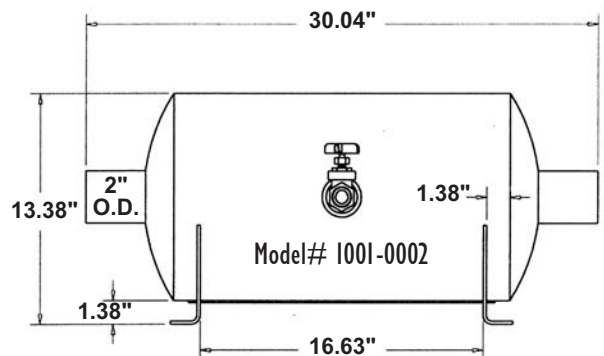
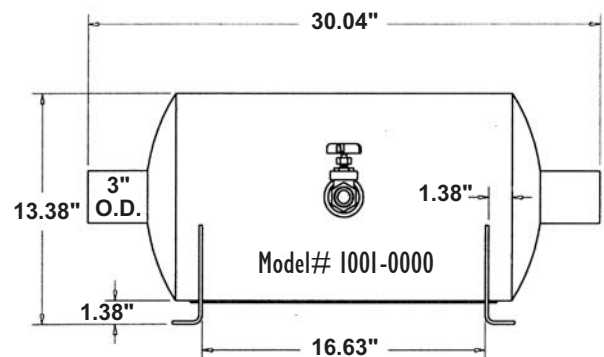
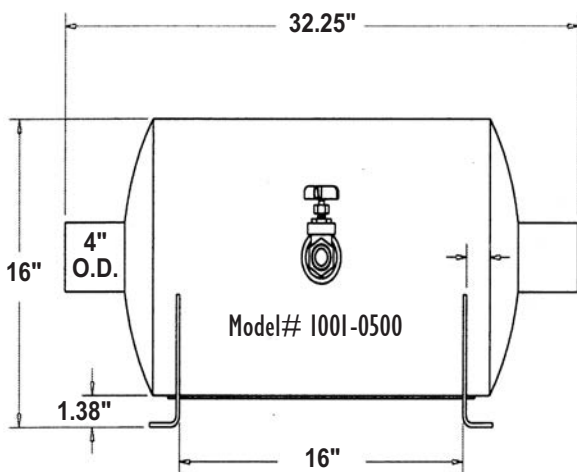

SEE LIST OF OPTIONAL FITTINGS ON PAGE 70.