

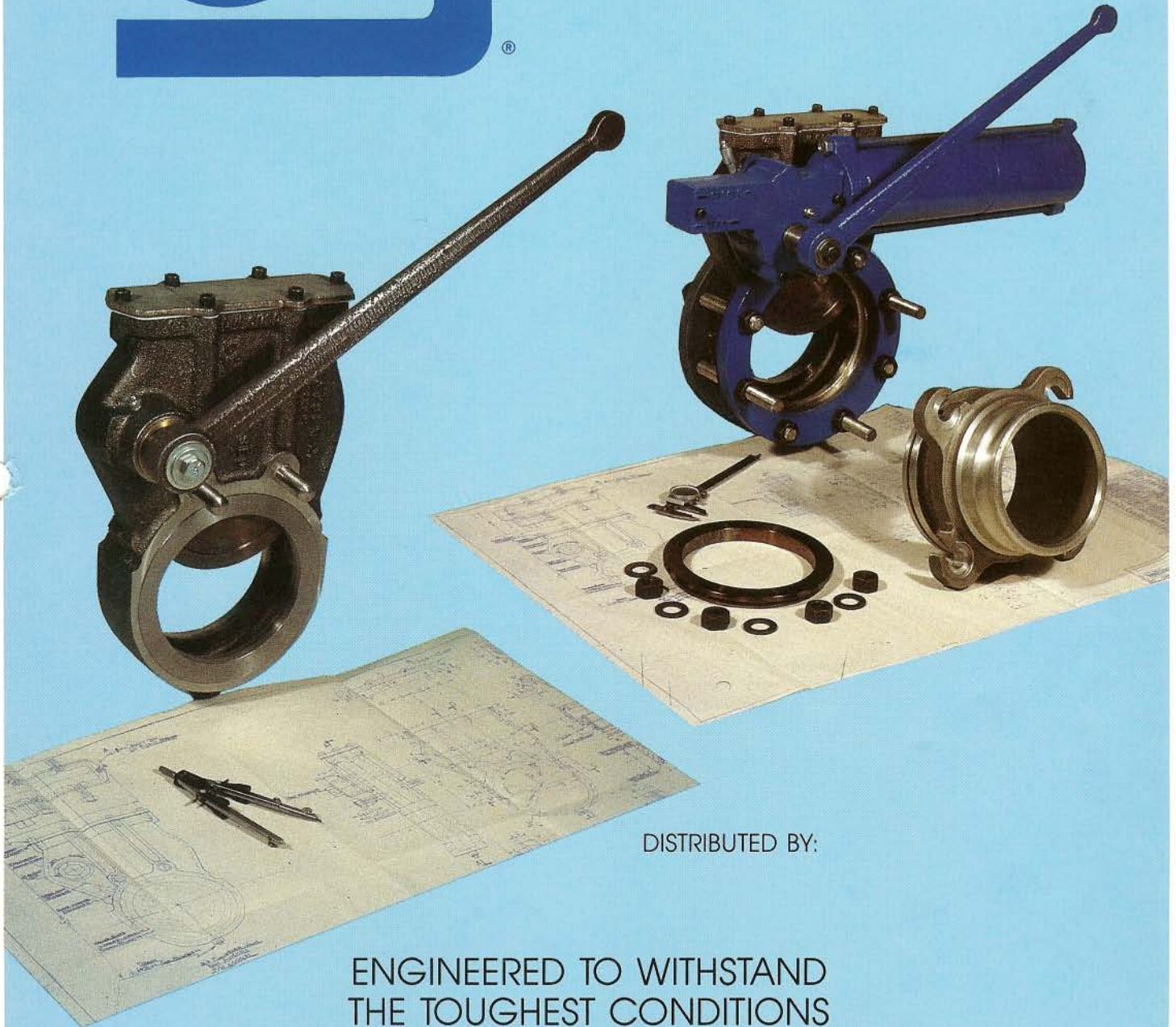

LIGHT WEIGHT GATE VALVES



DISTRIBUTED BY:

ENGINEERED TO WITHSTAND
THE TOUGHEST CONDITIONS
IN THE PRESSURE/VACUUM
TANK TRUCK INDUSTRY

U.S. Patent #4,640,302

CFI Valve
Specialties

631 Camelia Street
(415) 525-1700

Berkeley, CA 94710
FAX (415) 525-5952





* Valve Seats, Discs & Spring may be replaced in the field without removing the valve from the tank

* 100% full opening

* Top side flush out

* This is the basic valve without enhancements added.

* Manually operated open & close.

* To clean valve, remove top cover plate and flush with light kerosene or like solvent.

Available in:

4" Cast Steel=34 lbs.

6" Cast Steel=54 lbs.

4" Stainless Steel=33 lbs.

6" Stainless Steel=53 lbs.

Dimensions:

14 1/2" x 6 7/8"

16 1/2" x 10 3/4"

14 1/2" x 6 7/8"

16 1/2" x 10 3/4"

6" Valve

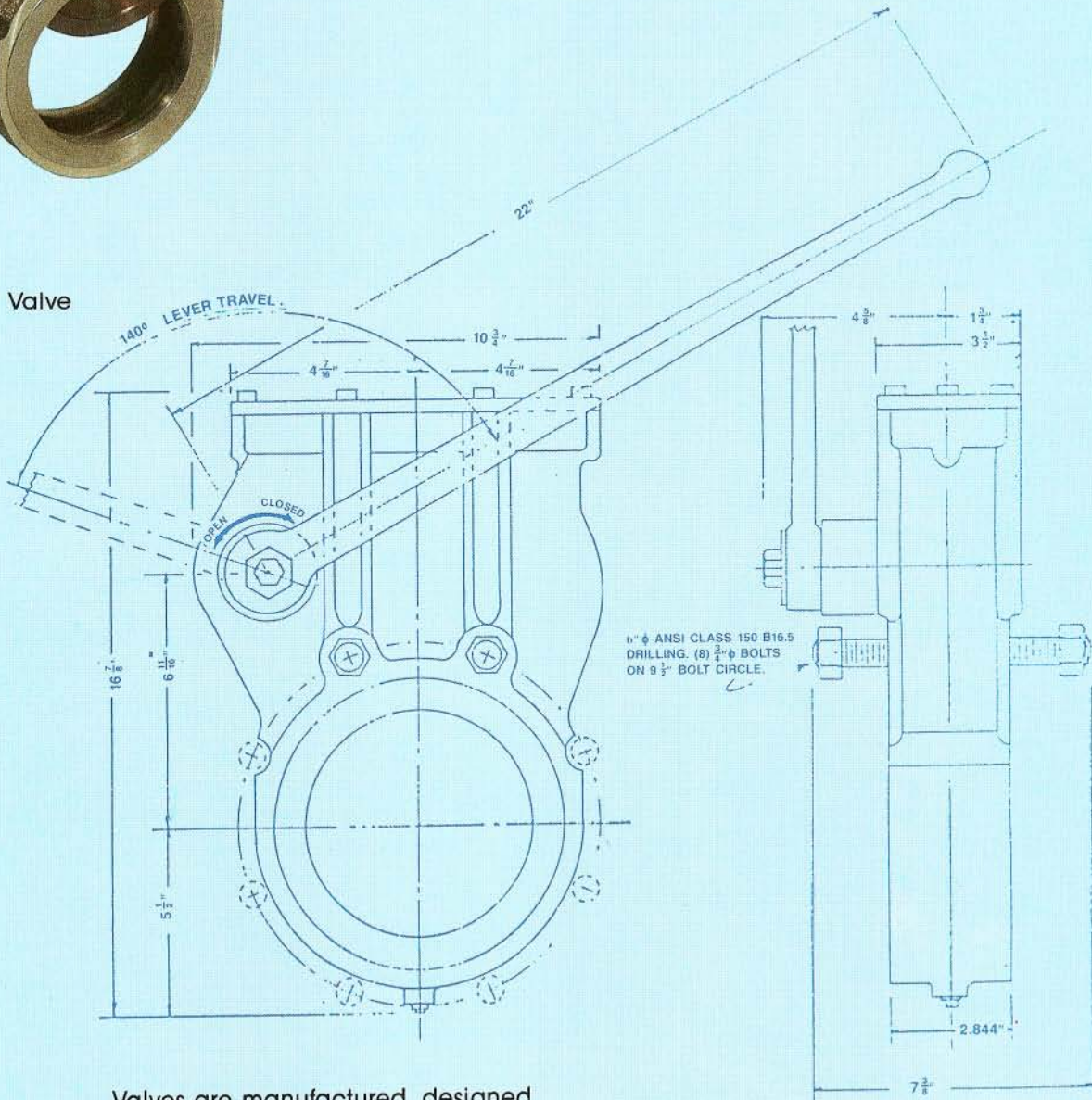

Valves are manufactured, designed & engineered in the U.S.A.



4" Valve

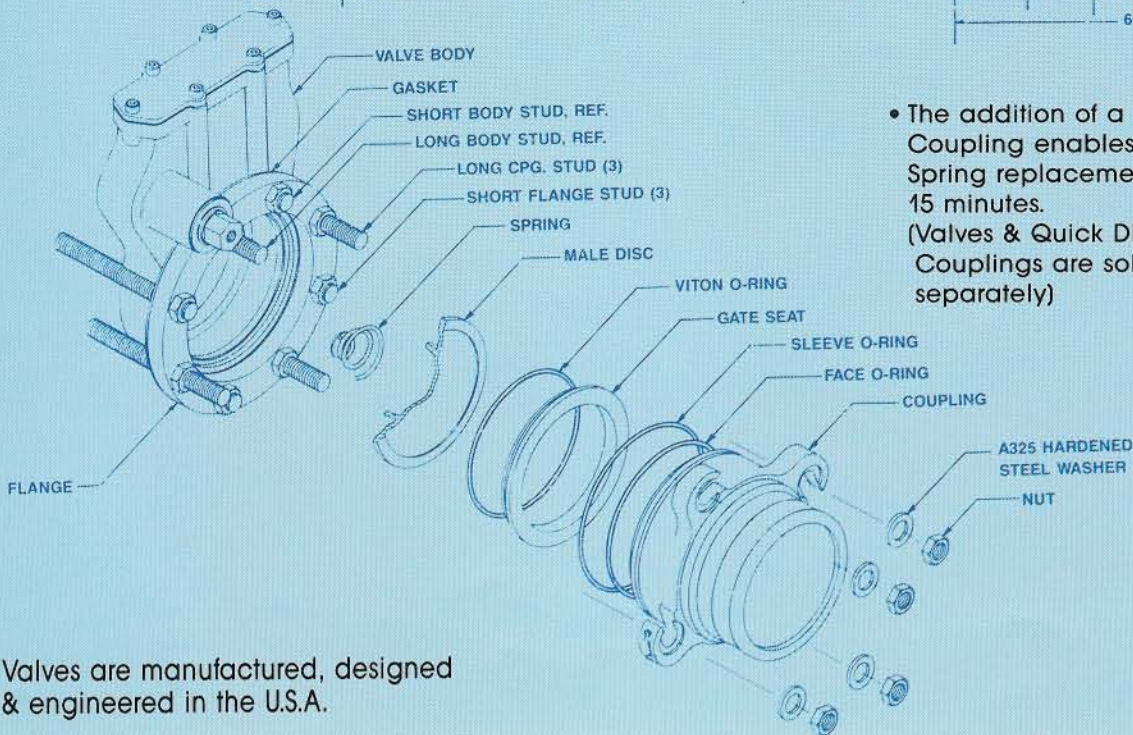
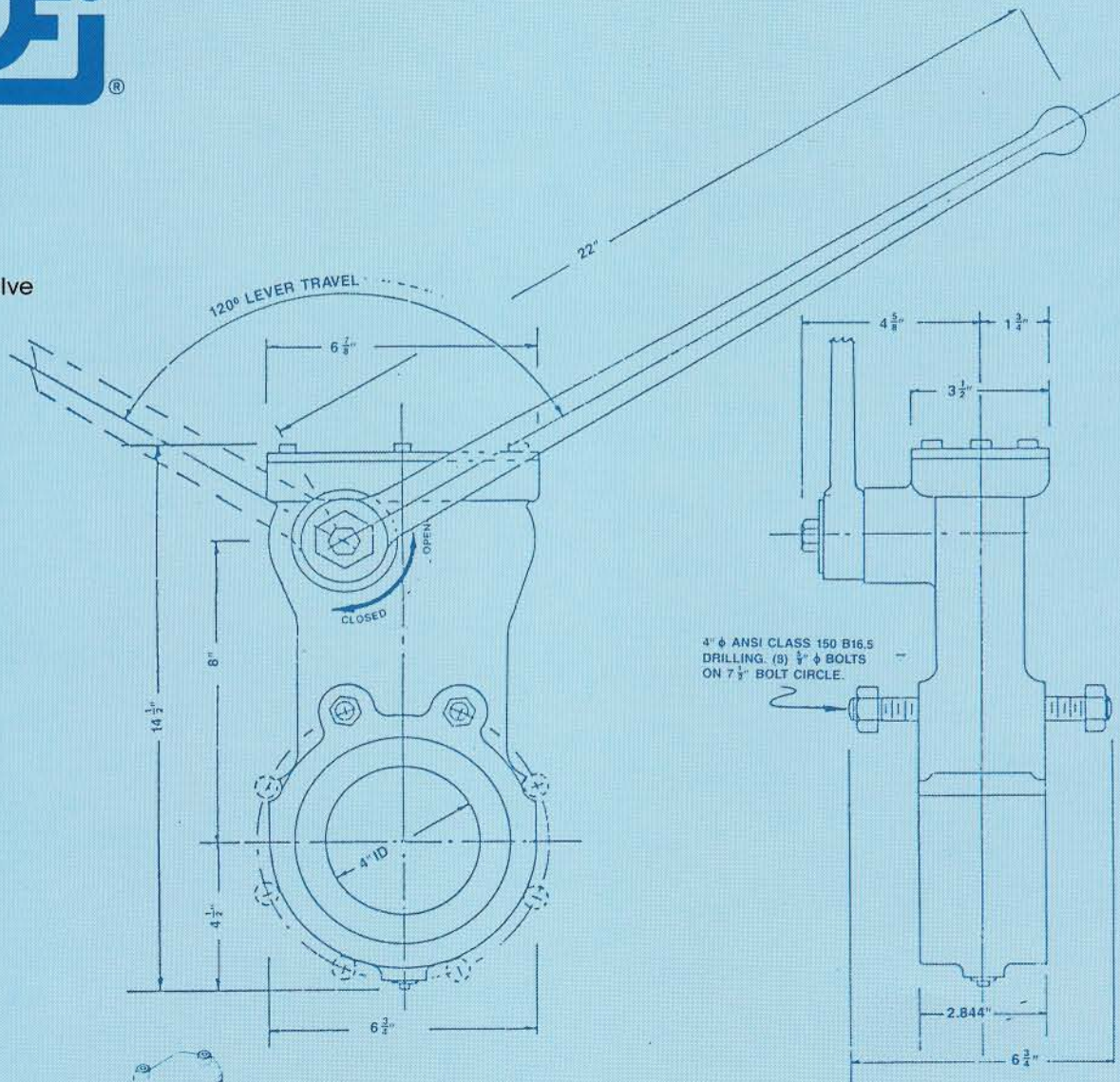

- The addition of a Quick Disconnect Coupling enables Seats, Discs & Spring replacement in approximately 15 minutes. (Valves & Quick Disconnect Couplings are sold separately)

Valves are manufactured, designed & engineered in the U.S.A.



LIGHT WEIGHT GATE VALVE
with
ACTUATOR and QUICK DISCONNECT COUPLING

Available in:

Manual Self-Closing or
Hydraulic Self-Closing Actuator

Hydraulic Pump Required in
Either Case

- * Hydraulic Opening
- * Spring Loaded Closure
- * 1500 PSI to Open
- * Emergency Closure can be activated when necessary
- * Remote Closure by relieving Hydraulic Pressure
- * Manual Self-Closing Actuator can be Pressure Loaded to the Self-Closing position and allows manual operation with hand lever

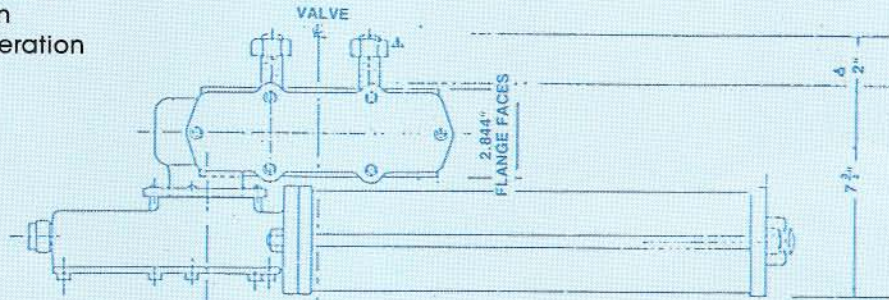

6" Valve
Equipped with
Actuator

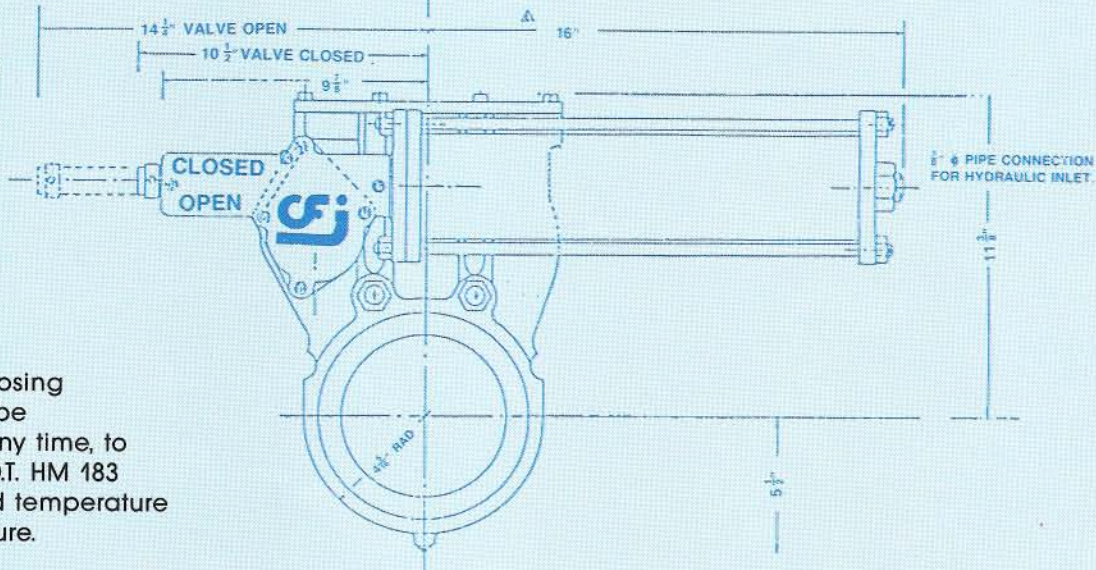

- * External self-closing actuator can be adapted, at any time, to conform to D.O.T. HM 183 for remote and temperature actuated closure.



4" Valve
Equipped with
Actuator

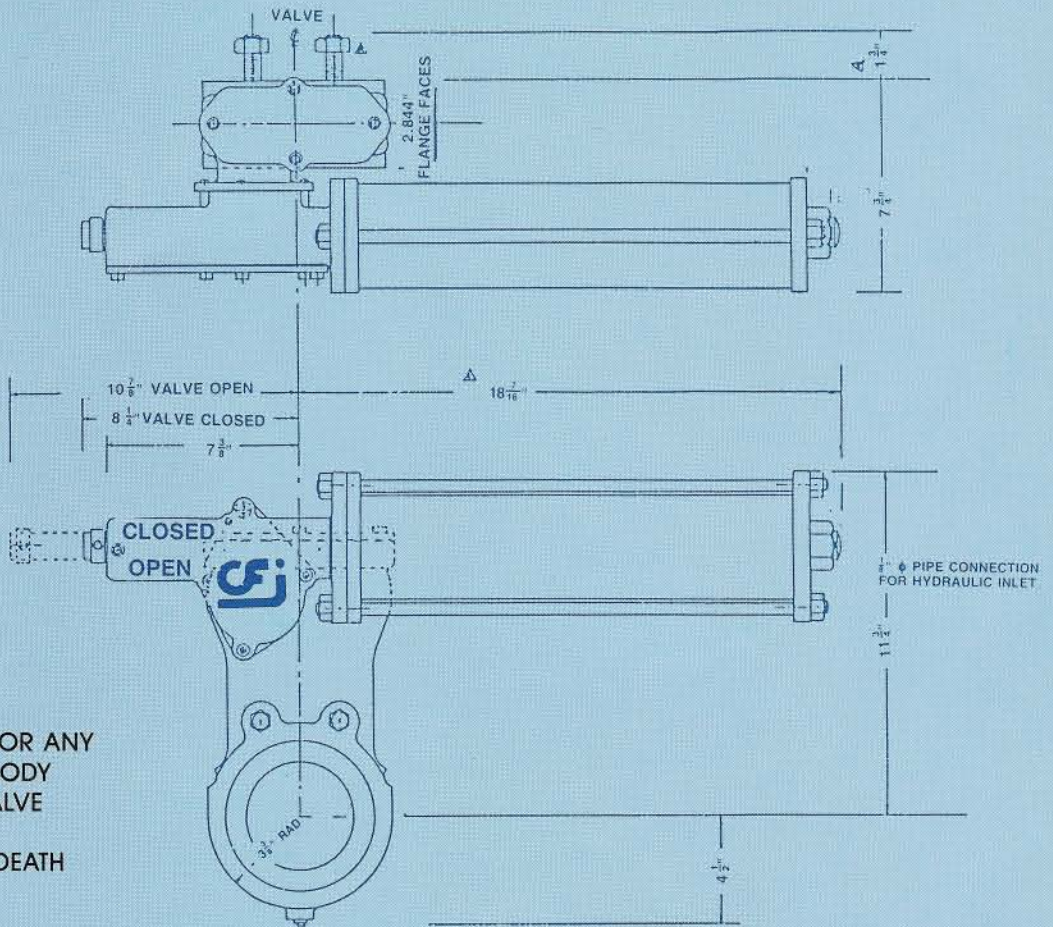

EXTREME DANGER:

NEVER PLACE HANDS OR ANY
OTHER PARTS OF THE BODY
OR OBJECTS IN THE VALVE
OPENING. INJURY,
DISMEMBERMENT OR DEATH
MAY OCCUR.

Hydraulic Pump

