



PR Series Manual



Introduction

Please follow carefully the instructions of the manual for a correct installation, use and maintenance of your vacuum pump.

Important issues

Starting

Start off the pump slowly. Forced engagement may cause damage to the transmission.

Stopping

Disengage the pump transmission before stopping the drive. Do not stop the engine while the pump is operating.

Operating

- Do not block or alter the relief valves adjustment, in order to avoid damage or explosion.
- Do not splash the pump with water or other liquid while the pump is running.
- Keep the rotation speed within the given limits.

In case of any obstruction along the suction line stop the pump and remove the cause.

Do not adjust the flow by means of gate valves or relief valves which are not suitable for such purpose. The flow and the vacuum rate can be adjusted changing the speed of the pump.

The pump must be installed according to local safety requirements. In the countries of the common market according to standard n° 89/392 CEE.

Weekly maintenance

Suction filter

The pump must be stopped while cleaning the suction filter. The filter can be cleaned using detergent liquid, diesel fuel and a high pressure jet of air.

Safety relief valve

Both pressure or vacuum relief valves must be cleaned and checked periodically

Non-return valve

In case of vibrations the check valve must be replaced.

We suggest that expert personnel must check the pump once a year. Wear parts must be replaced within three years.

Contents

| | | | |
|---------|--|-----|-----------------------------------|
| 1 | Dimensions and performances | 4.2 | Performance control |
| 2 | Installation | 4.3 | Temperature of the cooling liquid |
| 2.1 | Initial check | 4.4 | Intake of liquids |
| 2.2 | Protection of the inlet port | 4.5 | Checking of the wear of the vanes |
| 2.3 | Protection against intake of liquids | 4.6 | Replacement of the vanes |
| 2.4 | Non-return check valve | 4.7 | Cleaning of filter |
| 2.5 | 4 way valve | 4.8 | Preliminary maintenance |
| 2.6 | Exhauster/Oil separator | 4.9 | Trouble shooting |
| 2.7 | Cooling of the pump | 5 | Spare parts list |
| 2.8 | Pressure relief valve | | |
| 2.9 | Vacuum relief valve | | |
| 3 | Running of the pump | | |
| 3.1-3.6 | Check of the start-off and running of the pump | | |
| 4 | Maintenance of the vacuum pump | | |
| 4.1 | Lubrication | | |

1 Dimensions and performances

Vacuum pump/compressor. Series PR.

Lubricated, sliding vanes pump.

Application

- Sludge and slurry suction vehicles . Dusty materials with suitable suction filter.
- Vacuum plants.
- Pneumatic transport installations.

Drive

- By vehicle engine with mechanical transmission.
- With auxiliary engine, electric motor, etc.
- Hydrostatic drive.

NOTE The pumps are delivered for right or left rotation upon request.

Cooling and lubrication

Cooling is obtained by forced circulation with external pump.

Automatic oil lubrication of the moving parts with a piston pump driven by the rotor. High capacity oil tank with level sightglass.

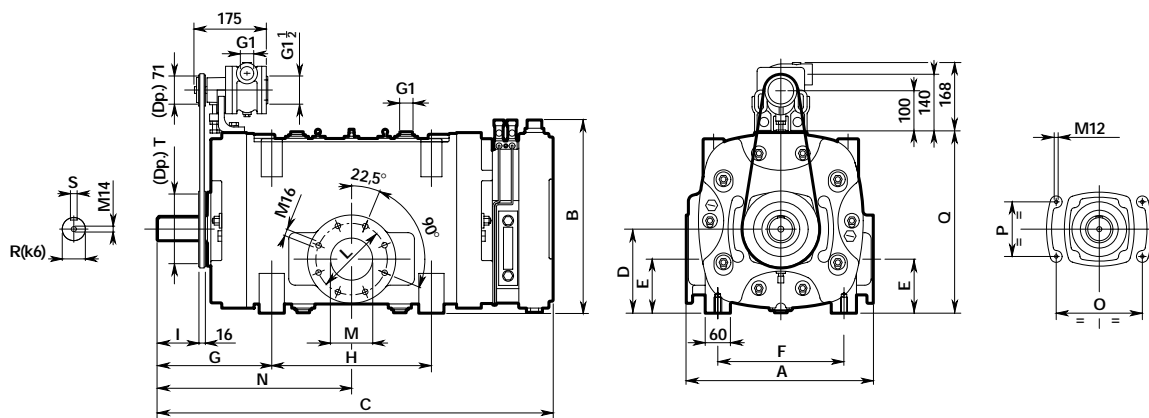

Dimensions mm

| Mod. | A | B | C | D | E | F | G | H | I | L | M | N | O | P | Q | R | S | T |
|-------|-----|-----|------|-----|-----|-----|-----|-----|----|-----|-----|-----|-----|-----|-----|----|----|-----|
| PR150 | 400 | 435 | 866 | 187 | 120 | 280 | 256 | 320 | 80 | 150 | 90 | 416 | 185 | 110 | 402 | 45 | 14 | 150 |
| PR200 | 445 | 460 | 943 | 200 | 128 | 300 | 273 | 380 | 99 | 170 | 100 | 463 | 205 | 130 | 430 | 55 | 16 | 180 |
| PR250 | 445 | 460 | 1123 | 200 | 144 | 300 | 283 | 540 | 99 | 200 | 130 | 553 | 205 | 130 | 430 | 55 | 16 | 180 |

Performances

| Mod. | PR150 | PR200 | PR250 | |
|--|-------------------|-------|--------|--------|
| Suggested speed | min ⁻¹ | 1200 | 1200 | 1100 |
| Air flow free air | m ³ /h | 900 | 1250 | 1550 |
| Air flow at 400 mbar/60% vacuum | m ³ /h | 860 | 1210 | 1470 |
| Maximum vacuum | % | 95 | 95 | 95 |
| Max vacuum continuous duty | % | 80 | 80 | 80 |
| Power required at 0,5 bar rel. (1,5 abs.) | kW | 28 | 39 | 48 |
| Max operating rel. pressure (abs.) | bar | 1 (2) | 1 (2) | 1 (2) |
| Sound pressure level at 7 m and 60% vacuum | dBA | 75 | 74 | 78 |
| Weight | kg | 345 | 445 | 530 |
| Oil consumption | g/h | 210 | 250 | 330 |
| Oil tank capacity | l | 11 | 13 | 13 |
| Mass moment of inertia | kgm ² | 0,57 | 0,96 | 1,30 |
| Heat to be dissipated | kcal/h | 8.000 | 11.000 | 12.000 |
| Circulating pump flow rate | l/min | 50 | 70 | 80 |
| Circulating pump speed | min ⁻¹ | 2.600 | 3.000 | 2.800 |

Lubrification

| Manufacturer | AGIP | ESSO | SHELL | ELF | MOBIL | BP |
|--------------|--------------------------|--|------------------|----------------------|-----------------|-----------------|
| Summer | ISO VG 150 Radula 150 | Nurray 150 | Vitrea 150 | Movixa 150 | Rubrex 900 | Energol CS 150 |
| Winter | SAE 10W SAE 20W | Diesel Sigma S 10W20 Essolube HDX 20W20 | Rimula X Oil 10W | Tractorelf ST3 20W20 | Delvac 1310 10W | Vanellus C3 20W |

Flow rate/pressure

Power/pressure

PR 150

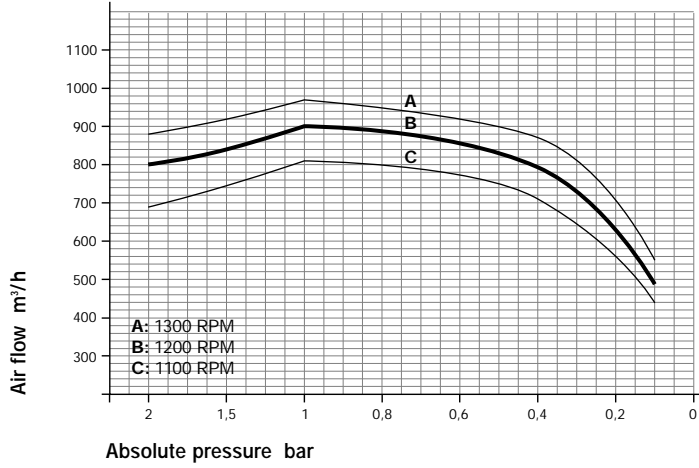

PR 150

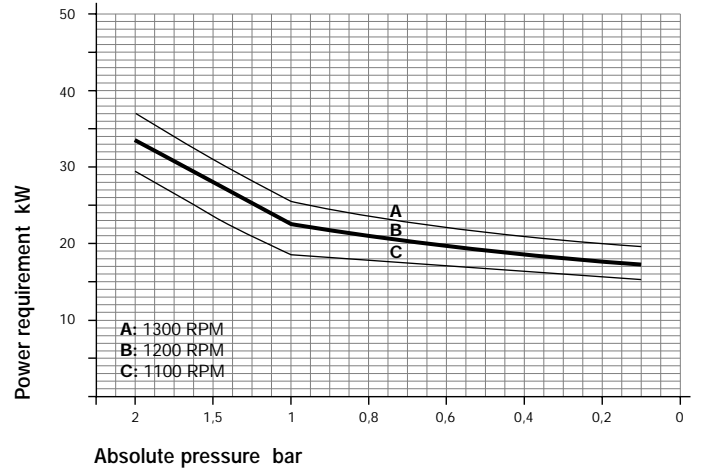

PR 200

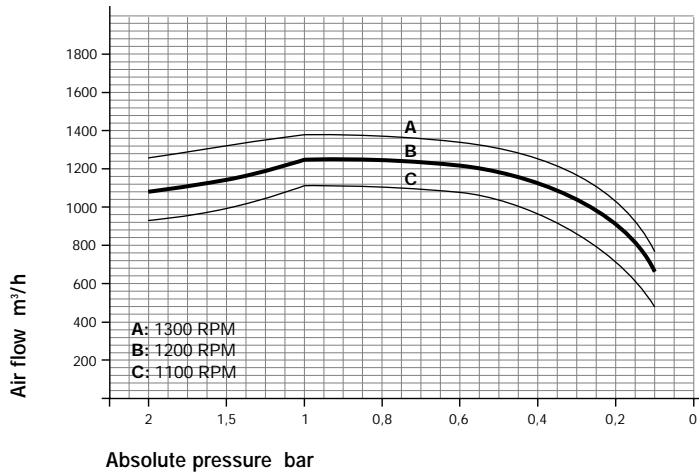

PR 200

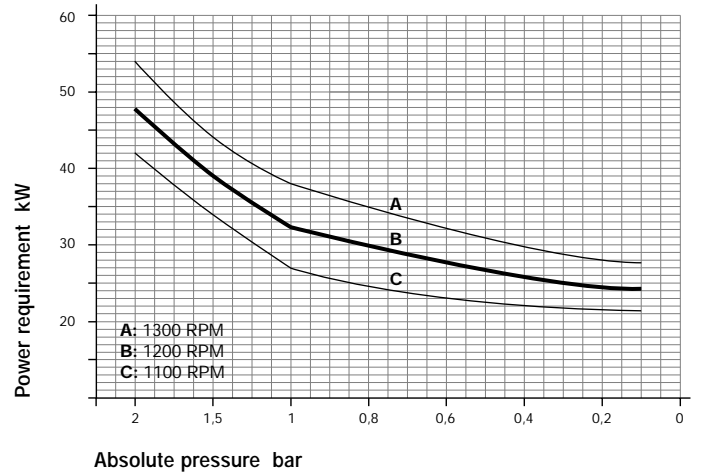

PR 250

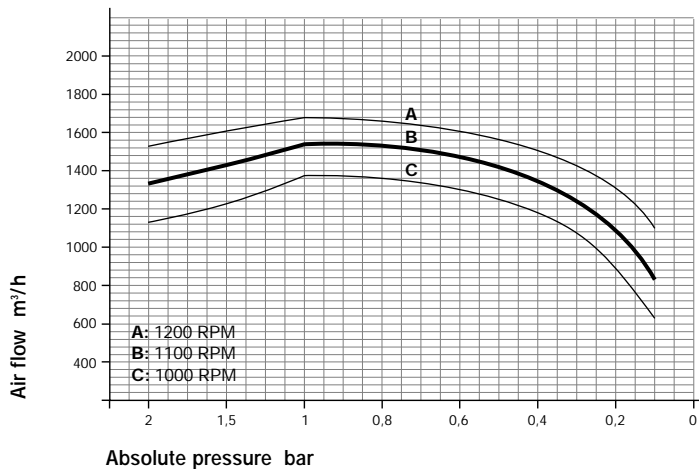

PR 250

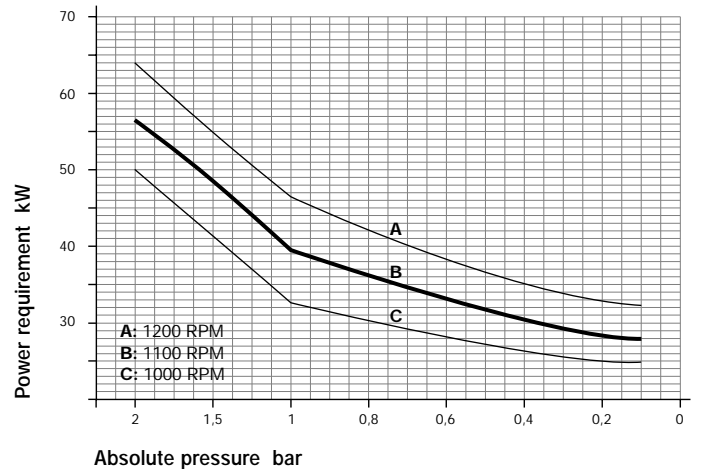

Sound pressure level

PR 150

fig. 1

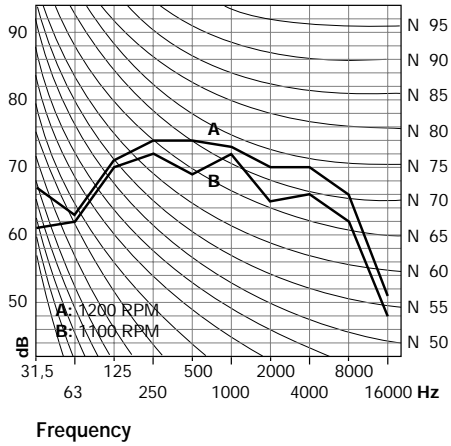

PR 200

fig. 2

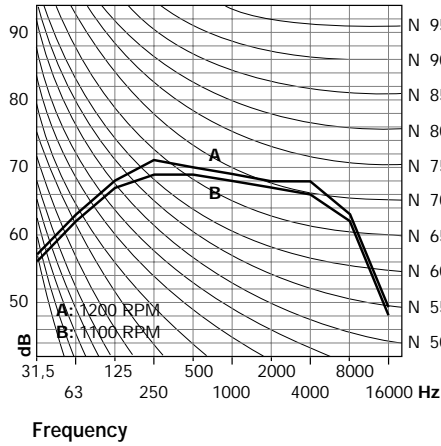

PR 250

fig. 3

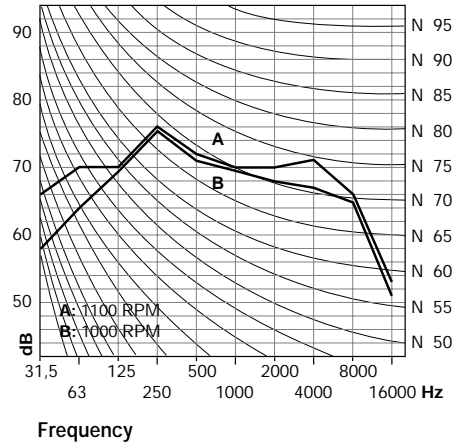

■ The diagrams (fig. 1-2-3) show the sound analysis of PR vacuum pumps measured at 456 mm Hg (60% vacuum) at 7 m distance for different rotation speed. In such conditions the reference value is:

| | | |
|-------|--------------|--------|
| PR150 | 1.100 r.p.m. | 72 dBA |
| | 1.200 r.p.m. | 75 dBA |
| PR200 | 1.100 r.p.m. | 72 dBA |
| | 1.200 r.p.m. | 74 dBA |
| PR250 | 1.000 r.p.m. | 76 dBA |
| | 1.100 r.p.m. | 78 dBA |

To have the sound level for different distances and/or vacuum rates add the **correction factor** from fig. 4 to the reference value.

Example: PR150 a 1.100 g/min., 30% vacuum and 4 m: 72+6=78 m.

Correction factor

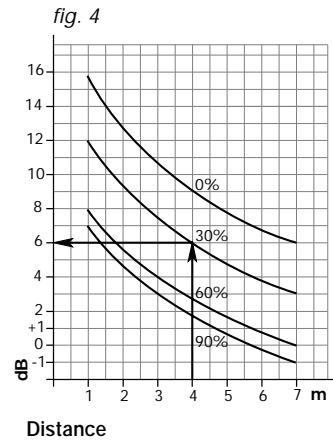

Water recycling pump

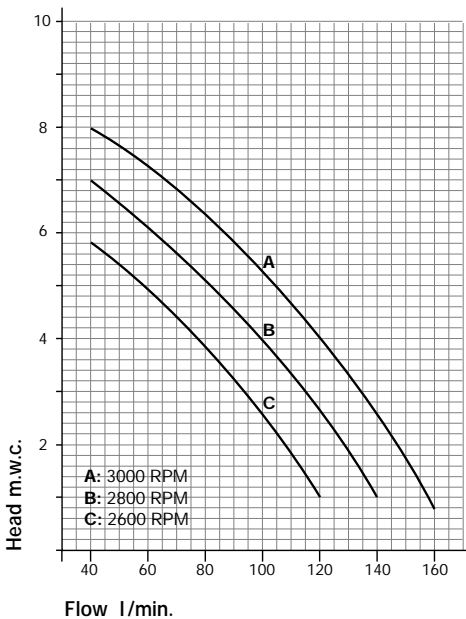

Evacuation times

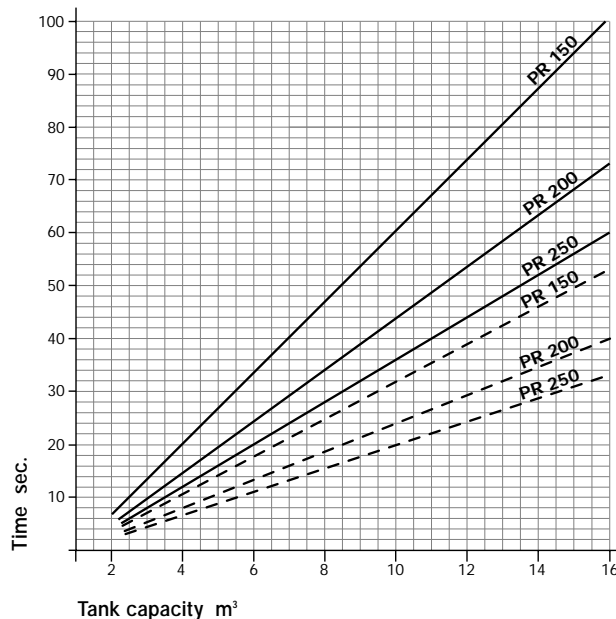

■ The diagram gives the evacuation time for a tank of a stated capacity. The actual time is affected by the air tightness of the whole vacuum system.

2 Installation

NOTE *The following indications are valid for mobile installation on trucks and anyhow must be followed also for stationery applications.*

2.1 Initial check

Upon receiving the pump, check if it has been damaged during the delivery.

Positioning

The pump must be placed on the vehicle so that it can be easily reached for maintenance.

Drive and alignment

The pump can be driven either mechanically by cardan shaft, belts and pulley or by hydraulic motor.

The cardan shaft must be mounted so that it does not create axial thrust and a flexible joint must be used; the inclination of the shaft must not exceed 15° (see fig. 3).

When using the belts and pulley, the pulley can be mounted directly on the rotor shaft (see fig. 2).

The alignment between the pulley of the pump and the driving pulley must be thoroughly checked.

The V-belts tension must be normal, which means that the belts must flex for about 2 cm. under the thumb pressure (see fig. 3).

With the hydraulic transmission the motor must be mounted by means of a support and a flexible joint. (see fig. 1)

When mounting the pump on a vehicle, it must be fixed to the chassis by a suitable stand.

Check that the rotation is the same shown on the pump.

NOTE *Rotation speed must not exceed the suggested value (see page 4-5).*

The rubber pipelines of the vacuum line must be of oil and corrosion-resistant material.

Before connecting the pipeline be sure that the inside is clean. Draining taps must be placed on the lowest part of the suction connection in order to drain the condensation.

When first running the pump, or after a long period of inactivity, or after operating in a dusty environment the pump must be washed out by introducing about 2 litres of diesel fuel through the inlet port.

NOTE *This operation must last not more than 30". If necessary repeat such operation after 10'*

2.2 Protection of the inlet port

In order to avoid solid parts to enter the pump a filter with stainless steel mesh of 300 micron filtration capacity must be mounted on the suction line just in front of the inlet port in an accessible position. (see fig. 1-2 Pos. 5)

2.3 Protection against intake of liquids

In order to avoid the intake of liquids, the pump must be protected by a primary shutoff mounted on top of the tank and a secondary shutoff mounted along the suction line both with an overflowing device. The air passage must be at least equivalent to that of the suction line. (see fig. 1-2 Pos. 1-2)

2.4 Non-return check valve

A non-return check valve must be placed along the suction line in between the pump and the 4 way valve. Be sure that such valve opens according to the flow direction and that the air passage is at least equivalent to that of the suction pipeline. (see fig. 1-2 Pos. 4)

2.5 4 way valve

If the 4 way change-over valve is driven by a pneumatic cylinder, the stroke must be exactly adjusted, so that the valve cock stops at the exact position, at the end of the stroke. (see fig. 1-2 Pos. 3)

2.6 Exhauster/Oil separator

The noise made by the pump must be reduced by a silencer placed along the discharge line, as close as possible to the outlet of the pump. It must be adequate for the air flow of the vacuum pump. The oil used for lubricating the vacuum pump must be separated by means of a suitable oil separator (normally built in the exhauster). Such oil separator must be drained by means of a tap which has to be checked daily (see Pos. 7 - Fig. 1-2).

2.7 Cooling of the pump

The cooling system consists of a centrifugal recycling pump (see performances at pag. 4÷6) supplied together with the vacuum pump, of a heat exchanger c/w fans suitable for dissipating the heat generated by the system (see pag. 4) and of an expansion tank. The temperature of the cooling media must not exceed 60° C. The heat exchanger must be placed so that the air can stream freely.

The use of antifreeze glicole is suggested.

2.8 Pressure relief valve

A pressure relief valve capable of discharging the whole flow of air of the pump must be placed in between the tank and the vacuum pump.

The valve must be adjusted at a discharge pressure not more than 10% higher than the operating pressure of the vacuum pump and anyhow not higher than the operating pressure of the tank.

2.9 Vacuum relief valve

The vacuum relief valve has the function of keeping the operating vacuum rate below that designed as the maximum for the pump.

(The installation of such valve is not strictly needed for the running of the pump, but if the vacuum relief valve is not mounted, make sure that the cooling system is properly dimensioned).

Upon reaching the adjusted vacuum rate, the valve opens allowing the pump to intake atmospheric air.

The valve must be placed along the suction line.

NOTE *For continuous duty operating of the vacuum pump at vacuum rates and performances close to the maximum limits please contact Jurop's Technical Department.*

Layout of a hydraulic drive for Mod. PR150-200-250

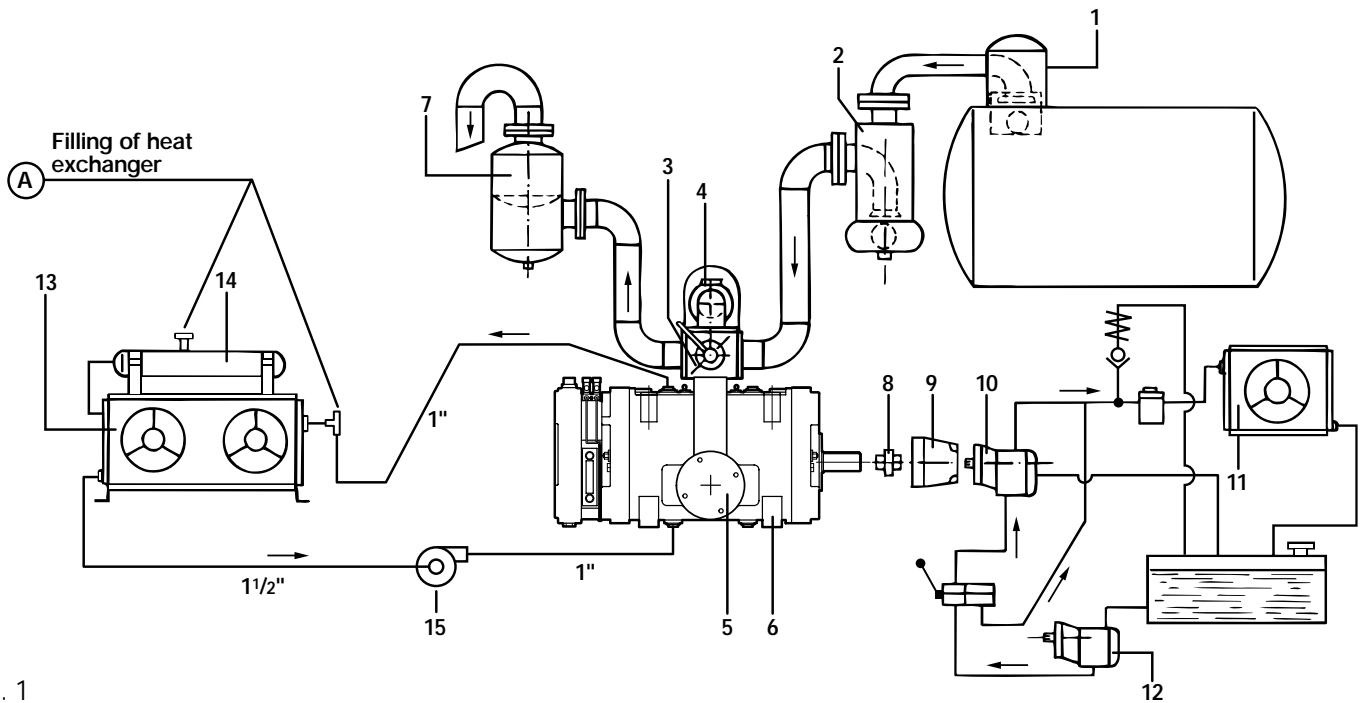

Fig. 1

| Installation | | | | | |
|--------------|------|--------------|--------------|--------------|----------------------------|
| Components | Pos. | PR150 Code | PR200 Code | PR250 Code | Description |
| Vacuum line | 1 | 18450.001.00 | 18450.001.00 | 18450.001.00 | Primary shutoff |
| | 2 | 14450.020.00 | 14450.025.00 | 14450.025.00 | Secondary shutoff cyclone |
| | 3 | 14881.009.00 | 14881.010.00 | 14881.010.00 | 4 way valve pneum. |
| | 4 | 14933.008.00 | 14933.009.00 | 14933.009.00 | Check valve |
| | 5 | 14450.029.00 | 14450.032.00 | 14450.032.00 | Air filter |
| | 6 | A2908.001.30 | A2708.001.30 | A2808.001.30 | Vacuum pump c.w. |
| | 7 | 15470.014.00 | 15470.014.00 | 15470.017.00 | Silencer/Oil separator |
| Transmission | 8 | 14701.018.00 | 14701.019.00 | 14701.019.00 | Coupling |
| | 9 | 16125.025.00 | 16125.024.00 | 16125.024.00 | Hydromotor mounting flange |
| | 10 | 4024.1070.04 | 40241.070.03 | 4024.1070.07 | Hydraulic motor |
| | 11 | 4021.5010.31 | 4021.5010.31 | 4021.5010.41 | Air-oil cooler |
| | 12 | 4024.2050.04 | 4024.2050.09 | 4024.2050.03 | Hydraulic pump |
| Cooling | 13 | 4021.5010.22 | 4021.5010.22 | 4021.5010.12 | Air-water cooler |
| | 14 | 14873.002.00 | 14873.002.00 | 14873.002.00 | Expansion tank |
| | 15 | 14072.008.00 | 14072.008.00 | 14072.008.00 | Water recycling pump c.w. |

Mechanical transmission of Mod. PR150-200-250

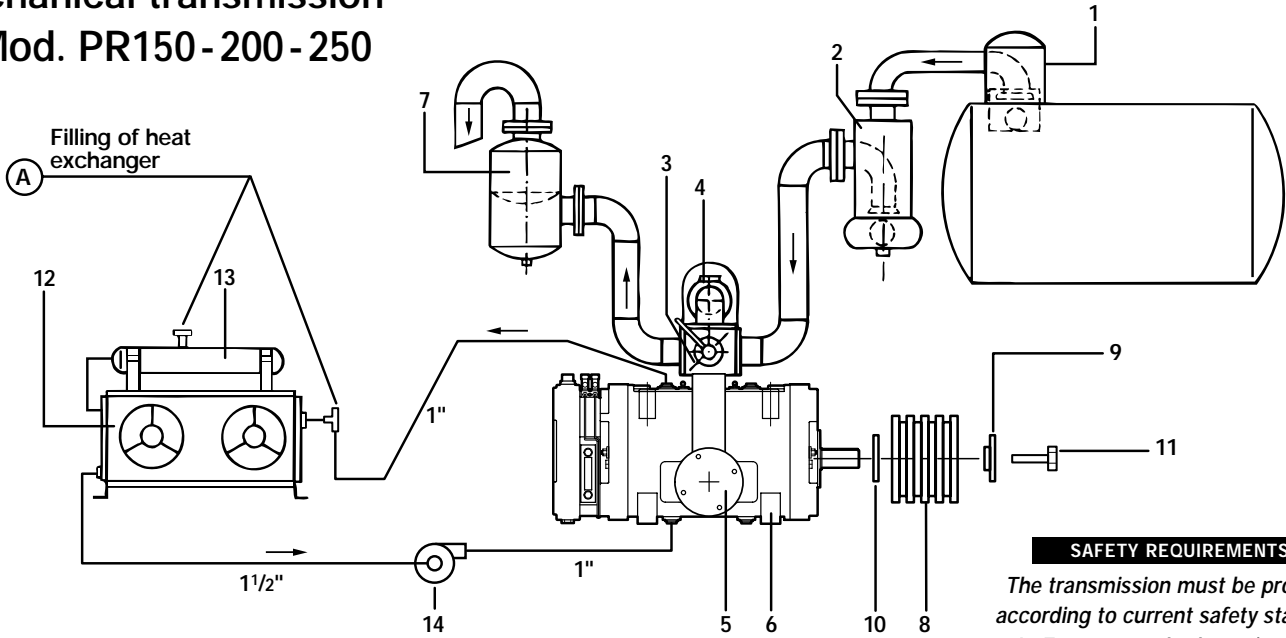

Fig. 2

SAFETY REQUIREMENTS
The transmission must be protected according to current safety standards. In Europe standard n°89/392 CEE.

| Installation | | | | | |
|--------------|------|--------------|--------------|--------------|---------------------------|
| Components | Pos. | PR150 Code | PR200 Code | PR250 Code | Description |
| Vacuum line | 1 | 18450.001.00 | 18450.001.00 | 18450.001.00 | Primary shutoff |
| | 2 | 18440.007.00 | 18440.007.00 | 18440.007.00 | Secondary shutoff |
| | 3 | 14881.009.00 | 14881.010.00 | 14881.010.00 | 4 way valve |
| | 4 | 4027.4003.09 | 4027.4003.09 | 4027.4003.09 | Check valve |
| | 5 | 14450.002.00 | 14450.005.00 | 14450.004.00 | Air filter |
| | 6 | A2908.001.30 | A2708.001.30 | A2808.001.30 | Vacuum pump c.w. |
| | 7 | 15470.013.00 | 15470.016.00 | 15470.016.00 | Silencer/Oil separator |
| Transmission | 8 | 16535.023.00 | 16525.024.00 | 16535.024.00 | Pulley |
| | 9 | 16850.036.00 | 16850.037.00 | 16850.037.00 | Fixing washer |
| | 10 | 16240.137.00 | 16240.138.00 | 16240.138.00 | Keep plate |
| | 11 | 4026.1074.14 | 4026.1074.14 | 4026.1074.14 | Screw M 14x40 |
| Cooling | 12 | 4021.5010.21 | 4021.5010.21 | 4021.5010.11 | Air-water cooler |
| | 13 | 14873.002.00 | 14873.002.00 | 14873.002.00 | Expansion tank |
| | 14 | 14072.008.00 | 14072.008.00 | 14072.008.00 | Water recycling pump c.w. |

SAFETY REQUIREMENTS

The transmission must be protected according to current safety standards. In Europe standard n. 89/392 CEE.

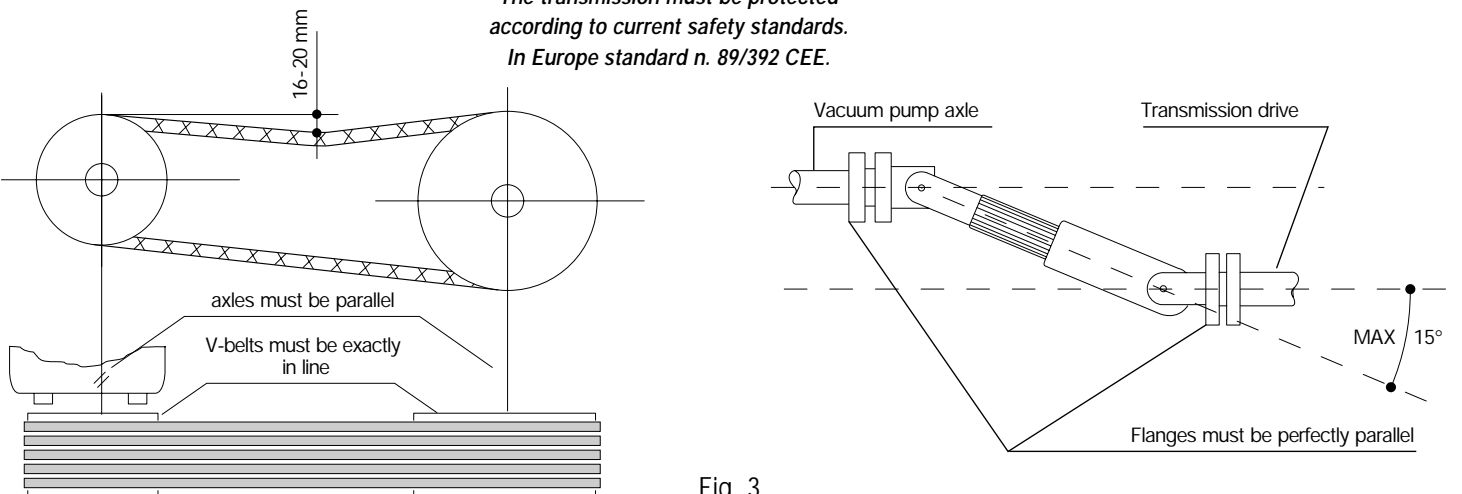
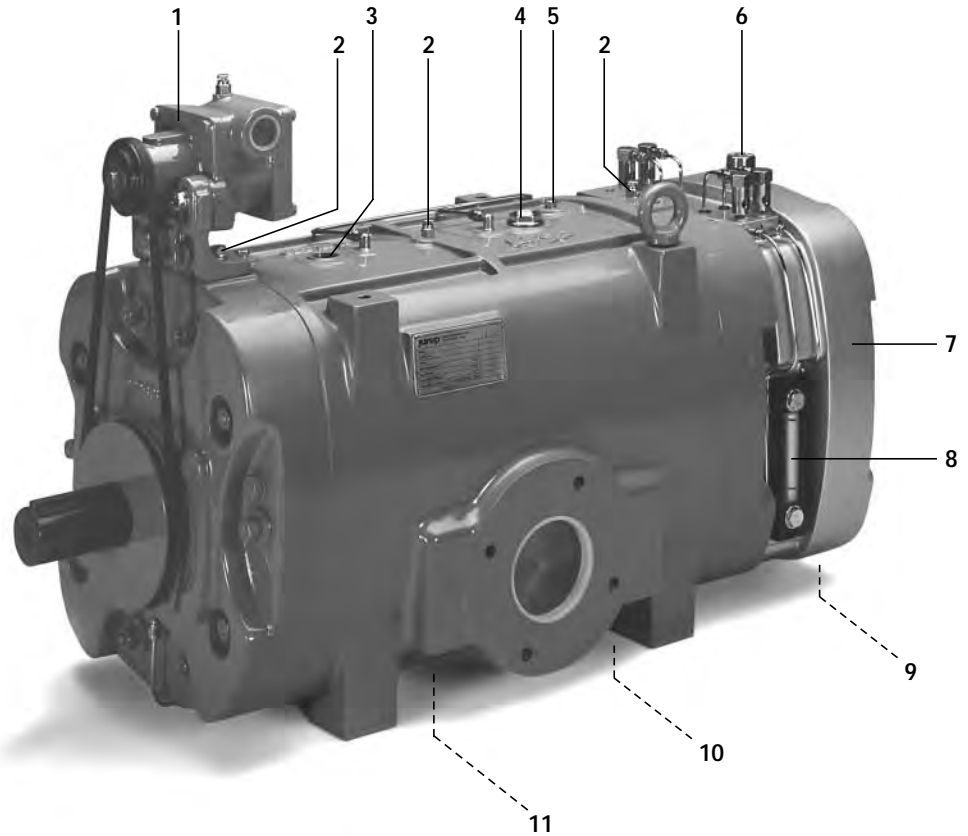

Fig. 3

3 First running of the system

Legend:

- 1 Water recycling pump
- 2 Vent of pump housing and flanges
- 3 Cooling liquid outlet
- 4 Water filling tap
- 5 Vanes inspection port
- 6 Oil filling tap
- 7 Oil tank
- 8 Oil sight glass
- 9 Oil tank drain
- 10 Cooling liquid inlet
- 11 Draining tap of pump housing



Attention:

The suction line and the vacuum tank must be provided with safety valves. To alter the adjustment of such valves may cause serious damage or danger of explosion.

Fig. 4

3.1 Fill the oil tank up to about 3 cm. below the filling tap - Pos. 6 - Fig. 4.

For the selection of the lubricating oil see Pag. 4.

3.2 After releasing the vent taps Pos. 2 - Fig. 4 overfill the pump housing with the cooling media through the tap of Pos. 4 - Fig. 4.

Fill up the heat exchanger through the taps shown at point A of the installing layouts of Pag. 8-9 - pos. A.

The expansion tank must be half filled, checking the level through the sight glass.

Screw on all the filling taps and vents.

The whole cooling system as shown has an approximate capacity of 30÷50 l. for the PR 150÷250.

During the wintertime antifreeze glicole must be added with the following percentages:

- 20% down to minus 10° C
- 35% down to minus 20° C
- 50% down to minus 30° C

Important:

Vent with care both the vacuum pump and the whole system.

3.3 Open all the valves of the vacuum system.

3.4 Check the correct rotation and run the pump for a few seconds.

3.5 While the pump is running check the following:

- a) The oil must drip inside the oilers.
(25÷30 drops per minute at the suggested pump speed)
- b) The rate of vacuum and pressure.

3.6 The oil pump is adjusted during the assembling of the vacuum pump.

For the flow see the performance chart at Pag. 4.

4 Maintenance of the vacuum pump

4.1 Lubrication

Check time by time through the sight glass of the drip oilers that the drops of oil flow regulary.

If this does not happen stop the pump immediately and check the oil level and the oil pump.

Drain daily the oil from the exauster/oil separator. Do not re-use such oil.

If the vacuum pump happens to run without lubrication it will heat up and could consequently be damaged.

In case of field adjustment of the oil flow see the following instructions and in case contact **Jurop's** Technical Departments:

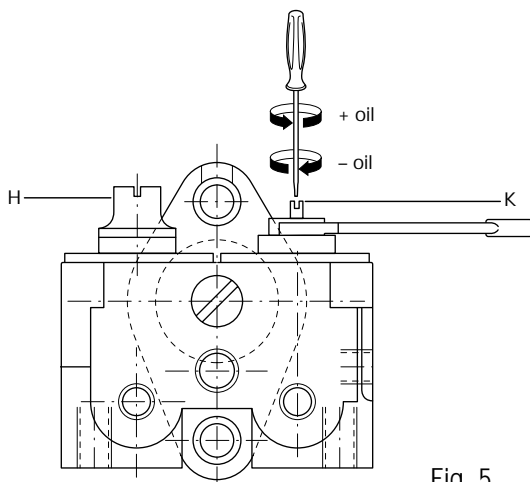

Fig. 5

- Screw of the filling and draining taps of Pos. 1-3 - Fig. 4.
- Unscrew the screws fixing the access flange of the oil tank.
- Take off the protection caps "H" of fig. 5
- With a short screw driver and spanner screw or unscrew the plug "K" of Fig. 5.
- Reset everthing and fill up with oil.

NOTE Never reduce the oil flow which is shown at pag. 4.

4.2 Performance control

Check time by time the vacuum rate of the pump.

If it does not reach the nominal value, it means that there could be wear of inside parts.

Proceed immediately with the measure of the vanes wear and with a thorough cleaning of the inside of the vacuum pump. (see points 4.4 and 4.5)

4.3 Temperature of the cooling liquid

The temperature of the cooling liquid should never exceed 60° C. If this happens check the whole cooling system and the operating of the vacuum pump.

4.4 Intake of liquids

In case of malfunction of the primary or secondary shutoff some liquid could flow from the tank into the vacuum pump. In this case the pump must be washed out by sucking about 2 l. of diesel fuel through a suitable tap placed on the suction line. Run the pump, shut off the tap and check the performances of the pump.

NOTE This operation must last not more than 30". If necessary repeat such operation after 10'.

Drain the diesel fuel from the oil trap of the exauster after the cleaning.

4.5 Checking the wear of the vanes

The wear of the vanes can be checked without taking apart the pump.

Unscrew the plug Pos. 5 -Fig. 4 and insert a rod of dia. 6 mm. and turn the shaft by hand. With the checking rod touching the outside diameter of the rotor, mark it a first time with a scriber (The rod is supplied with the pump).

Continue turning the shaft till the checking rod falls inside a vane groove touching the vane.

Mark the rod a second time. If the distance between the two marks exceeds 10 mm. the vanes must be replaced (see Fig. 6).

Once finished the checking procedure replace the plug Pos. 5.

NOTA «Min» e «max» marks are already traced on the rod supplied with the pump.

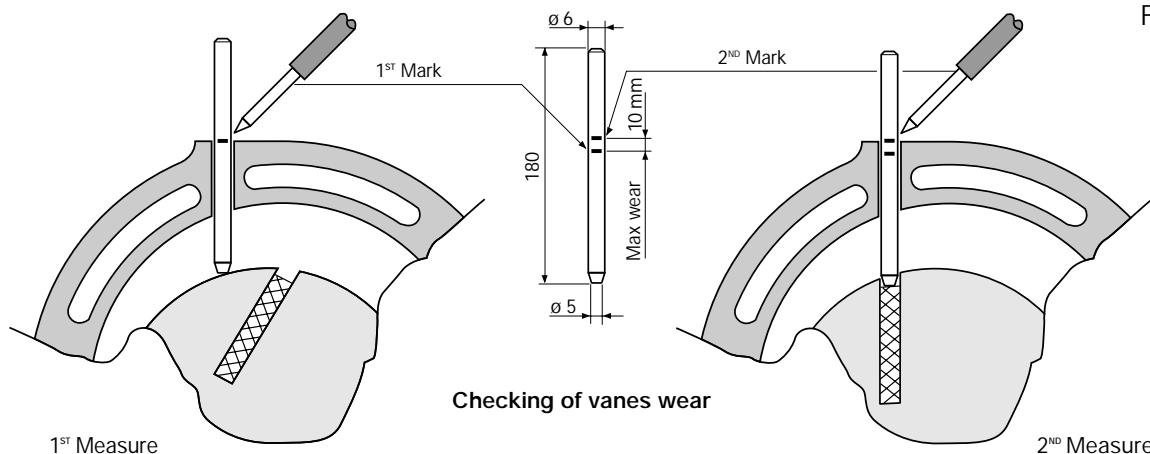

Fig. 6

Checking of vanes wear

1st Measure

2nd Measure

4.6 Replacement of the vanes

When replacing the vanes proceed as following (fig. 7):

- a) Drain the cooling liquid from the pump housing (Pos. 11 - Fig. 4).
- b) Remove the lubrication pipeline Pos. 27.
- c) Remove the key Pos. 96.
- d) Unscrew all the nuts Pos. 78 and take off the flange Pos. 8.
- e) Pull out the vanes Pos. 4 and clean the grooves of the rotor.
- f) Replace the vanes and lubricate them thoroughly.
- g) Replace the gasket Pos. 35
- h) Assemble all the parts taking care to lubricate all the gaskets (pos. 47-48) and the bearing. Align the flange by the steady pins (pos. 92) supplied with the pump.
- i) Tighten the nuts pos. 78 by means of a dynamometric wrench adjusted at 88 Nm and pull out the N° 2 steady pins.
- l) Refill the cooling system as shown at Pag. 10 - Paragraph 3.2 and re-install the pipeline pos. 27.

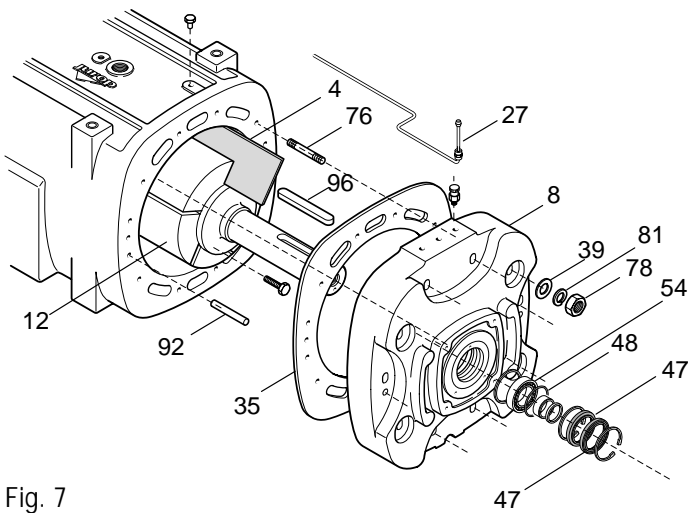

Fig. 7

4.7 Cleaning of suction filter

For weekly maintenance or in case of intake of liquid operate as follows (fig. 8):

- a) Remove the filtering cartridge
- b) Clean with detergent or diesel fuel and with a jet of air.
- c) When replacing the lid taking care of the exact positioning of the o-ring gasket

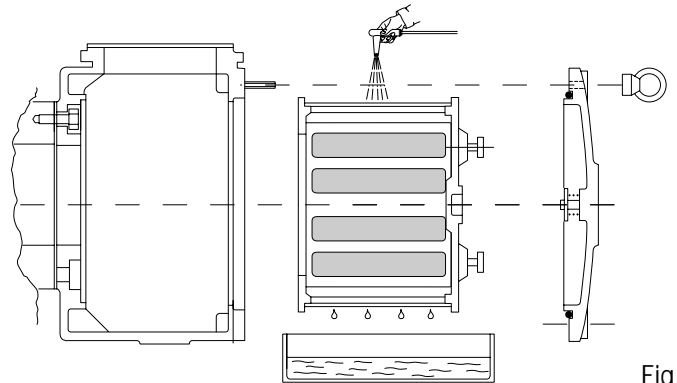

Fig. 8

4.8 Preliminary maintenance

| Operation | Daily | Weekly | Quarter |
|-----------------------------------|-------|--------|---------|
| Oil level checking | • | | |
| Pressure and vacuum checking | • | | |
| Pressure relief valve control | | • | |
| Cooling media temperature control | • | | |
| Cleaning of suction filter | | • (1) | |
| Wear of vanes | | | • |

(1) And in case of liquid intake

4.9 Trouble-shooting

TROUBLES

| A. The pump overheats | |
|---|---|
| Cause | Correction |
| • Faulty lubrication. | • Check the lubrication system and the oil pump. |
| • Oil missing. | • Re-fill the tank. |
| • Revolutions too high. | • Reduce revolutions. |
| • Operation-time too long at too high vacuum. | • Operate at lower vacuum rate (See point 2.9 - pag. 7). |
| • Reduced cooling. | • Check the performances of the centrifugal water recycling pump, the correct design and efficiency of the heat exchanger and check and vent thoroughly the whole cooling system. |

| B. The pump does not run | |
|--|---|
| Cause | Correction |
| • Broken vanes due to suction of foreign objects or bad lubrication or excess of wear. | • Take apart the pump and replace damaged parts. Check primary shut-off and lubrication system. |
| • Frozen pump. | • Unfreeze the vacuum pump. |
| • Damaged drive system. | • Check and replace damaged parts. |

| C. Reduced performances of the pump (vacuum/pressure/air flow) | |
|--|---|
| Cause | Correction |
| • Change-over 4 way valve in neutral position. | • Check position of inside baffle (cock) and manual lever or pneumatic actuator. |
| • Worn sliding-vanes. | • Replace the vanes. |
| • Loose check-valve. | • Replace the valve. |
| • Worn sealing rings. | • Replace the rings. |
| • Blocked vacuum pump. | • See previous instructions (point B). |
| • Leaking of the gate-valves of the tank. | • Tighten the valves or replace them. |
| • Leaking of the seals of the tank. | • Repair or replace the seals. |
| • Primary shut-off blocked. | • Dismount and clean the parts. |
| • Clogged connecting pipeline | • Clean the steel pipelines or replace the rubber ones. |
| • The suction filter is clogged | • Clean the cartridge. |
| • Accessories and whole vacuum line undersized | • Check the design according to the maximum performances of the vacuum pump (see pag. 4). |

5 Spare parts list

5.1 How to order the spare parts

To avoid mistakes when ordering the spare parts make sure you indicate:

- a) The model of the pump.
 - b) The serial number of the pump.
 - c) The denomination of the part.
 - d) The number of pieces.
 - e) The code of the part.
- } See pump label
 } See spare parts list

Example:

- a) PR150
- b) X70012
- c) Vane
- d) N. 6 pieces
- e) 1601605000