

HXL3F

Vacuum / Pressure Pump

Masport have been manufacturing vacuum/pressure pumps for over 100 years, so you can be sure of engineering excellence.

The Masport range of HXL pumps are specifically designed and engineered to meet the needs of hard working pumpers around the world.

To produce our precision pumps, we only use the finest quality components and materials to ensure the durability of your vacuum pump.

Every pump is factory tested before shipping and is backed up by a one year warranty against all manufacturing defects.

With Masport on board you have an efficient and reliable pump backed by the best service and support that has made Masport the #1 choice for pumpers worldwide.



Masport quality and performance

- ▶ Achieve minimum 27" Hg (Intermittent)
- ▶ Precise machining and assembly
- ▶ Heavy duty bearings
- ▶ Viton oil seals for longer service life
- ▶ Kevlar vanes are heat stabilized and machined with exacting tolerances for superior ruggedness and durability
- ▶ Superior pump life
- ▶ Mechanical oil pump with automatic oiling that delivers the right amount of oil at all working levels – no adjustment required
- ▶ Durable translucent high temperature oil lines – allows visible flow of oil to the pump
- ▶ End Thrust Protection prevents rotor to-endcover contact created by direct PTO drive or misaligned belt driven systems
- ▶ 1½" NPT bolt-on valve flanges for ease of installation
- ▶ ¼" NPT vane flush port
- ▶ Double end shaft accommodates clockwise or counter-clockwise drive systems
- ▶ Exclusive porting design providing multiple inlet and outlet porting configurations allowing for greater plumbing ease and versatility
- ▶ Easy to service
- ▶ One year performance warranty



112 CFM

Free Air Displacement



BUILT FOR THE HARD WORKING PUMPER

HXL3F

Vacuum / Pressure Pump

Performance Data – Vacuum

PUMP R.P.M	DISPLACEMENT C.F.M	S.C.F.M and A.C.F.M @ VACUUM											MAXIMUM VACUUM – “Hg	
			5	10	15	18	20	22	24	25	26	27	CONTINUOUS	INTERMITTENT
1250	78	SCFM	64	50	38	29	24	18	14	11	8	6	20	27
		ACFM	77	76	75	71	70	69	68	67	64	57		
1425	91	SCFM	73	58	43	33	27	21	15	12	9	6.2	20	27
		ACFM	88	87	86	82	81	77	75	74	69	62		
1750	112	SCFM	97	77	54	43	35	27	20	16	12	8.2	20	27
		ACFM	110	109	108	102	101	99	98	96	91	82		

Performance Data – Pressure

PUMP R.P.M	DISPLACEMENT C.F.M	S.C.F.M @ P.S.I.G							MAXIMUM PRESSURE – P.S.I.G	
		5	10	15	18	20	25	30	CONTINUOUS	INTERMITTENT
1250	78	71	67	64	61	59	56	54	15	15
1425	91	83	79	75	72	68	66	63	15	15
1750	112	102	97	92	88	84	81	77	15	15

Horsepower Required @ “Hg

PUMP R.P.M	VACUUM “Hg				
	5	10	15	20	27
1250	2.4	2.8	3.0	3.4	3.9
1425	2.8	3.3	3.5	3.9	4.5
1750	4.0	4.7	5.0	5.7	6.5

Horsepower Required @ P.S.I.G

PUMP R.P.M	P.S.I.G		
	5	10	15
1250	3.5	5.0	6.3
1425	4.0	5.8	7.3
1750	5.0	7.1	9.0

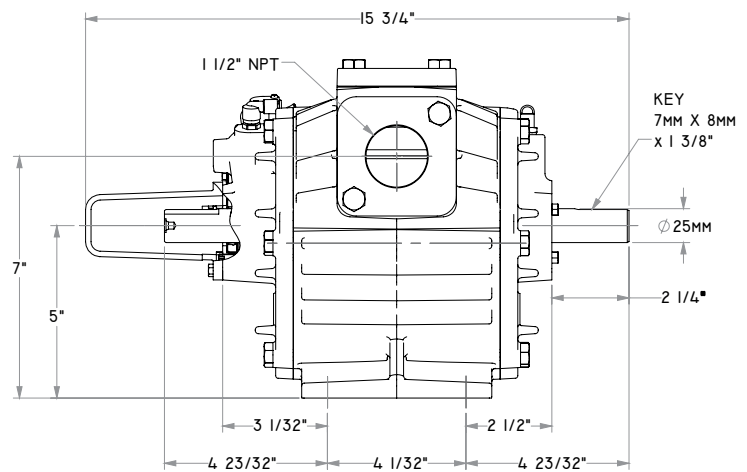
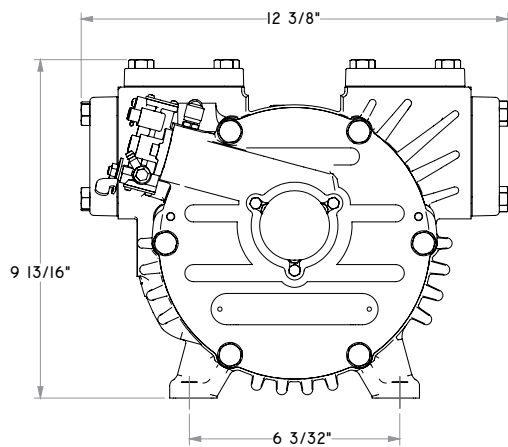

Superior reliability and performance features built into every Masport pump



Oil Reservoir and Flushing Kits available with either plastic or steel reservoirs



Automatic adjustment free mechanical oil pump



Extend pump life by installing a Flushing Kit



Heat stabilized Kevlar vanes machined to exacting tolerances

