

Oil Separator
(Pump Connection
Through Side Port)



Oil Separator with Demister Pad
(Pump Connection Through Top)

Masport Oil Separator

The Masport Oil Separator is designed to capture exhaust oil thus eliminating mess and clean up. The Oil Separator is made of precision-welded steel, pressure tested to ensure air-tightness. Like all Masport components the Oil Separator is available painted or unpainted. The Masport Oil Separator is available in a variety of porting sizes (1 1/2", 2 1/2", and 3" N.P.T.) and comes with heavy duty mounting brackets for ease of installation.

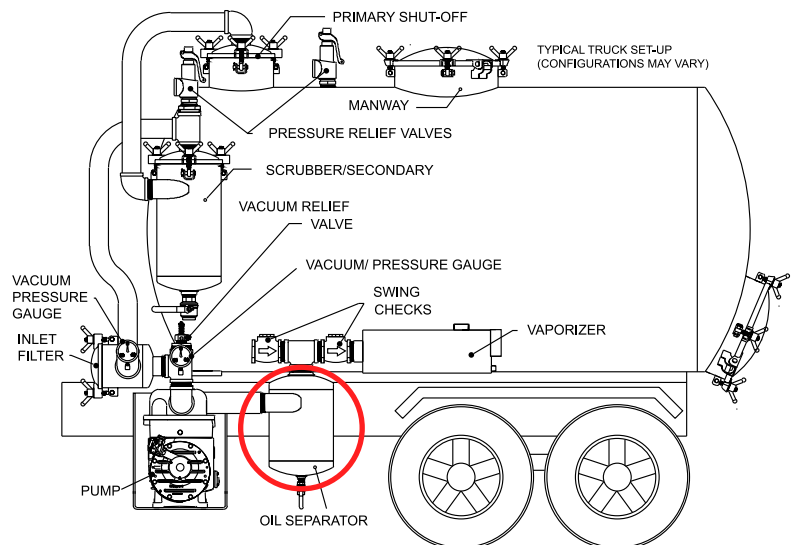

Typical Truck Set-Up (Configurations May Vary)

DIMENSIONAL DATA

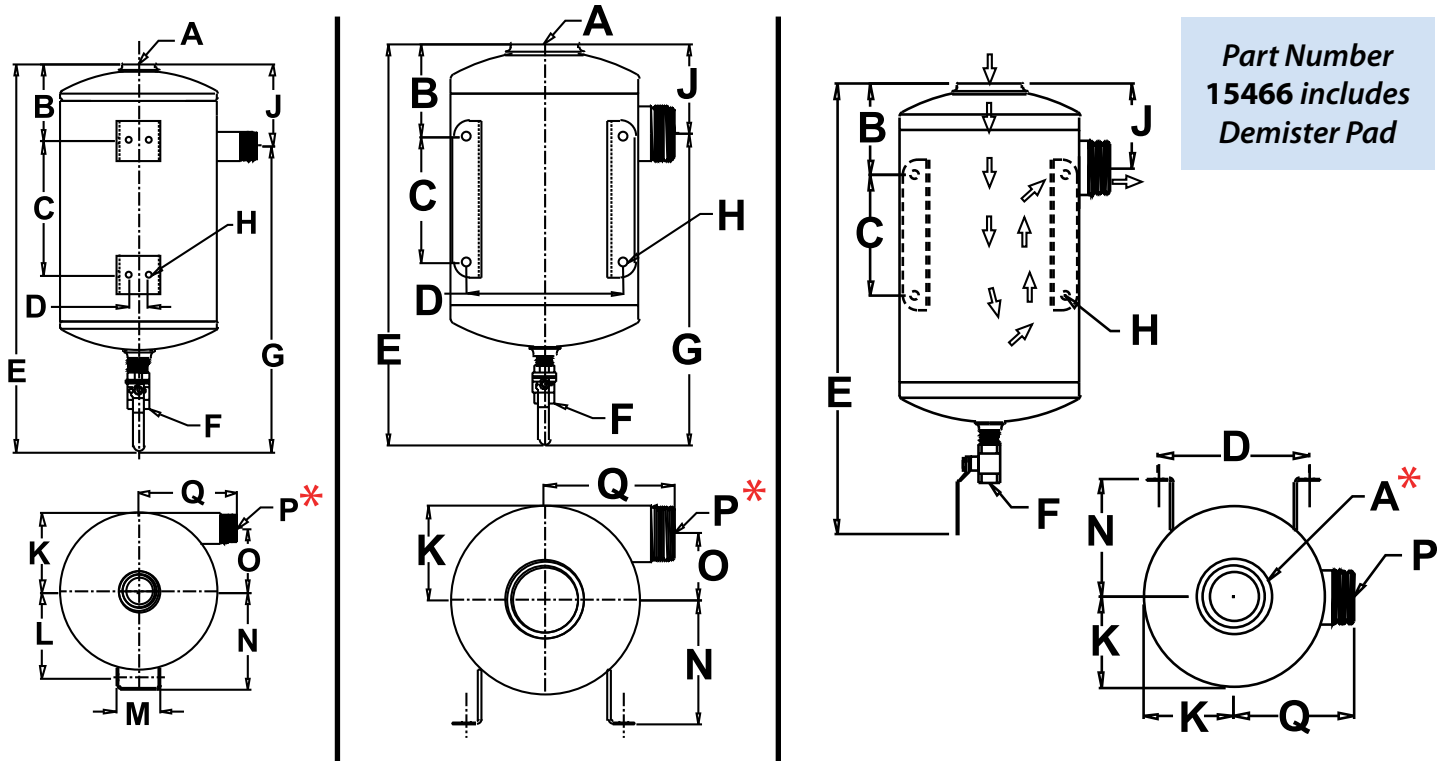

* PUMP CONNECTION

Oil Separator

Assembly Numbers

	15461	15462-5	15463	15464-3	15466
A	1 1/2" FNPT	1 1/2" FNPT	2 1/2" FNPT	3" FNPT	3" FNPT
B	4 7/16"	4 15/16"	5 1/8"	5 15/16"	6 1/16"
C	4 3/8"	8 1/2"	8 1/2"	8"	8"
D	1 1/4"	1 1/4"	1 1/4"	10"	10"
E	19 1/4"	24 5/8"	24 7/8"	25 9/16"	29 15/16"
F	3/4" FNPT	3/4" FNPT	3/4" FNPT	3/4" FNPT	3/4" FNPT
G	15 1/8"	19 7/16"	19 15/16"	19 13/16"	24 3/8"
H	3/8"	3/8"	3/8"	9/16"	9/16"
J	4 1/8"	5 3/16"	4 15/16"	5 3/4"	5 9/16"
K	4"	5"	5"	6"	6"
L	4 7/16"	5 7/16"	5 7/16"	-----	-----
M	2 3/4"	2 3/4"	2 3/4"	-----	-----
N	5 3/16"	6 1/4"	6 1/4"	7 7/8"	7 7/8"
O	3 1/16"	4 1/16"	3 9/16"	4 1/4"	-----
P	1 1/2" MNPT	1 1/2" MNPT	2 1/2" MNPT	3" MNPT	3" MNPT
Q	6 1/4"	6 5/16"	8 3/8"	8 5/16"	8"