

Titan

MASPORT
VACUUM PUMP SYSTEMS

Vacuum / Pressure Pump

Masport have been manufacturing vacuum/pressure pumps for over 100 years, so you can be sure of engineering excellence.

The Masport Titan has been specifically designed and engineered to meet the needs of hard working pumpers around the world.

To produce our precision pumps, we only use the finest quality components and materials to ensure the durability of your vacuum pump.

Every pump is factory tested before shipping and is backed up by a one year warranty against all manufacturing defects.

With Masport on board you have an efficient and reliable pump backed by the best service and support that has made Masport the #1 choice for pumpers worldwide.

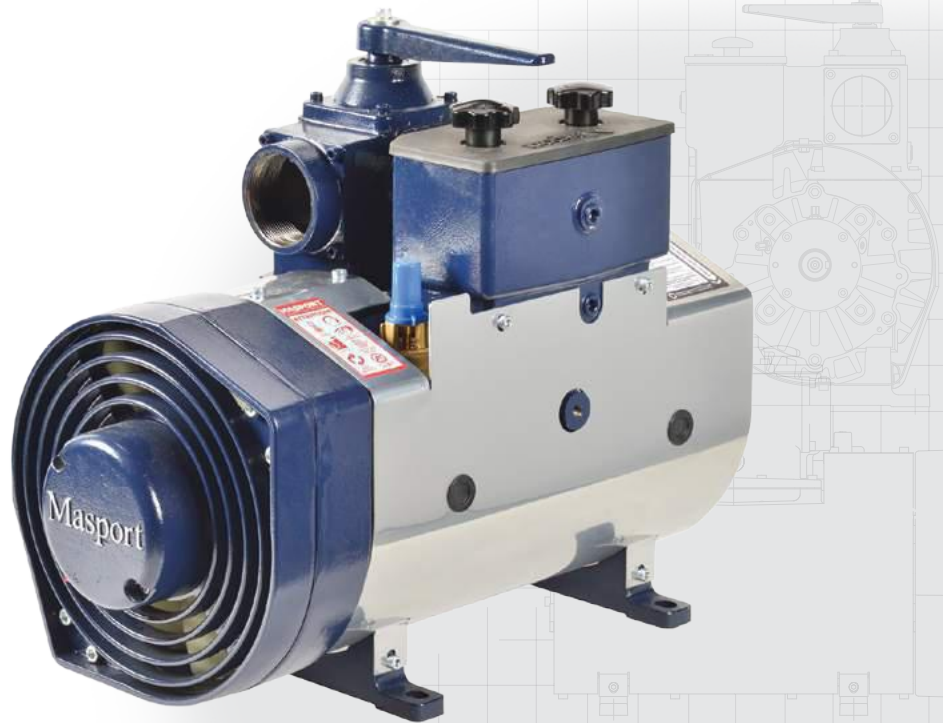

Masport quality and performance

- ▶ **Achieve minimum 27" Hg** (Intermittent)
- ▶ **Fan-cooled** for higher continuous vacuum operations
- ▶ **Precise machining and assembly**
- ▶ **Heavy duty bearings**
- ▶ **Viton oil seals** for longer service life
- ▶ **Kevlar vanes** are heat stabilized and machined with exacting tolerances for superior ruggedness and durability
- ▶ **Vane wear inspection ports**
- ▶ **Superior pump life**
- ▶ **Integrated inlet filter** – washable stainless steel design for long filter life
- ▶ **Mechanical oil pump** with automatic oiling that delivers the right amount of oil at all working levels – no adjustment required
- ▶ **Durable translucent high temperature oil lines** – allows visible flow of oil to the pump
- ▶ **Integral mounting bosses** guarantee precise alignment for hydraulic drive or gearbox mount applications
- ▶ **End Thrust Protection** prevents rotor to-endcover contact created by direct PTO drive or misaligned belt driven systems
- ▶ **3" NPT bolt-on valve flanges** for ease of installation
- ▶ **¼" NPT vane flush port**
- ▶ **Integral vacuum relief valve**
- ▶ **Integral valve** allows the pump to operate in vacuum and pressure mode and reduces plumbing and installation costs
- ▶ **O-Ring Endcovers** eliminates air or oil leakages
- ▶ **Easy to service**
- ▶ **One year performance warranty**

Pump available in Plug & Play and Tractor Pack Systems



407 CFM

Free Air Displacement



BUILT FOR THE HARD WORKING PUMPER

Titan

Vacuum / Pressure Pump

Performance Data – Vacuum

PUMP R.P.M	DISPLACEMENT C.F.M	S.C.F.M and A.C.F.M @ VACUUM											MAXIMUM VACUUM – “Hg	
			5	10	15	18	20	22	24	25	26	27	CONTINUOUS	INTERMITTENT
1200	343	SCFM	247	187	132	100	81	60	42	22	13	5	22	27
		ACFM	297	282	264	250	246	229	214	136	101	50		
1400	407	SCFM	345	282	215	152	117	94	67	48	24	15	20	27
		ACFM	377	340	326	304	293	285	259	241	152	112		

Performance Data – Pressure

PUMP R.P.M	DISPLACEMENT C.F.M	S.C.F.M @ P.S.I.G							MAXIMUM PRESSURE – P.S.I.G	
		5	10	15	18	20	25	30	CONTINUOUS	INTERMITTENT
1200	343	285	251	244	239	233	230	215	20	30
1400	407	377	313	297	283	279	275	270	20	30

Horsepower Required @ “Hg

PUMP R.P.M	VACUUM “Hg				
	5	10	15	20	27
1200	15	15	15	15	15
1400	19	19	19	19	19

Horsepower Required @ P.S.I.G

PUMP R.P.M	P.S.I.G					
	5	10	15	20	25	30
1200	20	22	26	30	35	38
1400	25	27	31	36	40	45

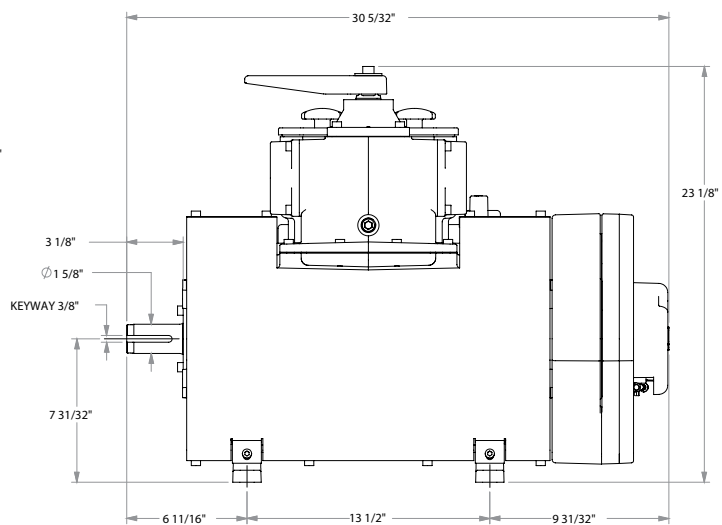
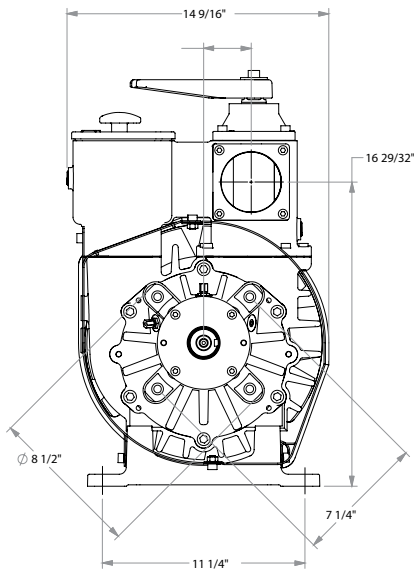

Superior reliability and performance features built into every Masport pump



Washable stainless steel Inlet Filter for long filter life



Integral mounting bosses guarantee alignment with gearbox and hydraulic mount



Automatic adjustment free mechanical oil pump



Heat stabilized Kevlar vanes machined to exacting tolerances

