

Viper

Vacuum / Pressure Pump

MASPORT
VACUUM PUMP SYSTEMS

Masport have been manufacturing vacuum/pressure pumps for over 100 years, so you can be sure of engineering excellence.

The Masport Viper has been specifically designed and engineered to meet the needs of hard working pumpers around the world.

To produce our precision pumps, we only use the finest quality components and materials to ensure the durability of your vacuum pump.

Every pump is factory tested before shipping and is backed up by a one year warranty against all manufacturing defects.

With Masport on board you have an efficient and reliable pump backed by the best service and support that has made Masport the #1 choice for pumpers worldwide.

Pump available in Plug & Play and Tractor Pack Systems

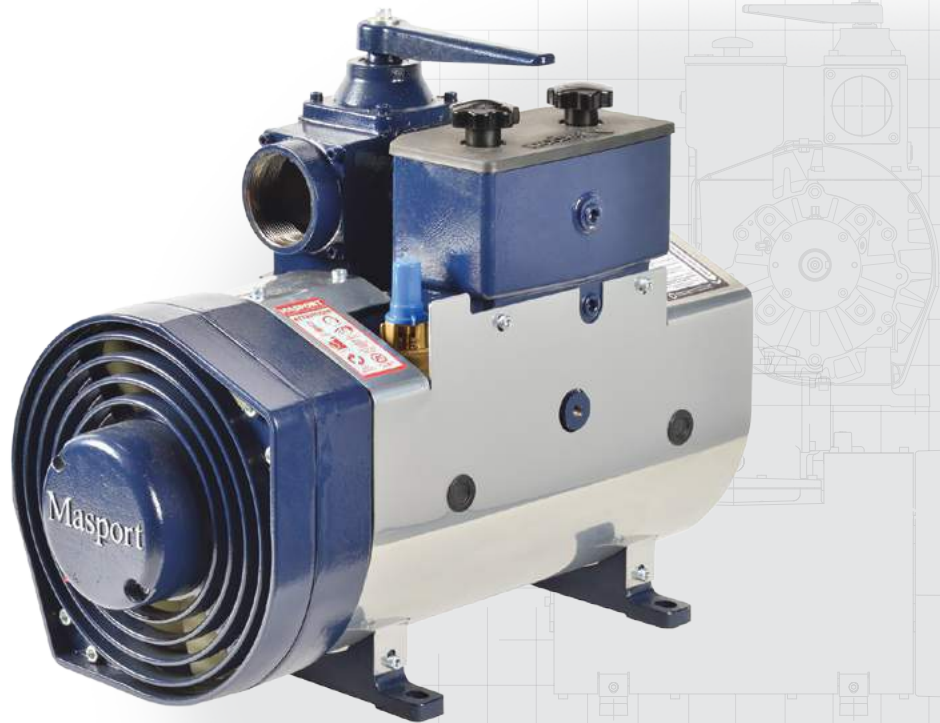

Masport quality and performance

- ▶ **Achieve minimum 27" Hg** (Intermittent)
- ▶ **Fan-cooled** for higher continuous vacuum operations
- ▶ **Precise machining and assembly**
- ▶ **Heavy duty bearings**
- ▶ **Viton oil seals** for longer service life
- ▶ **Kevlar vanes** are heat stabilized and machined with exacting tolerances for superior ruggedness and durability
- ▶ **Vane wear inspection ports**
- ▶ **Superior pump life**
- ▶ **Integrated inlet filter** – washable stainless steel design for long filter life
- ▶ **Mechanical oil pump** with automatic oiling that delivers the right amount of oil at all working levels – no adjustment required
- ▶ **Durable translucent high temperature oil lines** – allows visible flow of oil to the pump
- ▶ **Integral mounting bosses** guarantee precise alignment for hydraulic drive or gearbox mount applications
- ▶ **End Thrust Protection** prevents rotor to-endcover contact created by direct PTO drive or misaligned belt driven systems
- ▶ **3" NPT bolt-on valve flanges** for ease of installation
- ▶ **¼" NPT vane flush port**
- ▶ **Integral vacuum relief valve**
- ▶ **Integral valve** allows the pump to operate in vacuum and pressure mode and reduces plumbing and installation costs
- ▶ **O-Ring Endcovers** eliminates air or oil leakages
- ▶ **Easy to service**
- ▶ **One year performance warranty**

350 CFM

Free Air Displacement



BUILT FOR THE HARD WORKING PUMPER

Viper

Vacuum / Pressure Pump

Performance Data – Vacuum

PUMP R.P.M	DISPLACEMENT C.F.M	S.C.F.M and A.C.F.M @ VACUUM											MAXIMUM VACUUM – “Hg	
			5	10	15	18	20	22	24	25	26	27	CONTINUOUS	INTERMITTENT
1100	303	SCFM	211	165	120	90	71	54	31	23	15	5	22	27
		ACFM	253	248	239	225	213	201	153	136	113	52		
1250	350	SCFM	246	175	139	104	83	62	38	26	16	6	22	27
		ACFM	295	289	278	261	248	233	192	158	118	60		

Performance Data – Pressure

PUMP R.P.M	DISPLACEMENT C.F.M	S.C.F.M @ P.S.I.G							MAXIMUM PRESSURE – P.S.I.G	
		5	10	15	18	20	25	30	CONTINUOUS	INTERMITTENT
1100	303	254	242	231	217	204	192	180	20	30
1250	350	293	279	266	251	235	222	207	20	30

Horsepower Required @ “Hg

PUMP R.P.M	VACUUM “Hg				
	5	10	15	20	27
1100	10	12	13	14	15
1250	12	14	15	16	18

Horsepower Required @ P.S.I.G

PUMP R.P.M	P.S.I.G					
	5	10	15	20	25	30
1100	14	18	22	27	31	35
1250	16	20	26	31	36	40

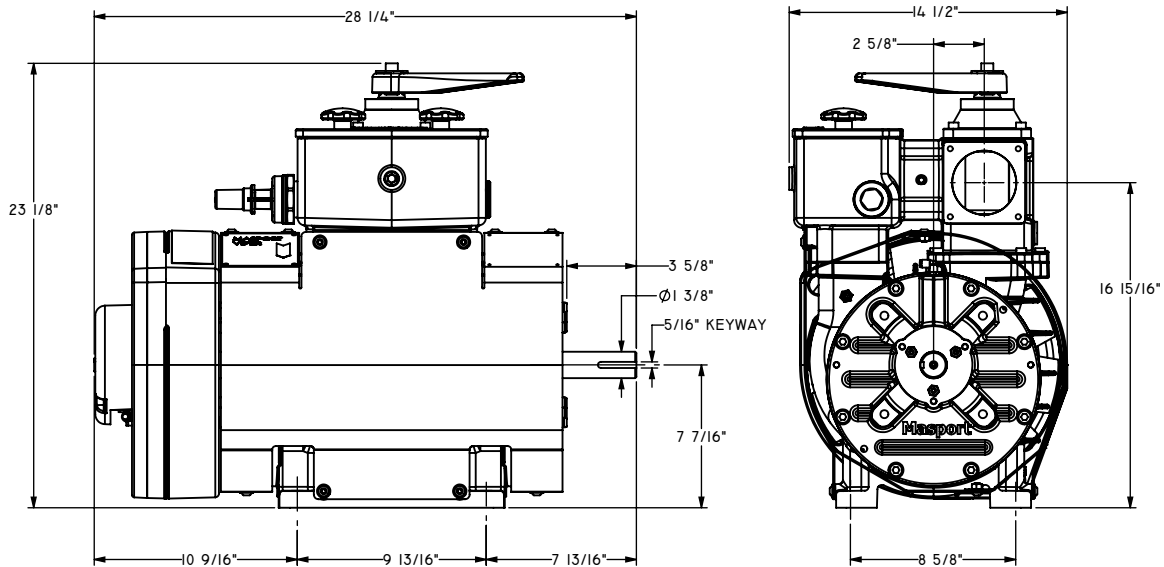

Superior reliability and performance features built into every Masport pump



Washable stainless steel Inlet Filter for long filter life



Integral mounting bosses guarantee alignment with gearbox and hydraulic mount



Automatic adjustment free mechanical oil pump



Heat stabilized Kevlar vanes machined to exacting tolerances

