

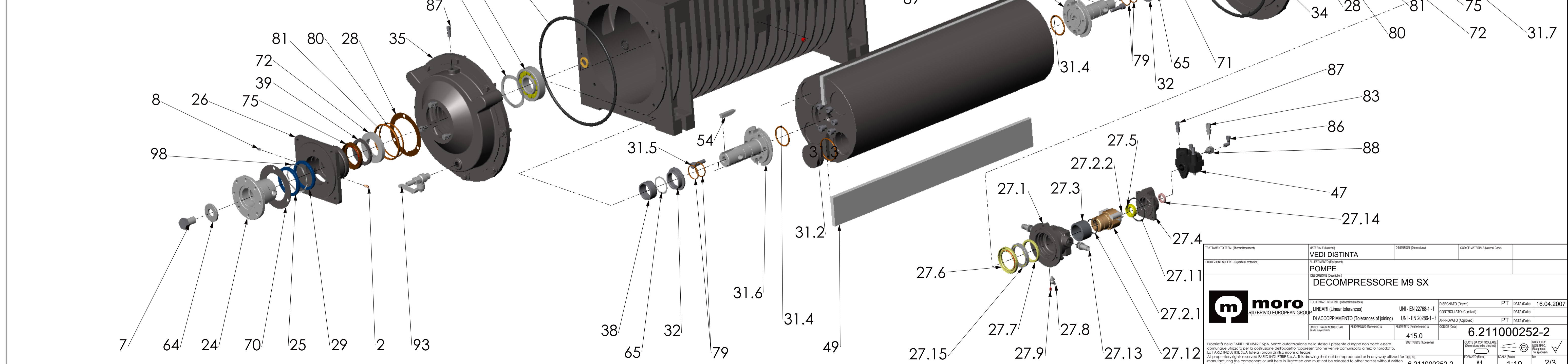

|     |               |                               |                            |      |
|-----|---------------|-------------------------------|----------------------------|------|
| 102 | 6.965038102-2 | VOJANT DE NIVEAU HUILE        | OELANZEIGER                | 1    |
| 101 | 6.965029002-2 | BOUCHON M1&1.5                | STÖPSEL M1&1.5             | 1    |
| 100 | 6.964014005-2 | RONDELLE EN CUIVRE            | DICHTRING                  | 2    |
| 99  | 6.963005004-2 | ANNEAU Ø80                    | RING Ø80                   | 2    |
| 98  | 6.963005004-2 | ANNEAU DE COMPENSATION Ø80    | AUSGLEICH RING Ø80         | 1    |
| 97  | 6.931021002-2 | ROULEMENT 40x90x23 (N308ECJ3) | LAGER 40x90x23 (N308ECJ3)  | 2    |
| 96  | 6.925070000-2 | BOUCHON 1/8"                  | DECKEL 1/8"                | 2    |
| 95  | 6.925046003-2 | RACCORD 3/4"                  | ANSCHLUß 3/4"              | 1    |
| 94  | 6.925046001-2 | RACCORD 3/8"x13               | ANSCHLUß 3/8"x13           | 1    |
| 93  | 6.925029001-2 | ROBINET 3/8"x14               | WASSERHAHN 3/8"x14         | 2    |
| 92  | 6.925005005-2 | BOUCHON 1 1/4"                | STÖPSEL 1 1/4"             | 4    |
| 91  | 6.925004001-2 | RACCORD 3/4"                  | NIPPEL 3/4"                | 1    |
| 90  | 6.925003001-2 | RACCORD TT 3/8"               | ANSCHLUß TT 3/8"           | 1    |
| 89  | 6.925002003-2 | MONTAGE 90° 3/4"              | FITTING 90° 3/4"           | 1    |
| 88  | 6.924085000-2 | RACCORD "L" M10x1-1/8"        | ANSCHLUß "L" M10x1-1/8"    | 1    |
| 87  | 6.924043050-2 | RACCORD Ø4-1/8"               | ANSCHLUß Ø4-1/8"           | 6    |
| 86  | 6.924061050-2 | RACCORD 90° Ø4-1/8"           | ANSCHLUß 90° Ø4-1/8"       | 2    |
| 85  | 6.924042120-2 | RACCORD 3/4"-1/4"             | ANSCHLUß 3/4"-1/4"         | 2    |
| 84  | 6.924019000-2 | RACCORD 90° Ø6-M10x1          | ANSCHLUß 90° Ø6-M10x1      | 1    |
| 83  | 6.924017007-2 | RACCORD Ø6-1/8"               | ANSCHLUß Ø6-1/8"           | 1    |
| 82  | 6.922002002-2 | BANDE                         | SCHELLE                    | 2    |
| 81  | 6.921003502-2 | ANNEAU OR 5.34x89.69x100.37   | O-RING 5.34x89.69x100.37   | 2    |
| 80  | 6.921003501-2 | ANNEAU OR 3.53x88.45x95.55    | O-RING 3.53x88.45x95.55    | 2    |
| 79  | 6.921003500-2 | ANNEAU OR 2.62x34.60x39.84    | O-RING 2.62x34.60x39.84    | 4    |
| 78  | 6.921003236-2 | ANNEAU OR 6.99x285.10x299.08  | O-RING 6.99x285.10x299.08  | 3    |
| 77  | 6.921003137-2 | ANNEAU OR 3.53x110.72x117.78  | O-RING 3.53x110.72x117.78  | 2    |
| 76  | 6.921003100-2 | ANNEAU OR 3.53x20.22x27.28    | O-RING 3.53x20.22x27.28    | 1    |
| 75  | 6.921002000-2 | ANNEAU DÉTANCHÉITÉ 72x48x10   | SIMMERRING 72x48x10        | 2    |
| 74  | 6.690000210-2 | SOUPAPE                       | VENTIL                     | 4    |
| 73  | 6.690000000-2 | RESSORT                       | FEDER                      | 1    |
| 72  | 6.685000040-2 | ANNEAU DÉTANCHÉITÉ            | SIMMERRING                 | 2    |
| 71  | 6.685000560-2 | ANNEAU ÉLASTIQUE              | SPRITZRING                 | 1    |
| 70  | 6.685000550-2 | ANNEAU                        | RING                       | 1    |
| 69  | 6.684500000-2 | BOUCHON HUILE 3/4"            | ÖL-STOPFEN 3/4"            | 2    |
| 68  | 6.683300070-2 | RONDELLE EN CUIVRE            | DICHTRING                  | 2    |
| 67  | 6.683300030-2 | RONDELLE EN CUIVRE            | DICHTRING                  | 2    |
| 66  | 6.683300020-2 | RONDELLE                      | FEDERSCHIBE                | 2    |
| 65  | 6.683001400-2 | ANNEAU                        | RING                       | 2    |
| 64  | 6.683000100-2 | RONDELLE                      | SCHIBE                     | 1    |
| 63  | 6.683000000-2 | RONDELLE DE SÉCURITÉ          | SICHERHEIT SCHIBE          | 1    |
| 62  | 6.680600810-1 | JOINT                         | DICHTUNG                   | 1    |
| 61  | 6.680600800-2 | JOINT                         | DICHTUNG                   | 4    |
| 60  | 6.680600000-2 | JOINT                         | DICHTUNG                   | 1    |
| 59  | 6.676011220-2 | HUILE TUYAU                   | ÖLLEITUNG                  | 1    |
| 58  | 6.676011210-2 | HUILE TUYAU                   | ÖLLEITUNG                  | 1    |
| 57  | 6.676011200-2 | HUILE TUYAU                   | ÖLLEITUNG                  | 1    |
| 56  | 6.676011193-2 | HUILE TUYAU                   | ÖLLEITUNG                  | 1    |
| 55  | 6.676011180-2 | HUILE TUYAU                   | ÖLLEITUNG                  | 1    |
| 54  | 6.675000010-2 | CLAVETTE                      | FEDER                      | 1    |
| 53  | 6.673000350-2 | VALVE STOP                    | VENTIL STOP                | 2    |
| 52  | 6.673000250-2 | RACCORD                       | ANSCHLUß                   | 1    |
| 51  | 6.671000810-2 | PLAQUE                        | PLATTE                     | 2    |
| 50  | 6.662400460-2 | CORPS GAUCHE M9               | GEHÄUSE INKS M9            | 1    |
| 49  | 6.657501040-1 | PALETTE M9                    | LAMELLE M9                 | 2    |
| 48  | 6.657500000-2 | TUYAU D'EAU                   | WASSERLEITUNGSROHR         | 1    |
| 47  | 6.652400110-1 | POMPE À HUILE GAUCHE          | ÖLpumpe LINKS              | 1    |
| 46  | 6.644500000-2 | FILTRE HUILE                  | ÖLFILTER                   | 1    |
| 45  | 6.640400010-2 | COUVERCLE                     | DECKEL                     | 1    |
| 44  | 6.633000020-2 | AXE                           | STIFT                      | 1    |
| 43  | 6.633000010-2 | AXE                           | STIFT                      | 1    |
| 42  | 6.633000000-2 | AXE                           | STIFT                      | 2    |
| 41  | 6.624400091-2 | COLLECTEUR M9-M15             | PUMPENBEITEL M9-M15        | 1    |
| 40  | 6.624400040-2 | DÉVIATEUR M9-M15              | UMSCHALTVORRICHTUNG M9-M15 | 1    |
| 39  | 6.622200010-2 | ENTRETOISE                    | ABSTANDSTÜCK               | 2    |
| 38  | 6.622007280-1 | BAGUE                         | BUCHSE                     | 1    |
| 37  | 6.621000090-2 | PRISONNIER                    | STIFTSCHRAUBE              | 1    |
| 36  | 6.610400370-2 | SOUTIEN ARRIERE               | HINTEN SUPPORT             | 1    |
| 35  | 6.610400351-2 | REBORD AVANT GAUCHE           | FLANSCH VORNE LINKS        | 1    |
| 34  | 6.610400341-2 | RETOUR BRIDE M9               | FLANSCH NACHTRÄGLICH M9    | 1    |
| 33  | 6.610006201-2 | FLASQUE                       | FLANSCH                    | 2    |
| N°  | Codice / Code | DESCRIZIONE_FRANCESE          | DESCRIZIONE_TEDESCO        | Q.T. |

|        |               |                                |                                 |      |
|--------|---------------|--------------------------------|---------------------------------|------|
| 32     | 6.61000090-2  | BAGUE                          | BUCHSE                          | 2    |
| 31.7   | 6.61100090-2  | MOYEAU                         | NABE                            | 1    |
| 31.6   | 6.611000890-2 | MOYEAU                         | NABE                            | 1    |
| 31.5   | 47300310257   | VIS M10x35 TCEI                | SCHRAUBE M10x35 TCEI            | 12   |
| 31.4   | 6.921003504-2 | OR 3.53x49.21x56.27            | OR 3.53x49.21x56.27             | 2    |
| 31.3   | 6.921003503-2 | OR 3.53x55.56x62.62            | OR 3.53x55.56x62.62             | 8    |
| 31.2   | 6.684400010-2 | BOUCHON                        | GAP                             | 8    |
| 31.1   | 6.553400871-2 | ROTOR M9                       | LÄUFER M9                       | 1    |
| 31     | 6.475300141-2 | ROTOR COMPLET M9               | ROTOR KOMPLETT M9               | 1    |
| 30     | 6.453300100-2 | GRAISSEUR                      | OELER                           | 2    |
| 29     | 6.1047352-4-2 | ANNEAU DÉTANCHÉITÉ 65x80x7 BAB | SIMMERRING 65x80x7 (BAB)        | 1    |
| 28     | 6.1047324-9-2 | JOINT                          | DICHTUNG                        | 3    |
| 27.15  | 6.1046675-6-2 | ROULEMENT (61810)              | KUGELLAGER (61810)              | 1    |
| 27.14  | 6.1032243-9-2 | ROULEMENT 17x26x5 (61803-2RS1) | KUGELLAGER 17x26x5 (61803-2RS1) | 1    |
| 27.13  | 6.925046001-2 | RACCORD 3/8"x13                | ANSCHLUß 3/8"x13                | 2    |
| 27.12  | 6.921003054-2 | ANNEAU TORIQUE 34.6x39.84x2.62 | RUNDSCHNURRING 34.6x39.84x2.62  | 1    |
| 27.11  | 6.921003062-2 | ANNEAU TORIQUE 60x65.24x2.62   | RUNDSCHNURRING 60x65.24x2.62    | 1    |
| 27.10  | 6.657501050-1 | PALETTE                        | LAMELLE                         | 1    |
| 27.9   | 47310100008   | VIS SANS TÊTE M5x10 PG-UNIS927 | GEWINDESTIFT M5x10 PG-UNIS927   | 1    |
| 27.8   | 47630010009   | ENGRASSEUR                     | STAUFFER                        | 1    |
| 27.7   | 6.1047229-5-2 | ANNEAU DÉTANCHÉITÉ 50x62x7     | SIMMERRING 50x62x7              | 1    |
| 27.6   | 6.1047228-6-2 | ANNEAU DÉTANCHÉITÉ 50x72x8     | SIMMERRING 50x72x8              | 1    |
| 27.5   | 6.921000001-2 | ANNEAU DÉTANCHÉITÉ 18x35x10    | SIMMERRING 18x35x10             | 1    |
| 27.4   | 6.1046612-2-2 | SUPPORT DE POMPE A HUILE       | ÖLpumpe SUPPORT                 | 1    |
| 27.3   | 6.1046667-6-2 | BAGUE                          | BUCHSE                          | 1    |
| 27.2.3 | 47300310062   | VIS M5x16 TCEI 8.8 ZN          | SCHRAUBE M5x16 TCEI 8.8 ZN      | 2    |
| 27.2.2 | 6.1032210-8-2 | MAYEU DE LA POMPE DE L'EAU     | HUB DER WASSERPUMPE             | 1    |
| 27.2.1 | 6.1046418-8-2 | ROTOR                          | ROTOR                           | 1    |
| 27.2   | 6.1046434-8-2 | ROTOR DE POMPE A EAU           | WASSERPUMPENRAD                 | 1    |
| 27.1   | 6.1046669-4-2 | CORPS DE POMPE A EAU           | BODY DER WASSERPUMPE            | 1    |
| 27     | 6.1047232-0-2 | POMPE A EAU M9-PM200           | WASSERPUMPE M9-PM200            | 1    |
| 26     | 6.1047194-4-2 | SUPPORT AVANT M9               | FRONT SUPPORT M9                | 1    |
| 25     | 6.1047188-4-2 | ANNEAU DÉTANCHÉITÉ 65x80x7+7.5 | SIMMERRING 65x80x7+7.5          | 1    |
| 24     | 6.1018745-1-2 | MOYEU M9-PM200                 | NABE M9-PM200                   | 1    |
| 23     | 47300310115   | VIS UNIS931 M6x16 ZN           | SCHRAUBE UNIS931 M6x16 ZN       | 2    |
| 22     | 47350130019   | RONDELLE Ø12.2                 | SCHIBE Ø12.2                    | 6    |
| 21     | 47300250166   | VIS ISO 4018 M12x25            | SCHRAUBE ISO 4018 M12x25        | 6    |
| 20     | 47300250083   | VIS M8x25                      | SCHRAUBE M8x25                  | 2    |
| 19     | 47300250078   | VIS M8x20                      | SCHRAUBE M8x20                  | 2    |
| 18     | 47300250124   | VIS UNIS79 T.E. TF M10x1.5x25  | SCHRAUBE UNIS79 T.E. TF M10x1.5 | 8    |
| 17     | 47350130031   | RONDELLE Ø18.2                 | FEDERSCHIBE Ø18.2               | 1    |
| 16     | 47350130015   | RONDELLE D=10.2                | SCHIBE D=10.2                   | 16   |
| 15     | 47300250128   | VIS M10 X 30                   | SCHRAUBE M10 X 30               | 16   |
| 14     | 47300250087   | VIS M8x30 T.E. ZN 8.8          | SCHRAUBE M8x30 T.E. ZN 8.8      | 11   |
| 13     | 47300250090   | VIS M8x30 T.E. ZN 8.8          | SCHRAUBE M8x30 T.E. ZN 8.8      | 20   |
| 12     | 47350130011   | RONDELLE SCHIBE Ø8             | SCHIBE Ø8                       | 36   |
| 11     | 47300250094   | VIS TE M8x40                   | SCHRAUBE TE M8x40               | 3    |
| 10     | 47350190056   | RONDELLE 21x37                 | FEDERSCHIBE 21x37               | 1    |
| 9      | 47350160024   | RONDELLE                       | FEDERSCHIBE                     | 2    |
| 8      | 47310100015   | GOUJON M6x10 STEI 12K          | STIFTSCHRAUBE M6x10 STEI 12K    | 3    |
| 7      | 47300280022   | VIS M18x1.5x30 TE 8.8          | SCHRAUBE M18x1.5x30 TE 8.8      | 1    |
| 6      | 47320190041   | ÉCROU M18x1.5                  | MUTTER M18x1.5                  | 1    |
| 5      | 47320220017   | ÉCROU M20x1.5                  | MUTTER M20x1.5                  | 2    |
| 4      | 47530070005   | CHEVILLE À OUEILLÉ M12         | ISENSCHRAUBE M12                | 2    |
| 3      | 47370070041   | AXE Ø6x35                      | STIFT Ø6x35                     | 1    |
| 2      | 47630010005   | GRAISSEUR M6x1                 | GREASER M6x1                    | 1    |
| 1      |               | M9 GAUCHE                      | M9 LINKS                        | Q.T. |
| N°     | Codice / Code | DESCRIZIONE_FRANCESE           | DESCRIZIONE_TEDESCO             | Q.T. |



Le joint 62 peut être ceci ou no  
Kann die Anzahl 62 "Sein oder nicht versiegelt

|   |  |                                |  |                                  |  |
|---|--|--------------------------------|--|----------------------------------|--|
| MATERIALE (Material)  |  | DIMENSIONI (Dimensions)        |  | CODICE MATERIALE (Material Code) |  |
| VEDI DISTINTA   |  |                                |  |                                  |  |
| PROTEZIONE SUPERF. (Superficial protection)   |  |                                |  |                                  |  |
| POMPE   |  |                                |  |                                  |  |
| DESCRIZIONE (Description)   |  |                                |  |                                  |  |
| DECOMPRESSORE M9 SX   |  |                                |  |                                  |  |
| TOLLERANZE GENERALI (General tolerances)  |  | UNIS (Linear tolerances)       |  | DATA (Date)                      |  |
| LINEARI (Linear tolerances)   |  | UNI - EN 22768-1-f             |  | PT 16.04.2007                    |  |
| DI ACCOPPIAMENTO (Tolerances of joining)  |  | UNI - EN 20296-1-f             |  | PT                               |  |
| GRUPPI ENERGETICI (Energy groups)   |  | RESTRIZIONI (Restrictions)     |  | CODICE ENERGETICO (Energy code)  |  |
| 415.0   |  | 6.211000252-2                  |  | 6.211000252-2                    |  |
| Proprietà della FARDI INDUSTRIE S.p.A. Senza autorizzazione della stessa il presente disegno non potrà essere copiato o utilizzato per la costruzione dell'oggetto rappresentato né venire comunicato a terzi o riprodotto.   |  |                                |  |                                  |  |
| All proprietary rights reserved FARDI INDUSTRIE S.p.A. This drawing shall not be reproduced or in any way utilized for manufacturing the component or unit here in illustrated and must not be released to other parties without written consent. Any infringement will be legally pursued. |  |                                |  |                                  |  |
| Moro  |  | FARDI INDUSTRIE EUROPEAN GROUP |  | 6.211000252-2                    |  |
| A1  |  | 1:10                           |  | 2/3                              |  |

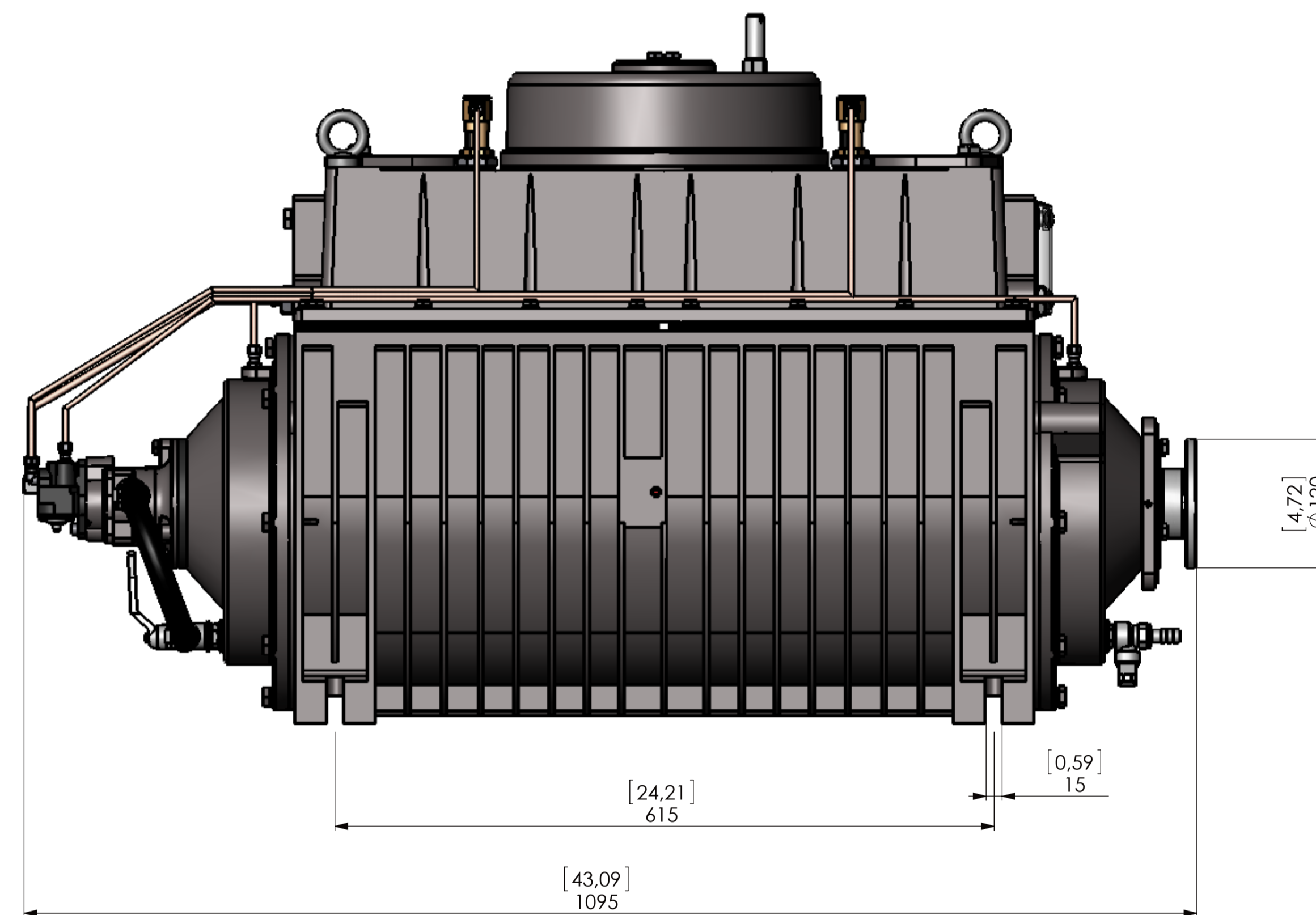
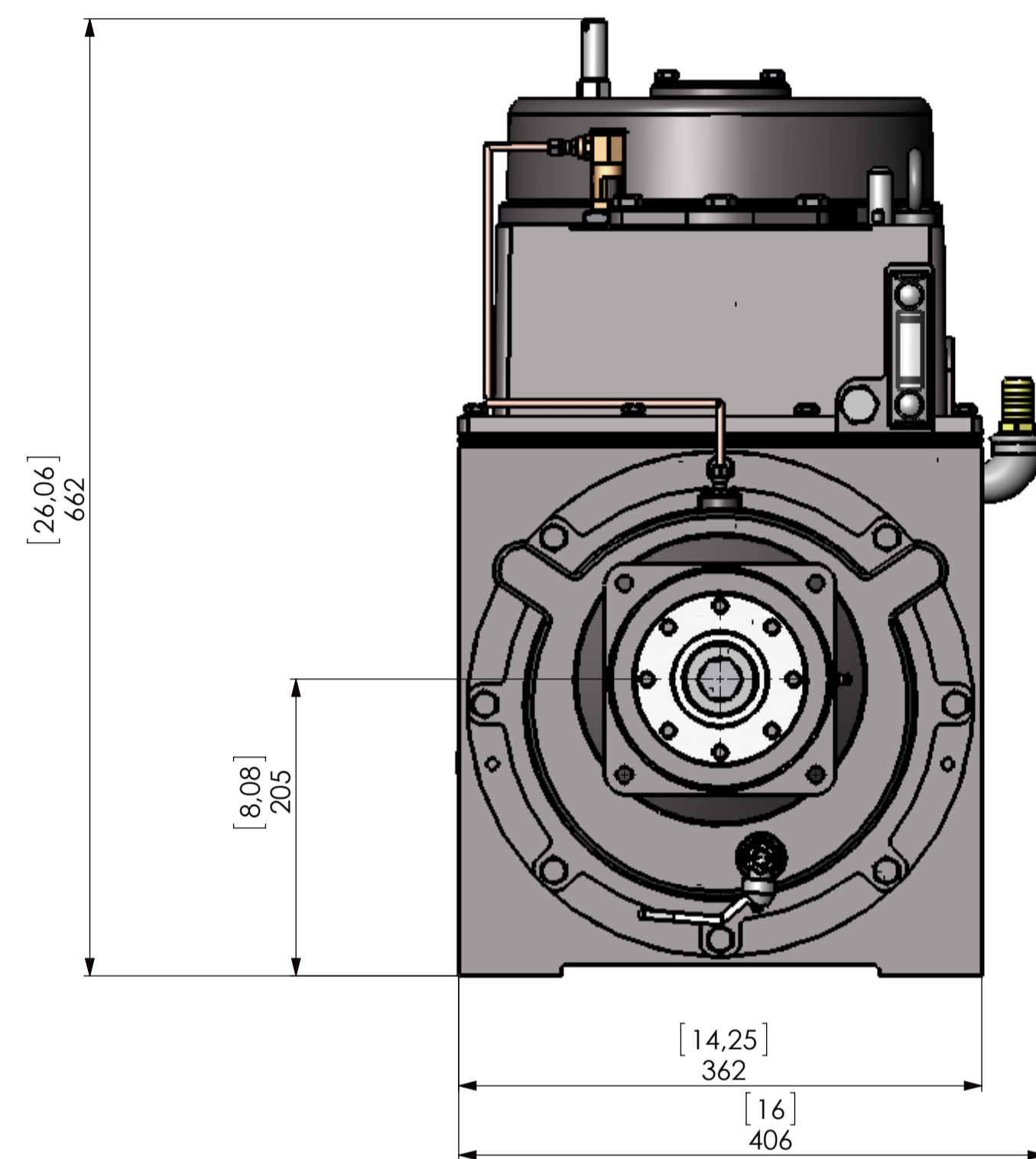

|  |                      |                         |                                  |
|--|----------------------|-------------------------|----------------------------------|
| TATTAMENTO TERM (Thermal treatment)  | MATERIALE (Material) | DIMENSIONI (Dimensions) | CODICE MATERIALE (Material Code) |
| PROTEZIONE SUPERF (Surface protection)   | VEDI DISTINTA        |                         |                                  |
| REVISIONE (Revision)   | POMPE                |                         |                                  |
|  | DECOMPRESSORE M9 SX  |                         |                                  |
| TOLLERANZE GENERALI (General tolerances)   | UNI - EN 22768-1-f   | DISCRETO (Discret)      | PT DATA (Date) 16.04.2007        |
| LINEARI (Linear tolerances)  | UNI - EN 20296-1-f   | CONTROLLATO (Checked)   | DATA (Date)                      |
| DI ACCOPPIAMENTO (Tolerances of joining)   | UNI - EN 20296-1-f   | APPROVATO (Approved)    | PT DATA (Date)                   |
| GRUPPI E TAGLI (Groups and cuts)   | 415.0                | CODICE EGRA             | 6.211000252-2                    |
| PROPRIETÀ DEL FARMO INDUSTRIE S.p.A. Senza autorizzazione dello stesso il presente disegno non potrà essere copiato o utilizzato per la costruzione dell'oggetto rappresentato né venire comunicato a terzi o riprodotto. La FARMO INDUSTRIE S.p.A. riserva i propri diritti di legge. All proprietary rights reserved FARMO INDUSTRIE S.p.A. This drawing shall not be reproduced or in any way utilized for manufacturing the component or unit here in substance and must not be released to other parties without written consent. Any infringement will be legally pursued. | 6.211000252-2        | AL                      | 1:10                             |
|  |                      |                         | 3/3                              |

