

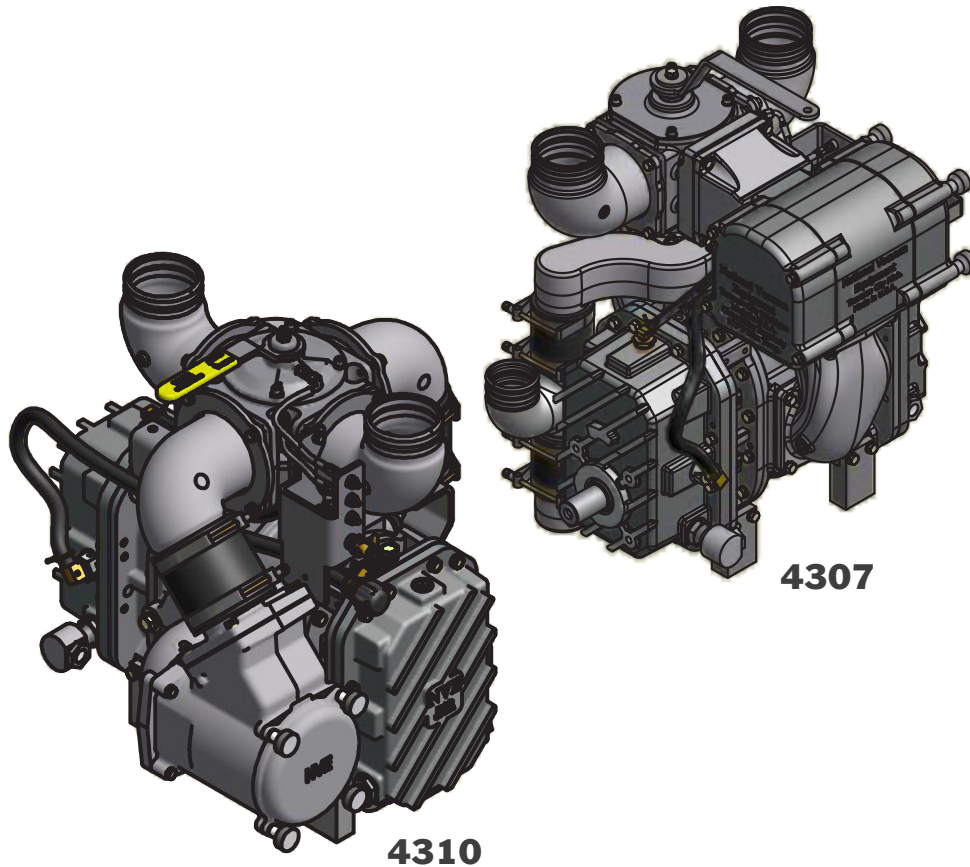

43 SERIES

HEAVY DUTY VACUUM BLOWERS

Proudly Distributed By:
**ARMSTRONG
 EQUIPMENT
 INC.**



Features

- Continuous duty performance at maximum vacuum
- Tri-lobe design with precision machining
- Ballast port manifold
 - cools blower through air injection
- Range of airflow
 - performance available to accommodate power
- Oil-less operation
- 4" hose barbed adjustable porting for the intake and exhaust
- Integral final filter with easy access cleaning
- 4-Way pressure/vacuum change over valve
- Designed, built, and supported in the USA

4307 CHALLENGER BLOWER SPECIFICATIONS

AIR FLOW - FREE AIR	560 CFM
*FULL VACUUM	
MAXIMUM PRESSURE	15 PSI
*FULL VACUUM - RECOMMENDED	4000 RPM
HP REQUIRED @ 27" HG	36.4
HP REQUIRED @ 10 PSI	28.4
HP REQUIRED @ 15 PSI	40.6
PORTING SIZE	4"
SHAFT SIZE (3/8" KEY)	1 1/2"
BLOWER DIMENSION	L 24 15/16" W 20 1/4" H 29 1/2"
APPROXIMATE WEIGHT	421 LBS

4310 CHALLENGER BLOWER SPECIFICATIONS

AIR FLOW - FREE AIR	940 CFM @ 4500 RPM
*FULL VACUUM	
MAXIMUM PRESSURE	15 PSI
*FULL VACUUM - RECOMMENDED	4000 RPM 4500 RPM
HP REQUIRED @ 27" HG	51.4 58
HP REQUIRED @ 10 PSI	39.7 44
HP REQUIRED @ 15 PSI	65.5 N/A
PORTING SIZE	4"
SHAFT SIZE (3/8" KEY)	1 1/2"
BLOWER DIMENSION	L 27 11/16" W 23 7/16" H 26 15/16"
APPROXIMATE WEIGHT	456 LBS

*The maximum allowable operating vacuum will vary depending on R.P.M., ambient temperature, altitude and time running. The basic principle to keep in mind is - faster R.P.M., higher air temperature and longer run time all equal more heat in blower. When installing an NVE 4307 or 4310 blower we recommend a normal R.P.M. of 4000. Other speeds are OK as long as exhaust gas temperatures read on the supplied thermometer do not exceed 380 degrees F. Maximum of 4500 R.P.M is for intermittent use only (4310).

Challenger Series
 VACUUM PUMPS & BLOWERS

Weights and measurements are
 for reference only

800-699-7557 | www.vacpump.com





43 SERIES HEAVY DUTY VACUUM BLOWERS

Proudly Distributed By:
**ARMSTRONG
EQUIPMENT
INC.**

Pro Pak Frame Mount Gearbox Drive

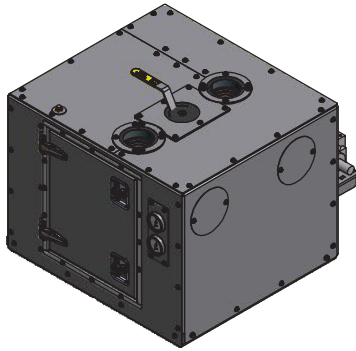

- 3/8" powder coat painted frame
- Stainless steel cabinet
- Easily accessible service points
- Blower flush kit
- Internal ballast silencing
- Ballast check valve for pressure operation
- 500 series right angle 1:2 ratio gearbox
 - 4307 - straight cut gear
 - 4310 - spiral beveled gear
- 4310 - L 45 1/2" W 35 7/16" H 26 15/16"
- 4307 - L 43 3/8" W 32 3/16" H 26 15/16"

Pro Pak Frame Mount Hydraulic Drive

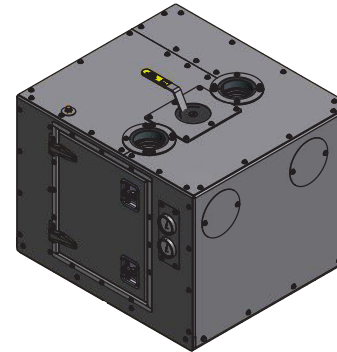

- 3/8" powder coat painted frame
- Stainless steel cabinet
- Easily accessible service points
- Blower flush kit
- Internal ballast silencing
- Ballast check valve for the pressure operation
- SAE C face hydraulic adapter
- 4310 - L 35 1/16" W 35 7/16" H 29 3/4"
- 4307 - L 33 7/16" W 32 3/16" H 29 15/16"

Pro Pack Frame Mount Belt Drive

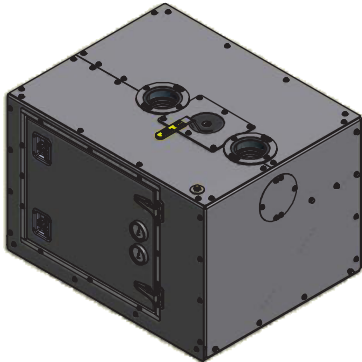

- 3/8" powder coat painted frame
- Stainless steel cabinet
- Easily accessible service points
- Blower flush kit
- Internal ballast silencing
- Ballast check valve for pressure operation
- Belt drive is 2.5:1 speed up ratio
- 4310 - L 46 15/16" W 39 11/16" H 29 3/4"
- 4307 - L 46 15/16" W 36 3/16" H 29 7/8"

Pro Pak Top Mount Hyd or Belt Drive

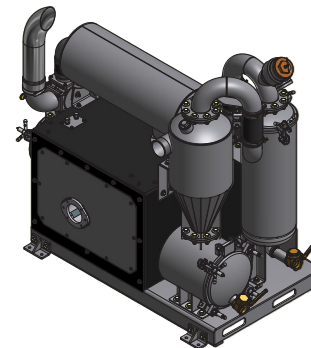

- 3/8" powder coat painted frame
- Stainless steel cabinet
- Easily accessible service points
- Blower flush kit
- Ballast check valve for the pressure operation
- Integral horizontal exhaust silencer
- Two Drive systems to choose from
 - SAE C Face hyd adapter
 - fully adjustable belt drive
- Available with moisture trap and cyclone
- L 81 3/4" W 37 1/8" H 67 1/8"

Pro Pack Belly Mount Hydraulic Drive

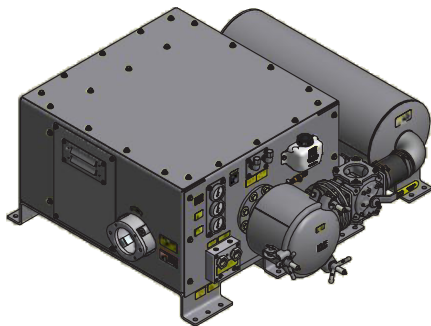

- 3/8" powder coat painted frame
- Stainless steel cabinet
- Easily accessible service points
- Blower flush kit
- Ballast check valve for the pressure operation
- Integral horizontal exhaust silencer
- SAE C face hydraulic adapter
- 4310 - L 58 5/8" W 58 5/8" H 26 5/8"
- 4307 - L 57" W 58 5/8" H 26 5/8"

