



607 PRO

HEAVY DUTY VACUUM PUMPS

Proudly Distributed By:
**ARMSTRONG
 EQUIPMENT
 INC.**



Features

- Lifetime warranty on the housing against cracking
- Ductile iron housing (tough like steel).
- The NVE bi-rotational, four port oil pump is exclusive to our “oil management system” delivering the precise amount of oil required for any job. Easily adjustable to 5-24 ounces per hour.
- Rugged braided stainless steel oil delivery lines
- Vacuum relief boss
- Vane flush port with valve
- Vane wear inspection port
- Integral, easily accessible, and cleanable stainless steel final filter
- Proven crash protection allowing all major components to survive a catastrophic failure
- Remote mount 5 quart see through oil tank for constant oil level monitoring
- Thermometer to monitor exhaust temperature
- Multiple drive options (gearbox, belt, hydraulic, and direct)
- Two year warranty against manufacturer defect
- Designed, built, and supported in the USA

FAN-COOLED OR LIQUID COOLED 607 PRO SPECIFICATIONS

AIR FLOW - FREE AIR	380 CFM
*MAXIMUM VACUUM	29" HG
MAXIMUM PRESSURE	30 PSI
*OPERATING RANGE - RPM	1250
HP REQUIRED @ VACUUM	25
HP REQUIRED @ 20 PSI	28
PORTING SIZE	3"
SHAFT SIZE (3/8" KEY)	1 1/2"
PUMP DIMENSIONS	L 29 5/8" W 14 9/16" H 32 11/16"
APPROXIMATE WEIGHT	390 LBS

*The maximum allowable operating vacuum will vary depending on R.P.M., ambient temperature, altitude and time running. The basic principle to keep in mind is - faster R.P.M., higher air temperature and longer run time all equal more heat in pump. When installing an NVE 607 pump we recommend a normal R.P.M. of 1250. Other speeds are ok as long as exhaust gas temperatures read on the supplied thermometer do not exceed 380 degrees F.

Challenger Series
 VACUUM PUMPS & BLOWERS

Weights and measurements are
 for reference only

800-699-7557 | www.vacpump.com



607 PRO HEAVY DUTY VACUUM PUMPS

607 PRO Hydraulic Motor Drive



- Heavy-duty automatic alignment bracket
- SAE B face 2 and 4 bolt flange
- Coupler set
- Additional fan shroud mounting bracket required for liquid cooled model
- L 41 7/16" W 23" H 15 15/16"

607 PRO Pump Stand Complete

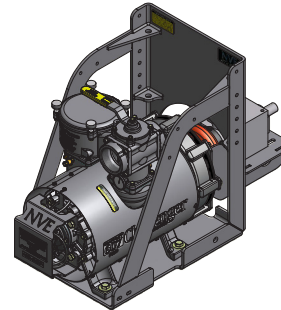

- Vacuum pump included; specify rotation and cooling type
- Package available as fan cooled and liquid cooled models
- 400 series three-shaft gearbox accommodates clockwise and counterclockwise rotation
- Coupler set with shear protection
- Easy-align, adjustable gearbox bracket
- Also available with hydraulic drive
- L 43 3/4" W 18" H 27 1/2"

607 PRO Muffler Package

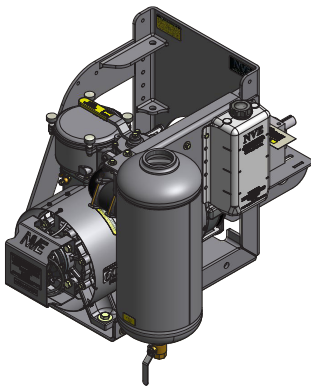

- Vacuum pump included; specify rotation, cooling type and muffler location (left or right).
- Round oil catch muffler has a compact design
- Stainless steel mesh filter
- All elbows, fittings and high temp hoses are factory connected
- Right-hand or left-hand muffler location available
- New Gearbox Bracket features
- Also available with hydraulic drive
- L 43 3/4" W 28 1/2" H 27 1/2"

607 PRO Max Package

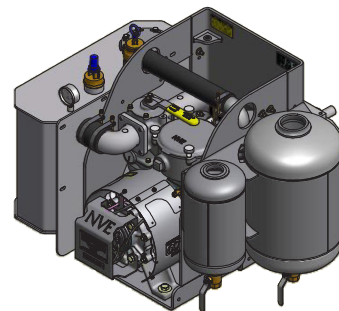

- Vacuum pump included; specify rotation, cooling type and muffler location (left or right).
- 12" round oil catch muffler
- Equipped with an 8" round oil catch muffler for pressure relief
- High efficiency aluminum moisture trap
- Accessible 6" stainless steel float ball
- BUNA positive shut-off ball seat
- 2" lever drain valve
- Blank intake flange standard (other fittings available)
- Vacuum/pressure relief valve and gauge
- All elbows, fittings and high temperature hoses are factory connected.
- L 43 7/8" W 42 3/8" H 28 1/2"

607 PRO Top of Frame Mount

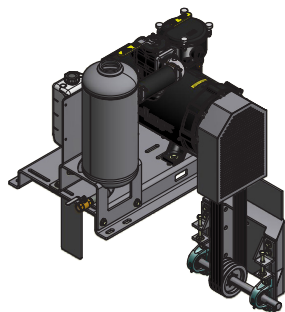

- Designed for top valve pump
- Mounting bracket that includes oil catch muffler with drain valve and remote oil tank
- Belts and u-bolts available separately
- All elbows, fittings and high temp hoses are factory connected
- Also available with hydraulic drive
- L 38" W 40" H 49 15/16"

607 PRO Engine Drive Package

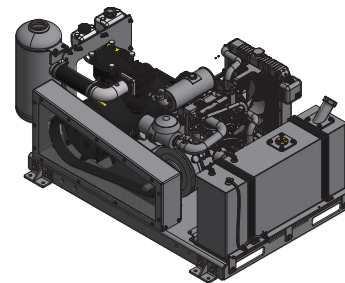

- Rugged, low profile for belly-mount application
- Diesel engine power unit with electric control
- 23 gallon steel fuel tank
- High efficiency oil catch muffler
- 12 volt high crank capacity battery
- Powder coat painted and factory assembled
- TIER 4 final tested and compliant
- All elbows, fittings and high temperature hoses are factory connected.
- L 72 7/16" W 55 1/2" H 32 3/16"