

Proudly Distributed By:

**ARMSTRONG
EQUIPMENT
INC.**



MADE IN THE USA

607 PRO

PRODUCT CATALOG



NVE
National Vacuum Equipment

Challenger **Series**
VACUUM PUMPS & BLOWERS

Table Of Contents

3

607 PRO Vacuum Pump

4

607 PRO Hydraulic Drive Pump

5

607 PRO Pump Stand Complete

6

607 PRO Muffler Package

7

607 PRO Max Package

8

607 PRO Top of Frame Mount Packages

9

607 PRO Engine Drive Packages

10

607 Components & Accessories

S
T
N
E
T
N
C
O
N
T
E
N
T
S



607 PRO Heavy Duty Vacuum Pumps Challenger Series

Features

- Lifetime warranty on the housing against cracking
- Ductile iron housing (tough like steel).
- The NVE bi-rotational, four port oil pump is exclusive to our “oil management system” delivering the precise amount of oil required for any job. Easily adjustable to 5-24 oz. per hour.
- Rugged braided stainless steel oil delivery lines
- Vacuum relief boss
- Vane flush port with valve
- Vane wear inspection port
- Integral, easily accessible & cleanable, stainless steel final filter
- Proven crash protection allowing all major components to survive a catastrophic failure
- Remote mount 5 quart see through oil tank for constant oil level monitoring
- Thermometer to monitor exhaust temperature
- Multiple drive options (gearbox, belt, hydraulic, and direct)
- Two year warranty against manufacturer defect
- Designed, built, and supported in the USA



FAN-COOLED OR LIQUID COOLED 607 PRO CHALLENGER | SPECIFICATIONS

AIR FLOW - FREE AIR	380 CFM
*MAXIMUM VACUUM	29" HG
MAXIMUM INTERMITTENT PRESSURE	30 PSI
*OPERATING RANGE - RPM	1250
HP REQUIRED @ VACUUM	25
HP REQUIRED @ 20 PSI	28
PORTING SIZE	3"
SHAFT SIZE (3/8" Key)	1 1/2"

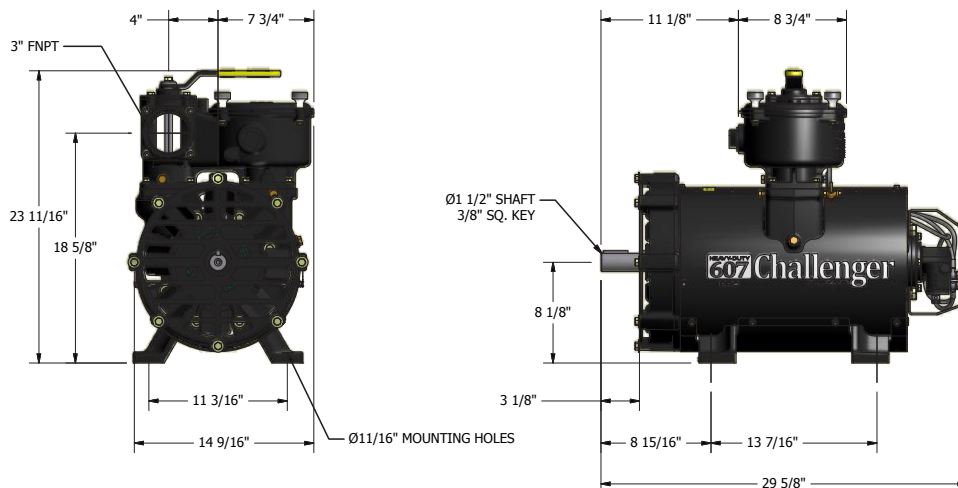

PRODUCT DESCRIPTION

PRODUCT DESCRIPTION	PART NUMBER	WEIGHT
Challenger 607 PRO CW Fan Cooled (Pictured Above)	100-607P-FD	390 lbs
Challenger 607 PRO CCW Fan Cooled	100-607P-FS	390 lbs
Challenger 607 PRO CW Liquid Cooled	100-607P-LD	392 lbs
Challenger 607 PRO CCW Liquid Cooled	100-607P-LS	392 lbs
Challenger 607 PRO Side Valve CW Fan Cooled	100-607AP-FD	390 lbs
Challenger 607 PRO Side Valve CCW Fan Cooled	100-607AP-FS	390 lbs

*The maximum allowable operating vacuum will vary depending on R.P.M., ambient temperature, altitude and time running. The basic principle to keep in mind is - faster R.P.M., higher air temperature and longer run time all equal more heat in pump. When installing an NVE 607 pump we recommend a normal R.P.M. of 1250. Other speeds are ok as long as exhaust gas temperatures read on the supplied thermometer do not exceed 380 degrees F.

607 PRO Hydraulic Motor Drive

Features

- Heavy-duty automatic alignment bracket
- SAE B face 2 and 4 bolt flange
- Coupler set
- Additional fan shroud mounting bracket required for liquid cooled model
- Designed, built, and supported in the USA

607 HYDRAULIC SPECIFICATIONS

Mount = SAE 4 BOLT FLANGE

Shaft = 1.25" with 5/16" Keyway

Side Ports = 1.25" ORB

Cubic Inch Displacement = 5.20IN³/REV

Permco model # M5151A731NMZK20-00(NV)

Max working pressure = 2500 psi

Hydraulic pump should supply 34 gpm @ 2000 psi to turn the 607 at 1250 rpm

Customer must install a case drain and plumb back to tank

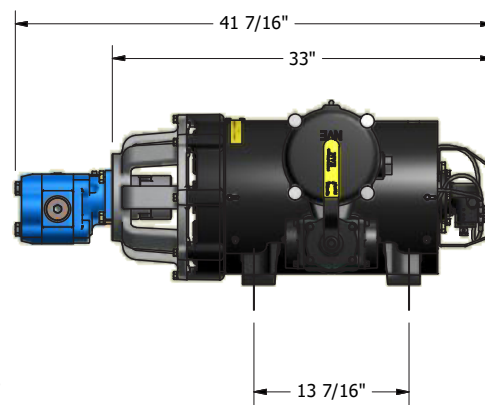
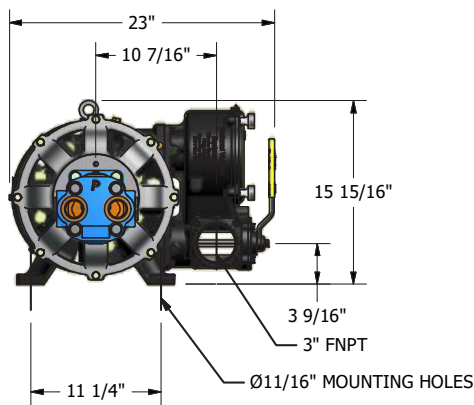

PRODUCT DESCRIPTION

607 PRO Fan Cooled CW W/HYD Drive

PART NUMBER

117-607P-HYD-FD

WEIGHT

464 lbs

607 PRO Fan Cooled CCW W/HYD Drive

117-607P-HYD-FS

464 lbs

607 PRO Liquid Cooled CW W/HYD Drive

117-607P-HYD-LD

483 lbs

607 PRO Liquid Cooled CCW W/HYD Drive

117-607P-HYD-LS

483 lbs

607 PRO Side Valve Fan Cooled CCW W/HYD Drive (Pictured Above)

117-607AP-HYD-AFS

473 lbs

607 PRO Pump Stand Complete Packages

Challenger Series



Features

- Vacuum pump included; specify rotation and cooling type
- Available for fan cooled and liquid cooled models
- 400 series three-shaft gearbox accommodates clockwise and counterclockwise rotation
- Coupler set with shear protection
- Easy-align, adjustable gearbox bracket
- Also available with hydraulic drive
- Designed, built, and supported in the USA

New Gearbox Bracket features include:

- Accelerated installation time
- Allows up to four degree rotation to ease driveline angles
- Slotted mounting plate allowing gearbox to slide further away from the pump

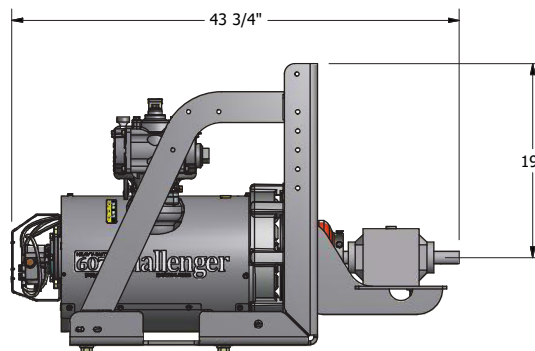
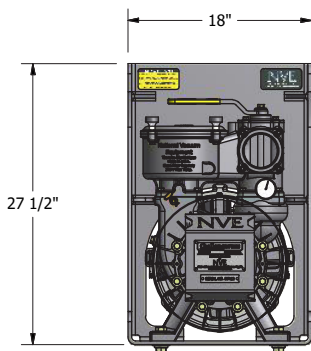
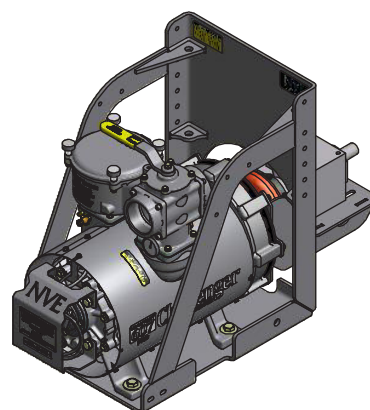
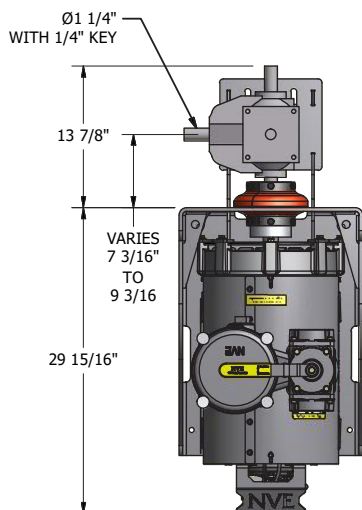

PRODUCT DESCRIPTION	PART NUMBER	WEIGHT
607 PRO Fan Cooled CW Pump Stand Complete (Pictured Above)	117-607P-001-FD	575 lbs
607 PRO Fan Cooled CCW Pump Stand Complete	117-607P-001-FS	575 lbs
607 PRO Liquid Cooled CW Pump Stand Complete	117-607P-001-LD	575 lbs
607 PRO Liquid Cooled CCW Pump Stand Complete	117-607P-001-LS	575 lbs
607 PRO Fan Cooled CCW W/HYD DR Pump Stand Complete	117-607P-001H-FD	638 lbs
607 PRO Fan Cooled CCW W/HYD DR Pump Stand Complete	117-607P-001H-FS	638 lbs
607 PRO Liquid Cooled CW W/HYD DR Pump Stand Complete	117-607P-001H-LD	647 lbs
607 PRO Liquid Cooled CCW W/HYD DR Pump Stand Complete	117-607P-001H-LS	647 lbs

607 PRO Muffler Packages

Features

- Vacuum pump included; specify rotation, cooling type and muffler location (left or right).
- Compact design round oil catch muffler
- Stainless steel mesh filter
- All elbows, fittings and high temp hoses are factory connected
- Right-hand or left-hand muffler location available
- Designed, built, and supported in the USA

New Gearbox Bracket features include:

- Accelerated installation time
- Allows up to four degree rotation to ease driveline angles
- Slotted mounting plate allowing gearbox to slide further away from the pump

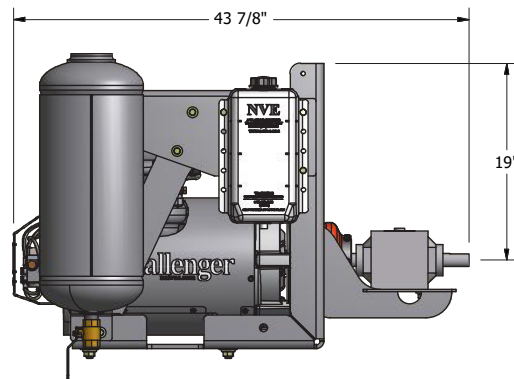
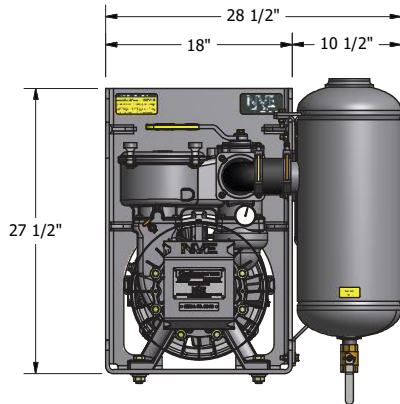
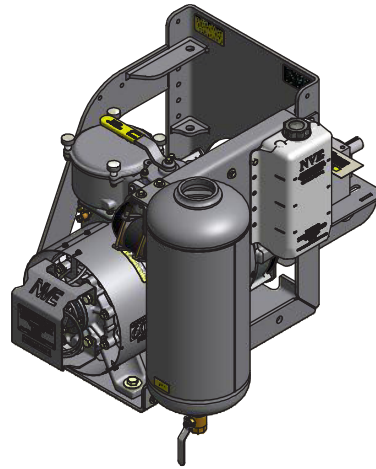
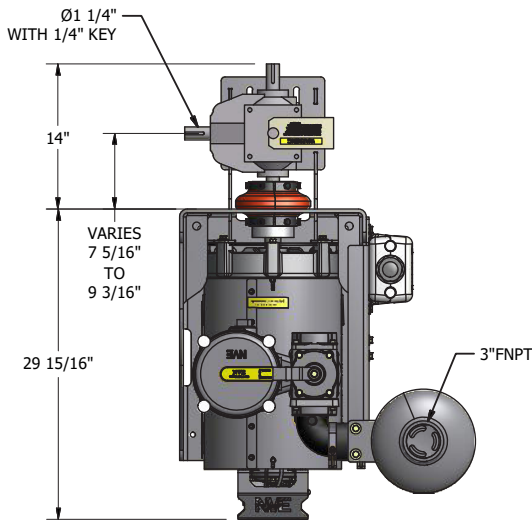

PRODUCT DESCRIPTION	PART NUMBER	WEIGHT
607 PRO Fan Cooled CW Muffler PKG (Pictured Above)	117-607P-MUF-FD	635 lbs
607 PRO Fan Cooled CCW Muffler PKG	117-607P-MUF-FS	635 lbs
607 PRO Liquid Cooled CW Muffler PKG	117-607P-MUF-LD	675 lbs
607 PRO Liquid Cooled CCW Muffler PKG	117-607P-MUF-LS	675 lbs
607 PRO Fan Cooled CW W/Hydraulic Drive Muffler PKG	117-607P-MUF-FDH	684 lbs
607 PRO Fan Cooled CCW W/Hydraulic Drive Muffler PKG	117-607P-MUF-FSH	684 lbs
607 PRO Liquid Cooled CW W/Hydraulic Drive Muffler PKG	117-607P-MUF-LDH	686 lbs
607 PRO Liquid Cooled CCW W/Hydraulic Drive Muffler PKG	117-607P-MUF-LSH	686 lbs



607 PRO Max Packages

Challenger Series

Features

- Vacuum pump included; specify rotation, cooling type and muffler location (left or right).
- 12" round oil catch muffler
- Equipped with an 8" round oil catch muffler for pressure relief
- High efficiency aluminum moisture trap
 - Accessible 6" stainless steel float ball
 - BUNA positive shut-off ball seat
 - 2" lever drain valve
 - Blank intake flange standard (other fittings available)
 - Vacuum/pressure relief valve and gauge
 - All elbows, fittings and high temperature hoses are factory connected.
- Designed, built, and supported in the USA

New Gearbox Bracket features include:

- Accelerated installation time
- Allows up to four degree rotation to ease driveline angles
- Slotted mounting plate allowing gearbox to slide further away from the pump

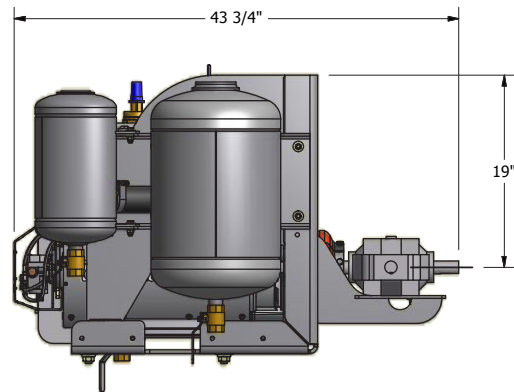
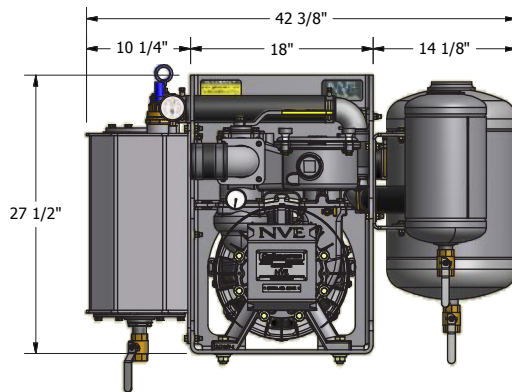
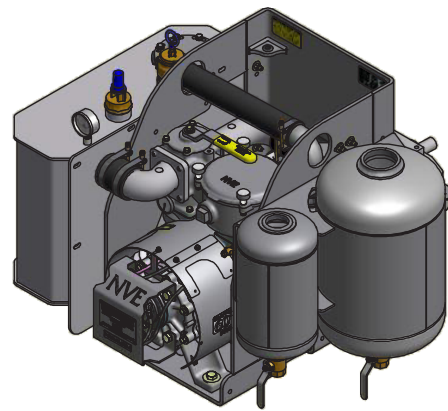
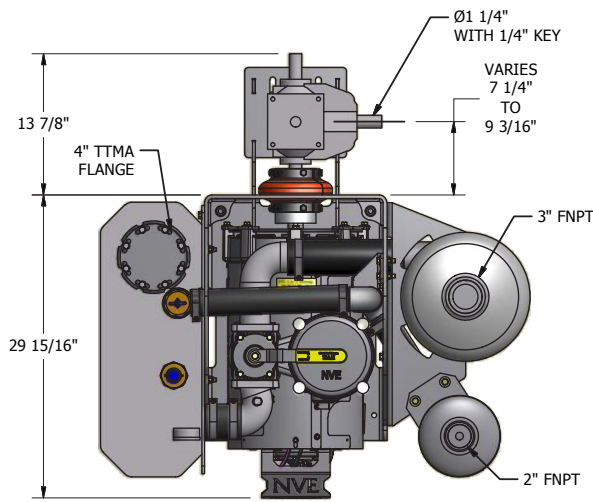

PRODUCT DESCRIPTION	PART NUMBER	WEIGHT
607 PRO Fan Cooled CW MAX PKG	117-607P-MAX-FD	752 lbs
607 PRO Fan Cooled CCW MAX PKG (Pictured Above)	117-607P-MAX-FS	752 lbs
607 PRO Liquid Cooled CW MAX PKG	117-607P-MAX-LD	761 lbs
607 PRO Liquid Cooled CCW MAX PKG	117-607P-MAX-LS	761 lbs
607 PRO Fan Cooled CW W/Hydraulic Drive MAX PKG	117-607P-MAX-FDH	770 lbs
607 PRO Fan Cooled CCW W/Hydraulic Drive MAX PKG	117-607P-MAX-FSH	770 lbs
607 PRO Liquid Cooled CW W/Hydraulic Drive MAX PKG	117-607P-MAX-LDH	779 lbs
607 PRO Liquid Cooled CCW W/Hydraulic Drive MAX PKG	117-607P-MAX-LSH	779 lbs

607 PRO Top of Frame Mount Packages

Features

- Designed for top valve pump
- Mounting bracket that includes oil catch muffler with drain valve and remote oil tank
- Belts and u-bolts available separately
- All elbows, fittings and high temp hoses are factory connected
- Designed, built, and supported in the USA

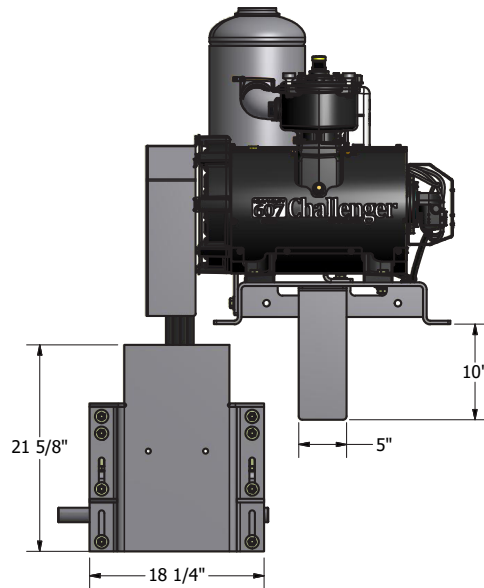
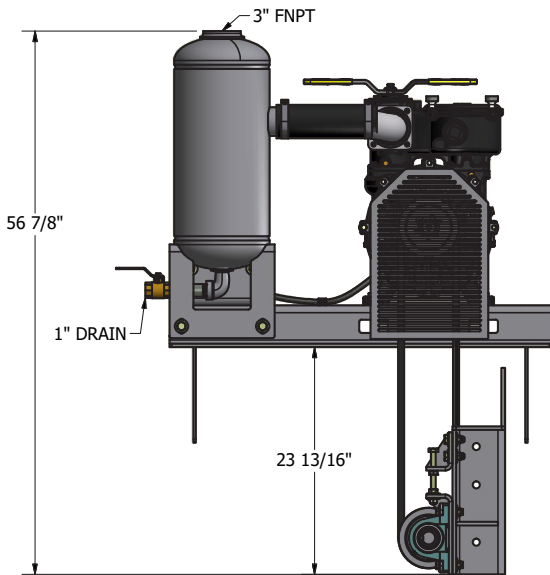
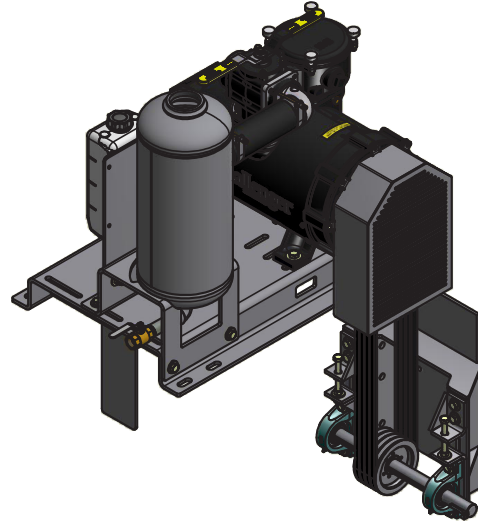
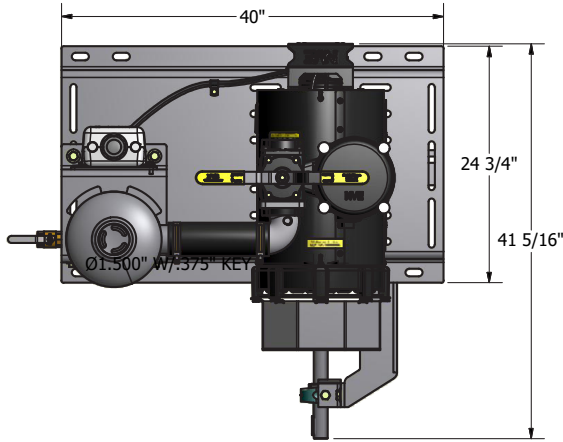

PRODUCT DESCRIPTION

607 PRO Fan Cooled CW Top Mount Belt & Pulley (Pictured Above)

PART NUMBER

117-607P-TM-FD

WEIGHT

791 lbs

607 PRO Fan Cooled CCW Top Mount Belt & Pulley

117-607P-TM-FS

791 lbs

607 PRO Fan Cooled CCW Top Mount w/ HYD Drive

117-607P-TM-FSH

780 lbs

607 PRO Gas Engine Drive Packages

Challenger Series



Gas Engine Features

- 607 Challenger vacuum pump
- Vanguard 37 HP gas engine
- Centrifugal clutch engagement
- Belt and pulley drive
- Fuel tank
- 12 volt high crank capacity battery
- Flush kit
- Oil catch muffler
- Powder coated painted and factory assembled
- Designed, built, and supported in the USA

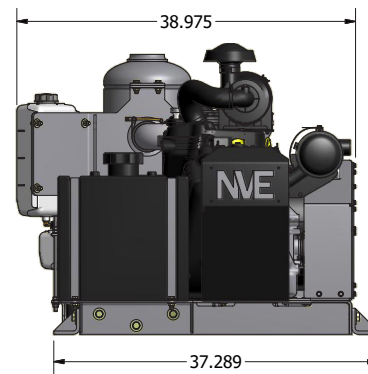
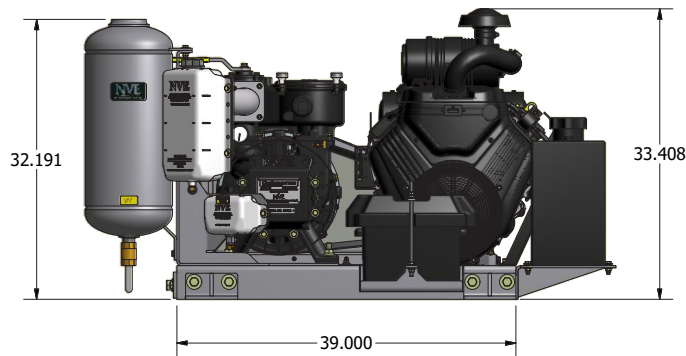
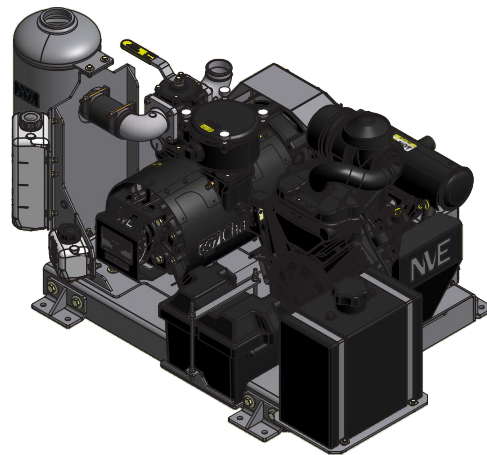
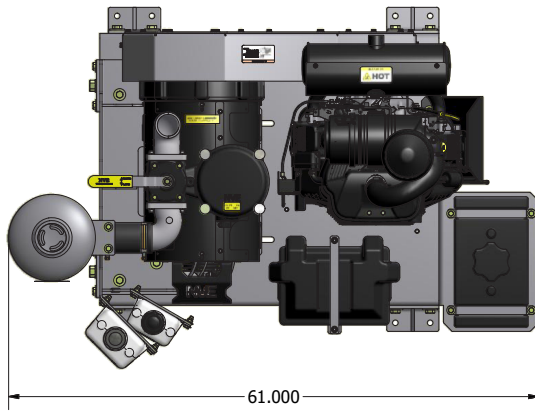

PRODUCT DESCRIPTION

607 Pro Fan Cooled CCW W/37 HP Vanguard Gas Engine

PART NUMBER

117-EDR-607P-3

WEIGHT

912 LBS

607 PRO Diesel Engine Drive Packages

Diesel Engine Features

- Rugged, low profile for belly-mount application
- Diesel engine power unit with electric control
- 23 gallon steel fuel tank
- High efficiency oil catch muffler
- 12 volt high crank capacity battery
- Powder coat painted and factory assembled
- TIER 4 final tested and compliant
- All elbows, fittings and high temperature hoses are factory connected.
- Designed, built, and supported in the USA

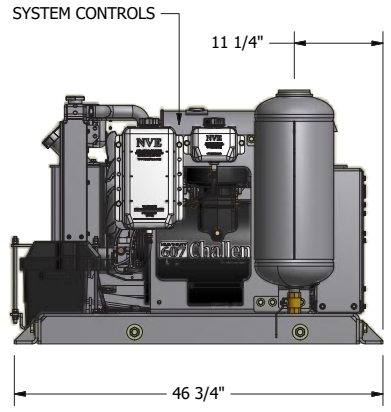
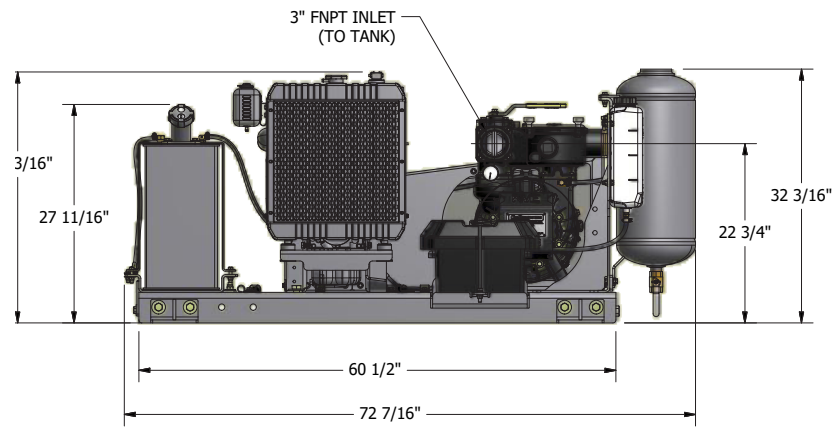
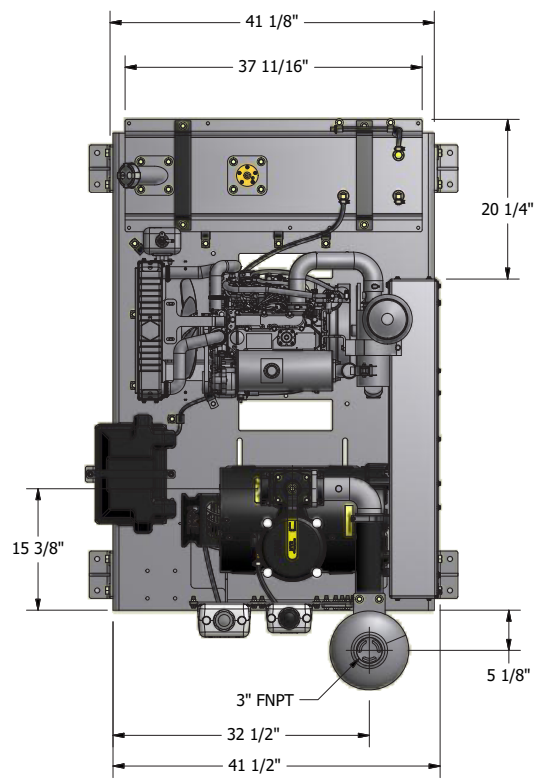
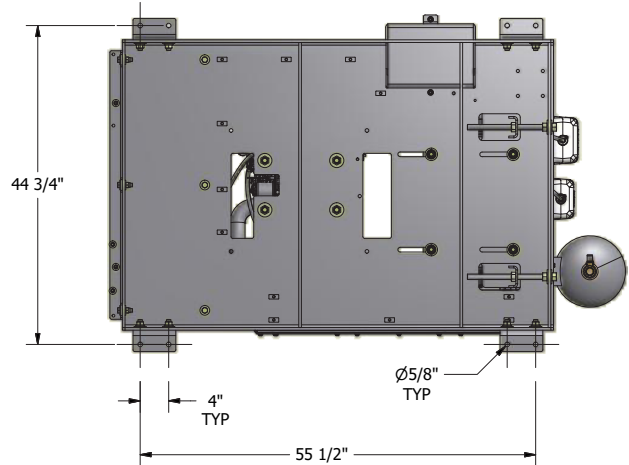

PRODUCT DESCRIPTION	PART NUMBER	WEIGHT
607 Pro Fan Cooled CCW W/23 HP Yanmar Diesel Engine Drive. Will produce up to 10 PSI Only	117-EDR-607P-YAN-1	1480 lbs
607 Pro Fan Cooled CCW W/36.8 HP 3 Cylinder Yanmar Diesel Engine Drive	117-EDR-607P-YAN-2	1999 lbs

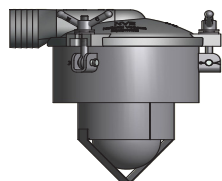

PRODUCT DESCRIPTION	PART NUMBER	WEIGHT
PSO 12" X 6" CARBON BASE, ALU LID 3" HB	200-1206-3HB	47 lbs
PSO 12" X 6" CARBON BASE, CARBON LID 3" NPT	200-1206-3NPT	45 lbs
PSO 12" X 6" SS BASE, STAINLESS STEEL LID 3" NPT	208-1206-3NPT	43 lbs

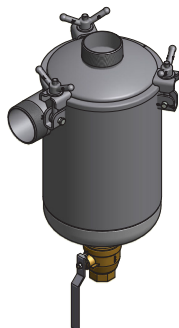

PRODUCT DESCRIPTION	PART NUMBER	WEIGHT
10 Gal Moisture Aluminum 3" HB Lid, 3" NPT	216-100-3HB-A	57 lbs
10 Gal Moisture Trap Carbon 3"	216-100-3NPT-C	91 lbs
10 Gal Moisture Trap SS 3" NPT	216-100-3NPT-S	62 lbs



PRODUCT DESCRIPTION	PART NUMBER	WEIGHT
Manway Carbon 20" X 6" GOL	202-2006	72 lbs



PRODUCT DESCRIPTION	PART NUMBER	WEIGHT
OCM 10" DIA X 17.5" NPT W/ HB	212-100-3NPT-4	65 lbs
OCM 12" DIA 3" NPT Carbon With Bolted Lid	212-120-3NPT	71 lbs

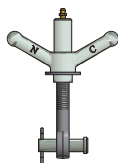

PRODUCT DESCRIPTION	PART NUMBER	WEIGHT
Wingnut, Eyebolt Clevis & Cotter Pin (Qty 6)	284-KIT-C	1.45 lbs
Lubenut, Eyebolt, Clevis & Cotter Pin (Qty 6)	284-KIT-CLN	1.55 lbs



PRODUCT DESCRIPTION	PART NUMBER	WEIGHT
Remote Oil Tank	320-082-001	1.6 lbs
Oil Tank Kit	320-081	2.30 lbs
Oil Tank Cap Black W/Tether	320-083-002	0.10 lbs

607 PRO Components & Accessories



PRODUCT DESCRIPTION	PART NUMBER	WEIGHT
Float Balls 6" SS	414-600-SS	0.5 lbs



PRODUCT DESCRIPTION	PART NUMBER	WEIGHT
Gasket 12" Lid And Neck Buna	286-706-12L	0.65 lbs
Gasket 19.5" Lid Buna	286-706-20L	1 lbs

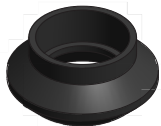

PRODUCT DESCRIPTION	PART NUMBER	WEIGHT
Ball Seat 3" Buna	416-300-B	0.55 lbs
Clamp Worm 3" Ball Seats	416-300-1WC	0.08 lbs

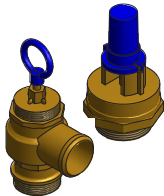

PRODUCT DESCRIPTION	PART NUMBER	WEIGHT
Vacuum Relief 1 1/2" NPT	366-150	1.1 lbs
Pressure Relief 1.50"	364-306-015	1.85 lbs
Pressure Relief 1.25"	364-306-1.25	1.45 lbs
Pressure Relief 2"	364-306-2	2.7 lbs

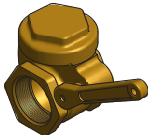

PRODUCT DESCRIPTION	PART NUMBER	WEIGHT
Lever Valve 2"	362-301-2	3.9 lbs
Lever Valve 3"	362-301-3	8.7 lbs
Lever Valve 3" TTMA/NPT	362-301-3T	10 lbs
Lever Valve 4"	362-301-4	12 lbs

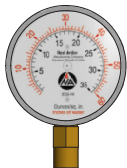

PRODUCT DESCRIPTION	PART NUMBER	WEIGHT
Gauge 2.5" Vac/Pres Liq Bot Conn 1/4" NPT	408-250-LF	0.45 lbs

607 PRO Components & Accessories

Challenger Series



PRODUCT DESCRIPTION	PART NUMBER	WEIGHT
Coupler Hub E20 1 1/4" Bore 1/4" key	424-200-125	7.25 lbs
Coupler Hub E20 1 1/2" Bore 3/8" key	424-200-150	6.9 lbs
Coupler Flex Element E20	424-200-E20	4.15 lbs

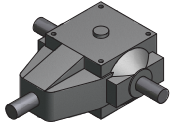

PRODUCT DESCRIPTION	PART NUMBER	WEIGHT
Gearbox 400 Series 1:1 Ratio with 1 1/4" shaft	422-400-1	28.3 lbs

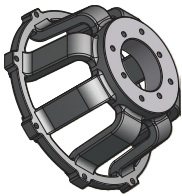

PRODUCT DESCRIPTION	PART NUMBER	WEIGHT
Hydraulic Adapter for 607	120-400-001	17 lbs

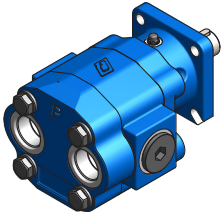

PRODUCT DESCRIPTION	PART NUMBER	WEIGHT
Hydraulic Motor for 607	440-2000-001	48 lbs

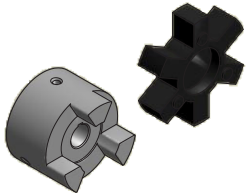

PRODUCT DESCRIPTION	PART NUMBER	WEIGHT
Coupler Flange L150 x 1 1/4" with 1/4" Keyway	424-150-125-HYD	5.10 lbs
Coupler Flange L150 x 1 1/2" with 3/8" Keyway	424-150-150	4.55 lbs
Coupler Spider L150 NBR	424-150-S	.20 lbs



PRODUCT DESCRIPTION	PART NUMBER	WEIGHT
Flange 3" Adjustable Elbow	120-063-007	.50 lbs
O-ring Viton for Elbow	120-064-016	.01 lbs
Elbow 3" 90 Degree Alum. Hose Barb x O-ring	803-063-005	1.00 lbs
Elbow 3" long 90 Degree Alum. Hose Barb x O-ring	803-063-006	1.50 lbs
Elbow 3" 90 Degree Alum. Hose Barb x Hose Barb	803-063-011	.69 lbs

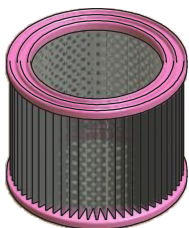

PRODUCT DESCRIPTION	PART NUMBER	WEIGHT
Filter Element Inlet 607/866	120-314-001	.80 lbs

607 PRO Maintenance Items

Features

- The Tool kit makes it easier to rebuild the Challenger vacuum pumps and comes with: Seal driver, Reamer, (2) T-Handles, and (2) shims.
- The NVE Challenger repair kits come with or without bearings and include the seals, gaskets, and vanes required for repair.
- The NVE Challenger flush kits come with all the required items to properly flush your Challenger vacuum pumps.
- The NVE Challenger Pump Oil is ISO 150 though this oil is not required, it is recommended to keep your vacuum pump lubricated properly, particularly in extreme conditions. Sold by the case, six (6) gallons per case.

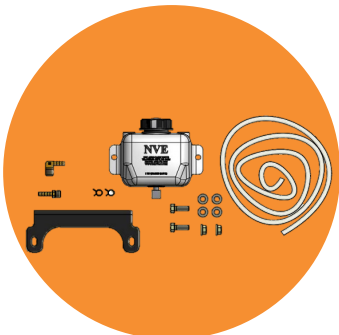

PRODUCT DESCRIPTION	PART NUMBER	WEIGHT
Tool Kit for 367/607	120-0T	4 lbs
Repair Kit 607 PRO	115-607-0	7 lbs
Repair Kit 607 PRO (without bearings)	115-607-0B	4 lbs
Flush Fluid Kit	320-081-002	2 lbs
Oil Vacuum Pump R&O ISO 150/SAE 40 ND - Price per Gallon. 6 Gallons per Case.	150-220-VPOIL-150	7 lbs

Designed. Built. Supported.

Produced in the USA | Distributed World-Wide

Proudly Distributed By:
**ARMSTRONG
EQUIPMENT
INC.**

NVE
National Vacuum Equipment

Challenger Series
VACUUM PUMPS & BLOWERS