

Proudly Distributed By:

**ARMSTRONG  
EQUIPMENT  
INC.**



MADE IN THE USA

# 887 PRO

## PRODUCT CATALOG



**NVE**  
National Vacuum Equipment

**Challenger** **Series**  
VACUUM PUMPS & BLOWERS

# Table Of Contents

---

**3** 887 PRO Vacuum Pump

**4** 887 PRO Pump Stand Complete

**5** 887 PRO Muffler Package

**6** 887 PRO Max Package

**7** 887 PRO Engine Drive

**8** Components & Accessories

S  
T  
N  
E  
T  
N  
C  
O  
N  
T  
E  
N  
T  
S



# 887 PRO Heavy Duty Vacuum Pump Challenger Series

## Features

- Proven crash protection allowing all major components to survive a catastrophic failure
- Four point automatic lubrication system
- Multiple drive options (gearbox and hydraulic)
- Integral, easily accessible, final filter
- Vane flush port with valve
- Vane wear inspection port on housing
- Enhanced axial load capabilities
- Lifetime warranty against cracked housing
- Two year warranty against manufacturer defect
- Vacuum-controlled ballast air cooling system
- Attached ballast silencing system
- Enhanced exhaust check for minimal free air obstruction
- Designed, built, and supported in the USA



## FAN-COOLED 887 PRO CHALLENGER SPECIFICATIONS

AIR FLOW - FREE AIR	532 CFM	
*MAXIMUM VACUUM	28" HG	
*OPERATING RANGE - RPM	1100	1200
HP REQUIRED @ FULL VACUUM	30	33
HP REQUIRED @ 10 PSI	27	31
HP REQUIRED @ 15 PSI	27	36
HP REQUIRED @ 20 PSI	33	42
HP REQUIRED @ 25 PSI	38	48
HP REQUIRED @ 30 PSI	50	54
PORTING SIZE	4"	
SHAFT SIZE (3/8" KEY)	1 3/4"	

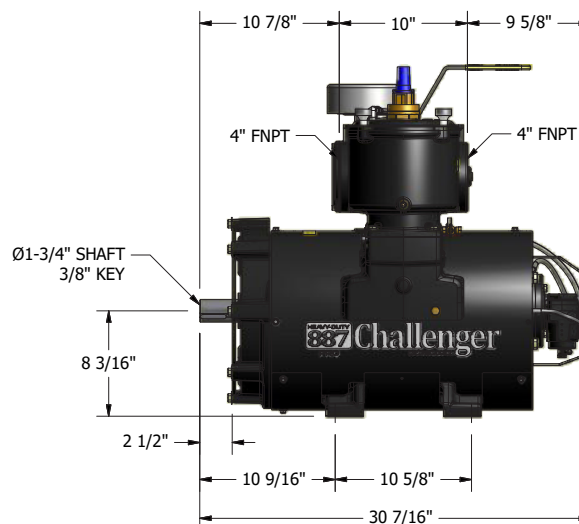
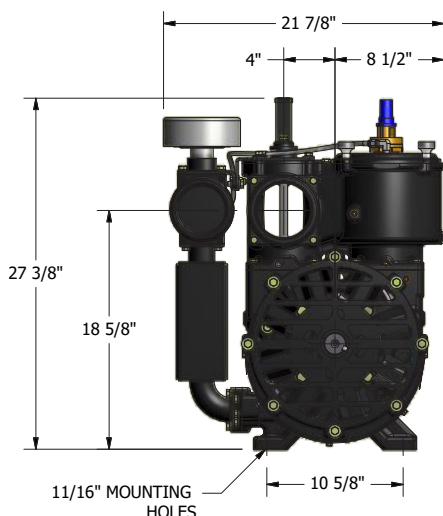

## PRODUCT DESCRIPTION

Challenger 887 PRO CW Fan Cooled (Pictured Above)

## PART NUMBER

103-887P-FD

## WEIGHT

620 lbs

Challenger 887 PRO CCW Fan Cooled

103-887P-FS

620 lbs

\*The maximum allowable operating vacuum will vary depending on R.P.M., ambient temperature, altitude and time running. The basic principle to keep in mind is - faster R.P.M., higher air temperature and longer run time all equal more heat in pump. When installing a NVE 887 pump we recommend a normal R.P.M. of 1100. Other speeds are ok as long as exhaust gas temperatures read on the supplied thermometer do not exceed 380 degrees F.

# 887 PRO Pump Stand Complete Packages

## Features

- Vacuum pump included; specify rotation
- Rugged 3/8" construction, powder coat painted, pump stand
- 400 series three-shaft gearbox accommodates clockwise and counterclockwise rotation
- E20 coupler set with shear protection
- Easy-align, adjustable gearbox bracket
- Also available with hydraulic drive
- Designed, built, and supported in the USA

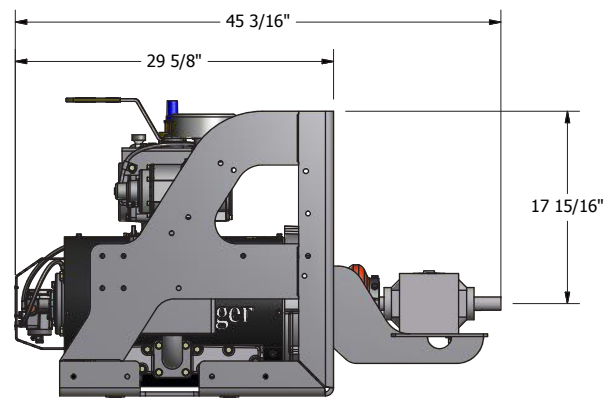
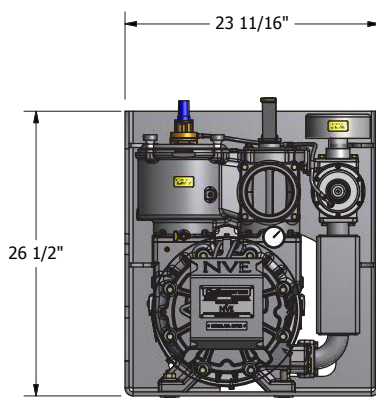
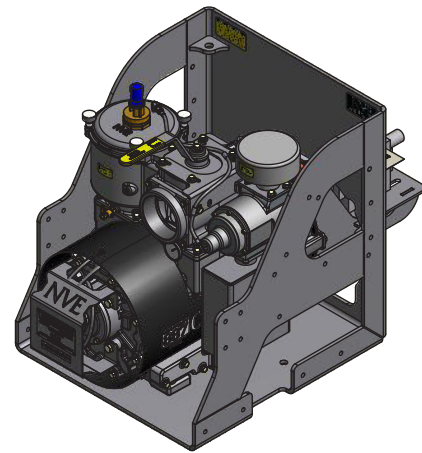
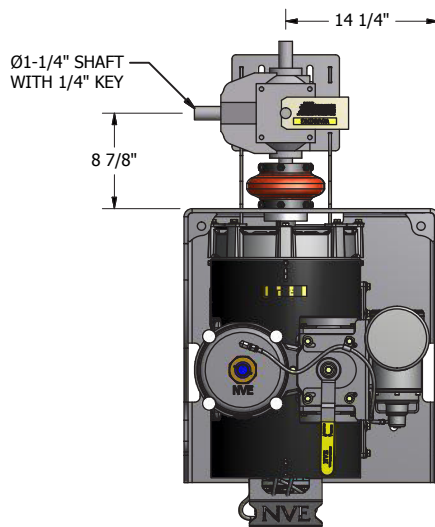

PRODUCT DESCRIPTION	PART NUMBER	WEIGHT
887 PRO Fan Cooled CW Pump Stand Complete W/ Gearbox (Pictured Above)	117-887P-001-FD	841 lbs
887 PRO Fan Cooled CCW Pump Stand Complete W/ Gearbox	117-887P-001-FS	841 lbs
887 Pro Left Hand CW Pump Stand Complete W/Hydraulic Adapter Only	117-887P-001H-FD-A	815 lbs
887 Pro Left Hand CCW Pump Stand Complete W/Hydraulic Adapter Only	117-887P-001H-FS-A	815 lbs
887 Pro Fan Cooled CW W/Hydraulic Adapter Only	117-887P-HYD-FD-A	640 lbs
887 Pro Fan Cooled CCW W/Hydraulic Adapter Only	117-887P-HYD-FS-A	640 lbs

# 887 PRO Muffler Packages

# Challenger Series



## Features

All features included in the Pump Stand Complete plus:

- Vacuum pump included; specify muffler location
- High-efficiency intake exhaust silencer
- 14" round oil catch muffler
- 1" Drain valve
- All elbows, fittings and high temp hoses are factory connected
- Designed, built, and supported in the USA

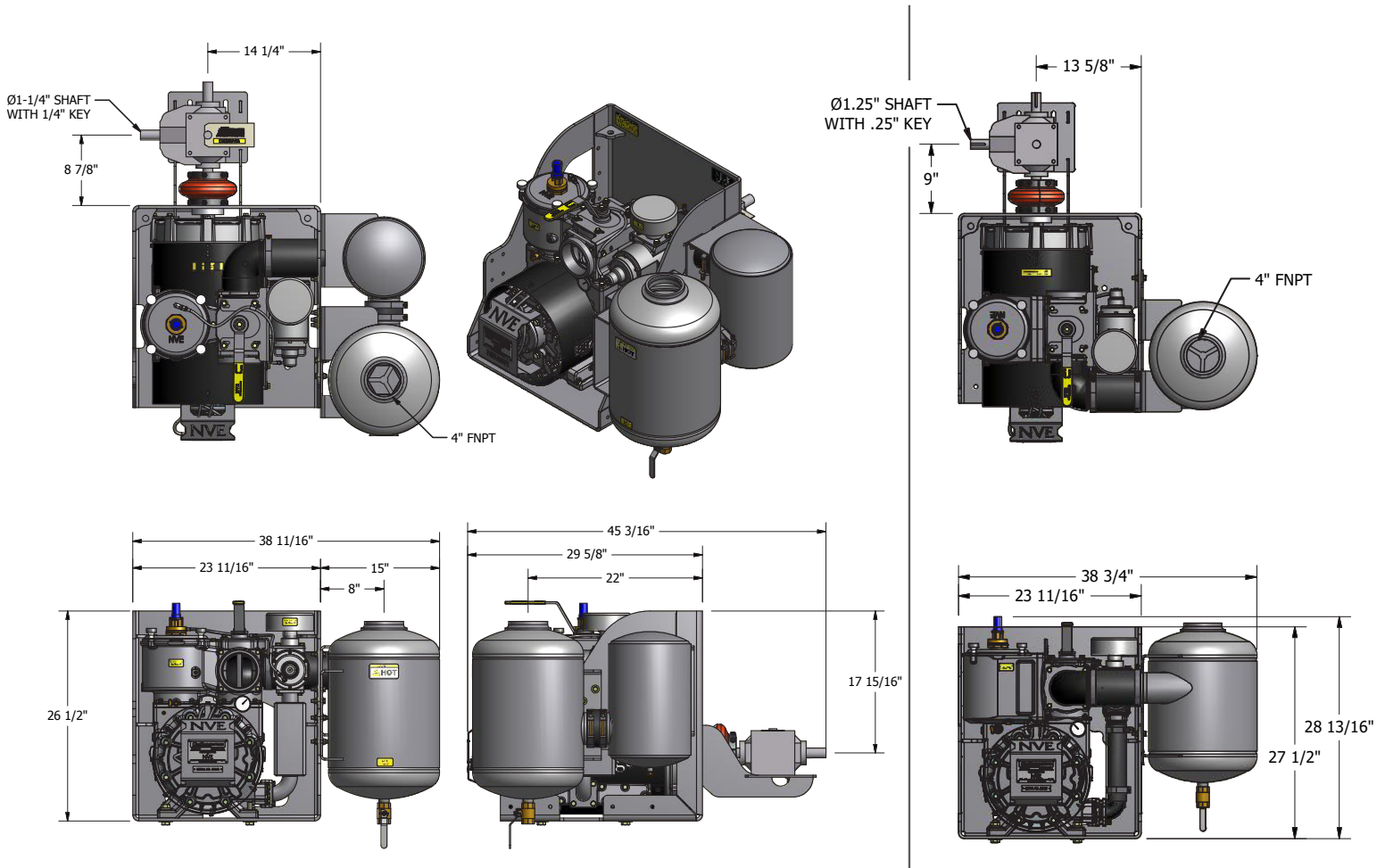

### PRODUCT DESCRIPTION

PRODUCT DESCRIPTION	PART NUMBER	WEIGHT
887 PRO Fan Cooled Right Hand CW Muffler Package (Pictured Above - left)	117-887P-MUF-FD	971 lbs
887 PRO Fan Cooled Left Hand CCW Muffler Package	117-887P-MUF-FS	971 lbs
887 Right Hand CW Muffler Oil Field PKG W/O Silencer (Pictured Above - Right)	117-887-MUF-FD1	980 lbs
887 Pro Right Hand CW Muffler PKG W/Hydraulic Adapter Only	117-887P-MUF-FDH-A	945 lbs
887 Pro Left Hand CCW Muffler PKG W/Hydraulic Adapter Only	117-887P-MUF-FSH-A	945 lbs

# 887 PRO Max Packages

## Features

- Vacuum pump included: specify the muffler location (left or right)
- 14" round oil catch muffler
- High efficiency aluminum moisture trap
- Accessible 6" stainless steel float ball
- BUNA positive shut-off ball seat
- 2" lever drain valve
- Blank intake flange standard (other fittings available)
- Vacuum/pressure relief valve and gauge
- All elbows, fittings and high temp hoses are factory connected
- Right-hand or left-hand muffler location available
- High-efficiency intake exhaust silencer
- Designed, built, and supported in the USA

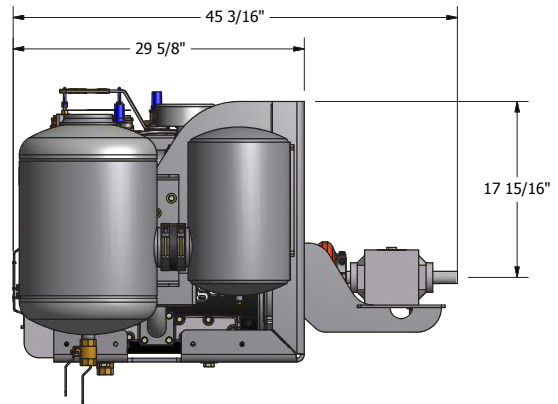
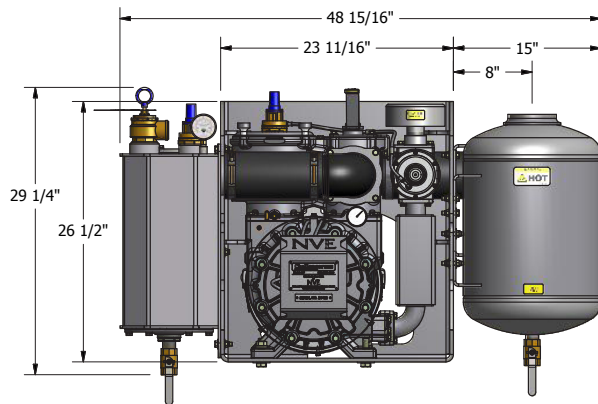
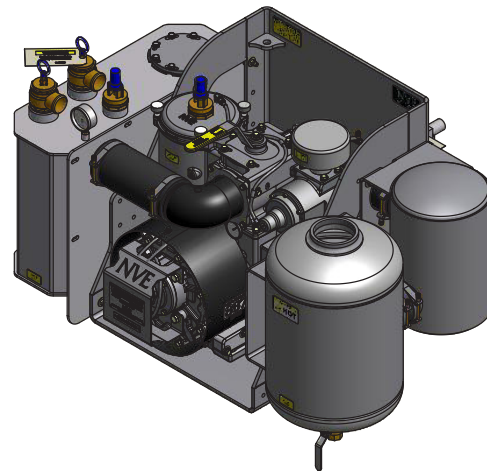
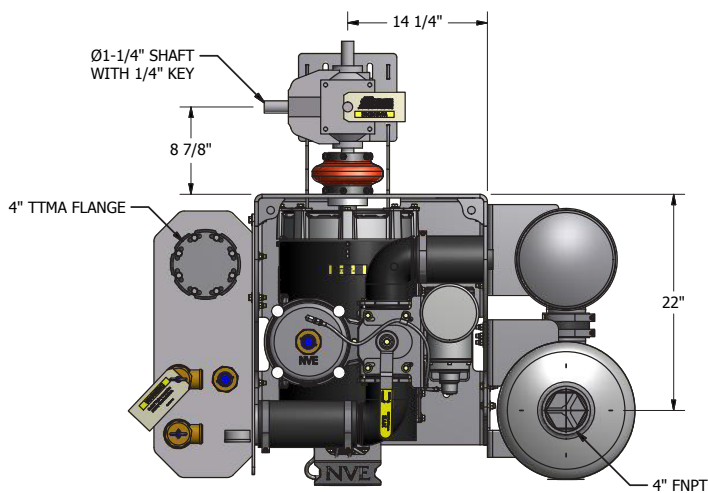

PRODUCT DESCRIPTION	PART NUMBER	WEIGHT
887 PRO Fan Cooled Right Hand CW MAX PKG (Pictured Above)	117-887P-MAX-FD	1044 lbs
887 PRO Fan Cooled Left Hand CCW MAX PKG	117-887P-MAX-FS	1044 lbs

# 887 PRO Engine Drive

# Challenger Series



## Features

- Rugged, low profile for belly-mount application
- Power unit with control panel and tachometer
- 23 gallon steel fuel tank
- High efficiency oil catch muffler
- 12 volt high crank capacity battery
- Powder coat painted and factory assembled
- All elbows, fittings and high temperature hoses are factory connected.
- Designed, built, and supported in the USA

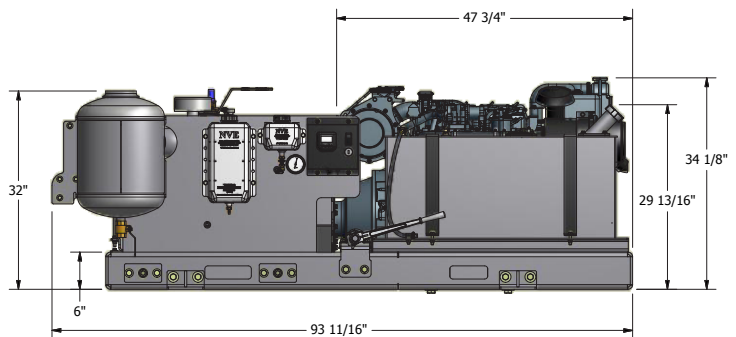
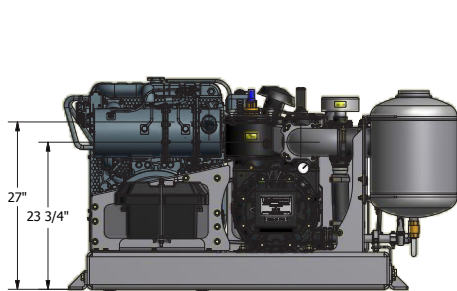
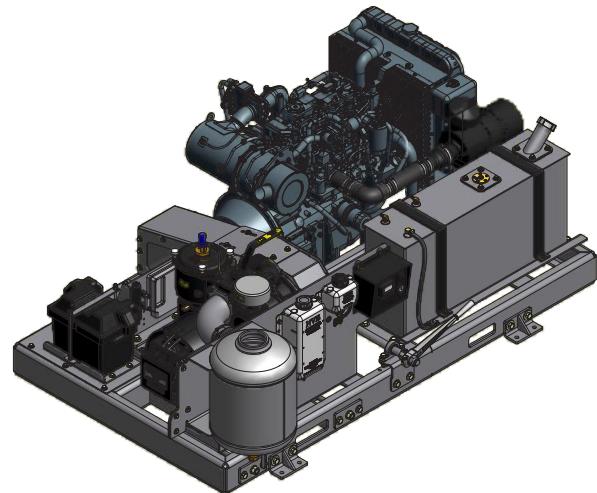
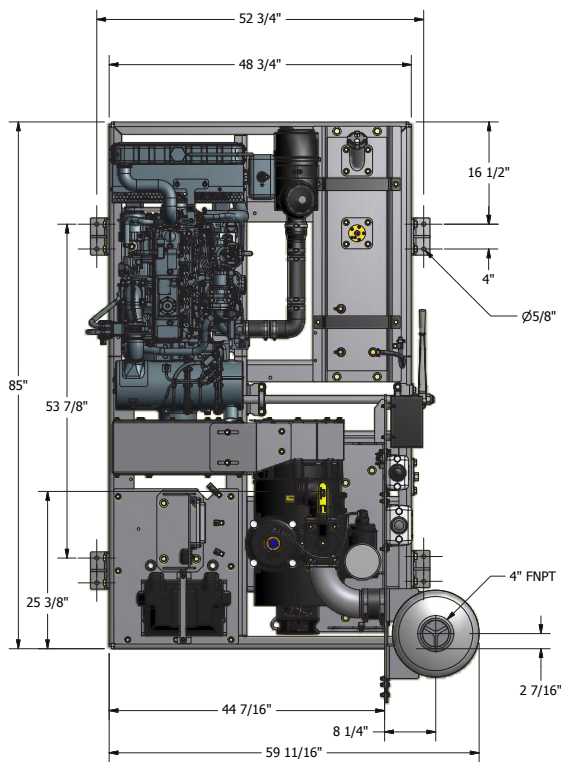

PRODUCT DESCRIPTION	PART NUMBER	WEIGHT
887 PRO Fan Cooled CCW Diesel Engine Drive	117-EDR-887P	2280 lbs
887 PRO Fan Cooled With 69.3 HP Yanmar Engine Drive With Auxiliary Drive	117-EDR-887P-2	2280 lbs

# 887 PRO Components & Accessories



PRODUCT DESCRIPTION	PART NUMBER	WEIGHT
Coupler Hub E20 1 1/4"	424-200-125	7.25 lbs
Coupler Hub E20 1 3/4"	424-200-175	7.25 lbs
Coupler Flex Element E20	424-200-E20	4.15 lbs



PRODUCT DESCRIPTION	PART NUMBER	WEIGHT
Hydraulic Adapter 887	120-400-006	17 lbs
- Easily convert from gear box drive to hydraulic drive with the use of this adapter.		

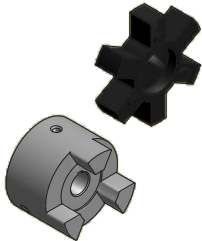

PRODUCT DESCRIPTION	PART NUMBER	WEIGHT
Hydraulic Couplers		
Coupler Flange L150 x 1 1/4" with 1/4" Keyway	424-150-125-HYD	5.10 lbs
Coupler Flange L150 x 1 3/4" with 3/8" Keyway	424-150-175	4.55 lbs
Coupler Spider L150 NBR	424-150-S	.20 lbs
- Lovejoy couplers for use with hydraulic drive option.		



PRODUCT DESCRIPTION	PART NUMBER	WEIGHT
4" Adjustable Elbow	150-063-014	1.50 lbs
O-Ring for Elbow	120-064-012	.01 lbs
Elbow 4" 90 Degree Alum Hose Barb X Hose Barb	803-063-001	2.00 lbs
Elbow 4" 90 Degree Aluminum Hose Barb X Oring	803-063-012	.69 lbs

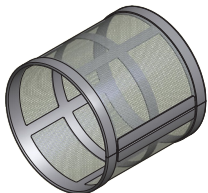

PRODUCT DESCRIPTION	PART NUMBER	WEIGHT
Inkate Filter Assembly PRO	120-314-005	1.25 lbs
Inkate Filter Assembly	120-314-003	1.4 lbs
Filter Element Remote Ballast	120-009-506-5	.30 lbs



# 887 PRO Components & Accessories

## Challenger Series

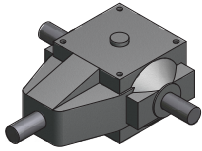

PRODUCT DESCRIPTION	PART NUMBER	WEIGHT
Gearbox	422-400-1	28.30 lbs
- 400 Series 1:1 - Mounting brackets available.		

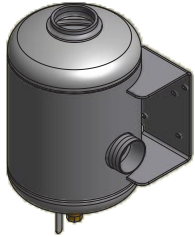

PRODUCT DESCRIPTION	PART NUMBER	WEIGHT
OCM 14" DIA 4" NPT W/HB RH	212-140-4NPT-2	_____
OCM 14" DIA 4" NPT W/RESONATOR R55	212-140-4NPT-4	_____
OCM 14" DIA 4" NPT W/RESONATOR LH	212-140-4NPT-5	_____



PRODUCT DESCRIPTION	PART NUMBER	WEIGHT
Manway 20" X 6" GOL	202-2006	72 lbs

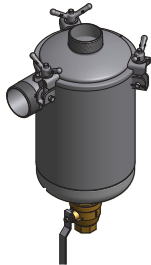

PRODUCT DESCRIPTION	PART NUMBER	WEIGHT
14 Gal Moisture Trap Alu 4" NPT	216-140-4NPT-A	70 lbs
14 Gal Moisture Trap Carbon 4" NPT	216-140-4NPT-C	131 lbs
14 Gal Moisture Trap SS 4" NPT	216-140-4NPT-S	131 lbs

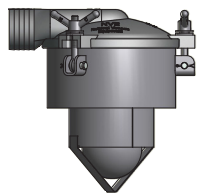

PRODUCT DESCRIPTION	PART NUMBER	WEIGHT
12" Primary Shutoff	200-1206-4HB	47 lbs



PRODUCT DESCRIPTION	PART NUMBER	WEIGHT
Remote Oil Tank	320-082-001	1.6 lbs
Remote Oil Tank Kit	320-081	2.30 lbs
Oil Tank Cap Black W/Tether	320-083-002	0.10 lbs

# 887 PRO Maintenance Items

## Features

- The NVE Challenger repair kits come with or without bearings and include the seals, gaskets, and vanes required for repair.
- The NVE Challenger flush kits come with all the required items to properly flush your Challenger vacuum pumps.
- The NVE Challenger Pump Oil is ISO 150; though this oil is not required, it is recommended to keep your vacuum pump lubricated properly, particularly in extreme conditions. Sold by the case, six (6) gallons per case.

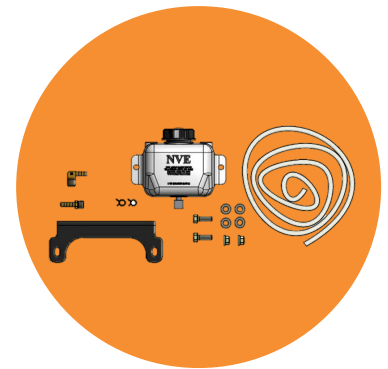

PRODUCT DESCRIPTION	PART NUMBER	WEIGHT
Repair Kit	115-887-0	7 lbs
Repair Kit (without bearings)	115-887-0B	4 lbs
Flush Fluid Kit	320-081-002	2 lbs
Oil Vacuum Pump R&O ISO 150/SAE 40 ND. Price per Gallon. 6 Gallons per Case.	150-220-VPOIL-150	7 lbs



# Designed. Built. Supported.

Produced in the USA | Distributed World-Wide

Proudly Distributed By:  
**ARMSTRONG  
EQUIPMENT  
INC.**

**NVE**  
National Vacuum Equipment

**Challenger** Series  
VACUUM PUMPS & BLOWERS