

DIMENSIONAL SPECIFICATIONS

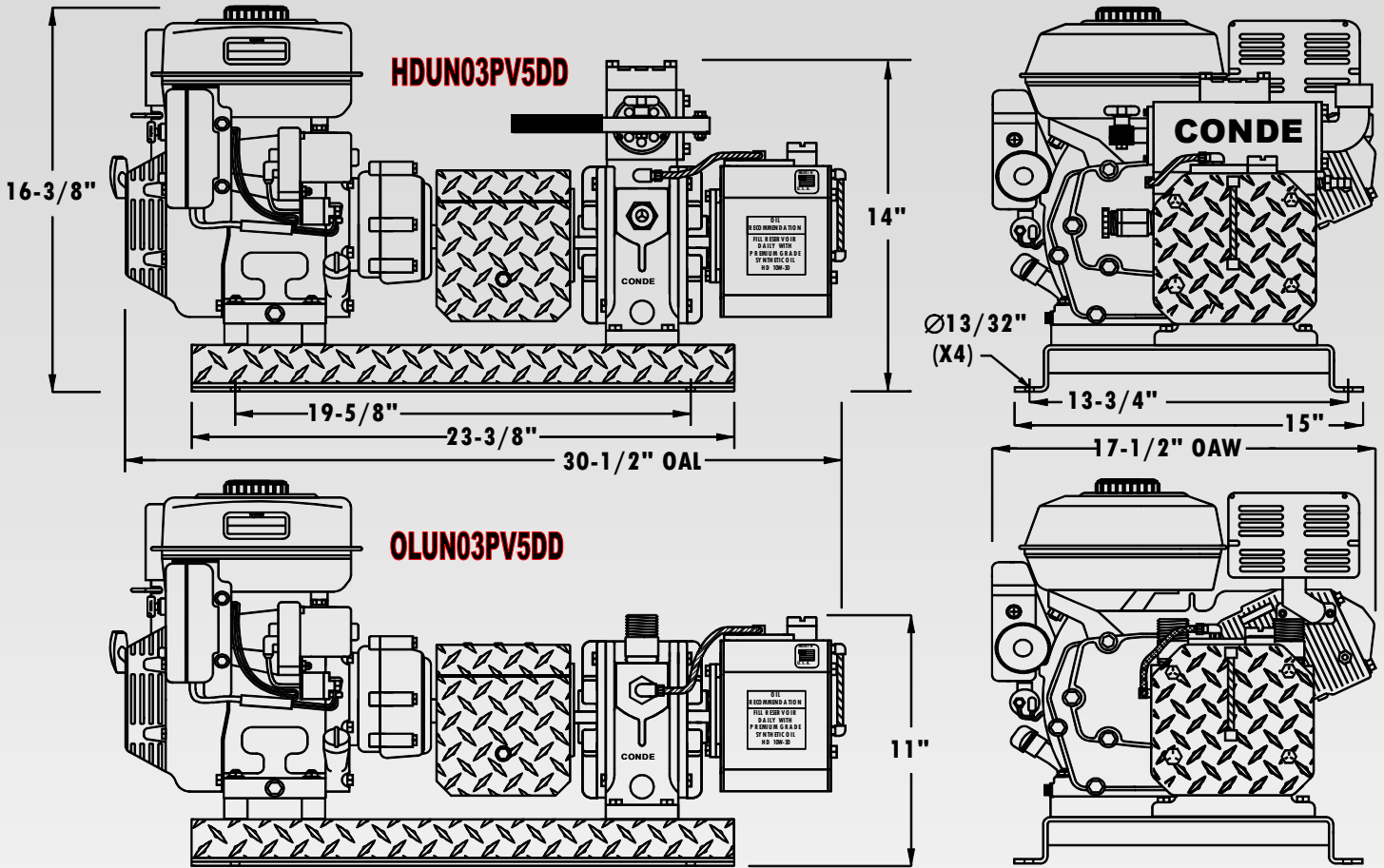

Made In U.S.A.



MOTOR SPECIFICATIONS: HONDA GX160 WITH 2:1 GEARBOX WITH BUILT-IN CLUTCH: THIS STANDARD FEATURE ALLOWS FOR NO LOAD STARTING AND THE ENGINE TO IDLE WITHOUT ENGAGING PUMP.

TECHNICAL SPECIFICATIONS

PERFORMANCE SPECIFICATIONS

PART NO.	OLUN03PV5DD	HDUN03PV5DD
CFM, FREE AIR	35	35
CFM @ 15" HG	17	17
HONDA EL. ST.	YES	YES
DISPLACEMENT	163 cm ³	163 cm ³
VAC. ONLY	YES	NO
VAC. & PRESS.	NO	YES
MAX. VACUUM	27" HG	27" HG
MAX. PRESSURE	15 PSIG	15 PSIG
PUMP OILER	AUTOMATIC	AUTOMATIC
UNIT WEIGHT	125 LBS.	135 LBS.

TANK PULL DOWN TIME - TO 15" HG	
TANK SIZE	PROVAC D.D. GAS UNIT
60 GALLON	12 SECONDS
100 GALLON	20 SECONDS
150 GALLON	30 SECONDS
200 GALLON	40 SECONDS
300 GALLON	60 SECONDS

TANK SYSTEM RECOMMENDATIONS:

Max. Vacuum for Continuous Operation - Vacuum Relief Valve to be set to fully relieve a 20" HG.

Max. Pressure - Pressure Relief Valve Setting NEVER EXCEED - 10 PSI

**Westmoor Ltd.
906 West Hamilton Ave
Sherrill, New York 13461**

Phone: 800-367-0972

Fax: 315-363-0193

Visit us on line @ www.westmoorltd.com