

# HXL4V

## Vacuum / Pressure Pump

Masport have been manufacturing vacuum/pressure pumps for over 100 years, so you can be sure of engineering excellence.

The Masport range of HXL pumps are specifically designed and engineered to meet the needs of hard working pumpers around the world.

To produce our precision pumps, we only use the finest quality components and materials to ensure the durability of your vacuum pump.

Every pump is factory tested before shipping and is backed up by a one year warranty against all manufacturing defects.

With Masport on board you have an efficient and reliable pump backed by the best service and support that has made Masport the #1 choice for pumpers worldwide.

Pump available in Plug & Play and Engine Driven Systems

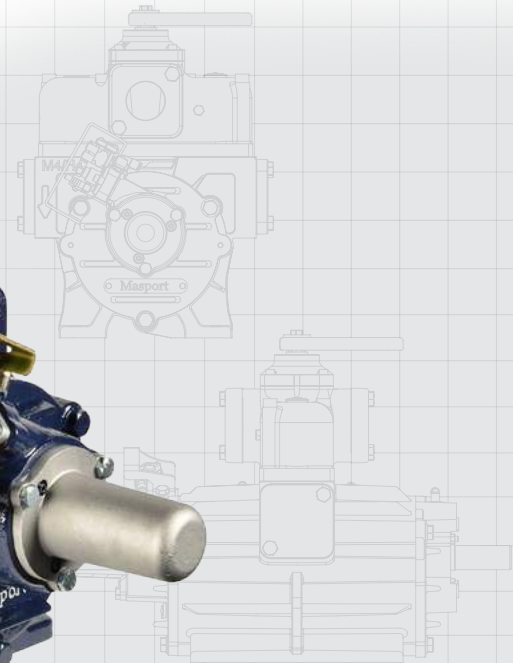
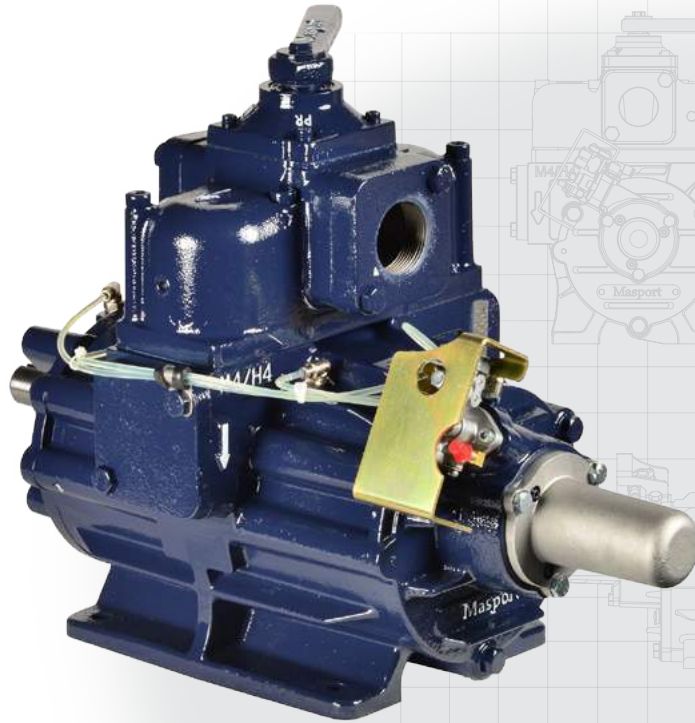

### Masport quality and performance

- ▶ **Achieve minimum 27" Hg** (Intermittent)
- ▶ **Precise machining and assembly**
- ▶ **Heavy duty bearings**
- ▶ **Viton oil seals** for longer service life
- ▶ **Kevlar vanes** are heat stabilized and machined with exacting tolerances for superior ruggedness and durability
- ▶ **Superior pump life**
- ▶ **Mechanical oil pump** with automatic oiling that delivers the right amount of oil at all working levels – no adjustment required
- ▶ **Durable translucent high temperature oil lines** – allows visible flow of oil to the pump
- ▶ **Integral mounting bosses** guarantee precise alignment for hydraulic drive or gearbox mount applications
- ▶ **Tangential rotor design** providing higher airflow efficiency and less vane and cylinder wear
- ▶ **End Thrust Protection** prevents rotor to-endcover contact created by direct PTO drive or misaligned belt driven systems
- ▶ **1½" NPT bolt-on valve flanges** for ease of installation
- ▶ **¼" NPT vane flush port**
- ▶ **Double end shaft** accommodates clockwise or counter-clockwise drive systems
- ▶ **Integral valve** allows the pump to operate in vacuum and pressure mode and reduces plumbing and installation costs
- ▶ **O-Ring Endcovers** eliminates air or oil leakages
- ▶ **Easy to service**
- ▶ **One year performance warranty**



# 165 CFM

Free Air Displacement



# HXL4V

# Vacuum / Pressure Pump

## Performance Data – Vacuum

PUMP R.P.M	DISPLACEMENT C.F.M	S.C.F.M and A.C.F.M @ VACUUM											MAXIMUM VACUUM – “Hg	
		5	10	15	18	20	22	24	25	26	27	CONTINUOUS	INTERMITTENT	
1100	122	SCFM	103	78	57	41	33	23	15	12	7.2	3.7	20	27
		ACFM	121	117	114	103	99	86	75	72	53	37		
1225	137	SCFM	116	88	63	46	37	26	16	14	9.6	4.1	20	27
		ACFM	136	132	127	115	111	97	80	78	71	41		
1400	165	SCFM	132	100	72	53	42	30	19	16	11	4.7	20	27
		ACFM	155	150	145	132	126	112	95	84	81	47		

## Performance Data – Pressure

PUMP R.P.M	DISPLACEMENT C.F.M	S.C.F.M @ P.S.I.G								MAXIMUM PRESSURE – P.S.I.G	
		5	10	15	18	20	25	30	CONTINUOUS	INTERMITTENT	
1100	122	102	97	93	87	82	77	72	20	30	
1225	137	115	109	104	98	92	87	81	20	30	
1400	165	131	125	119	112	105	99	92	20	30	

## Horsepower Required @ “Hg

PUMP R.P.M	VACUUM “Hg				
	5	10	15	20	27
1100	4.4	4.7	4.9	5.4	5.9
1225	4.9	5.2	5.5	6.0	6.6
1400	5.6	5.9	6.3	6.9	7.5

## Horsepower Required @ P.S.I.G

PUMP R.P.M	P.S.I.G				
	5	10	15	20	27
1100	4.9	6.9	8.7	10.7	12.4
1225	5.5	7.7	9.7	11.9	13.8
1400	6.3	8.8	11.0	13.6	15.8

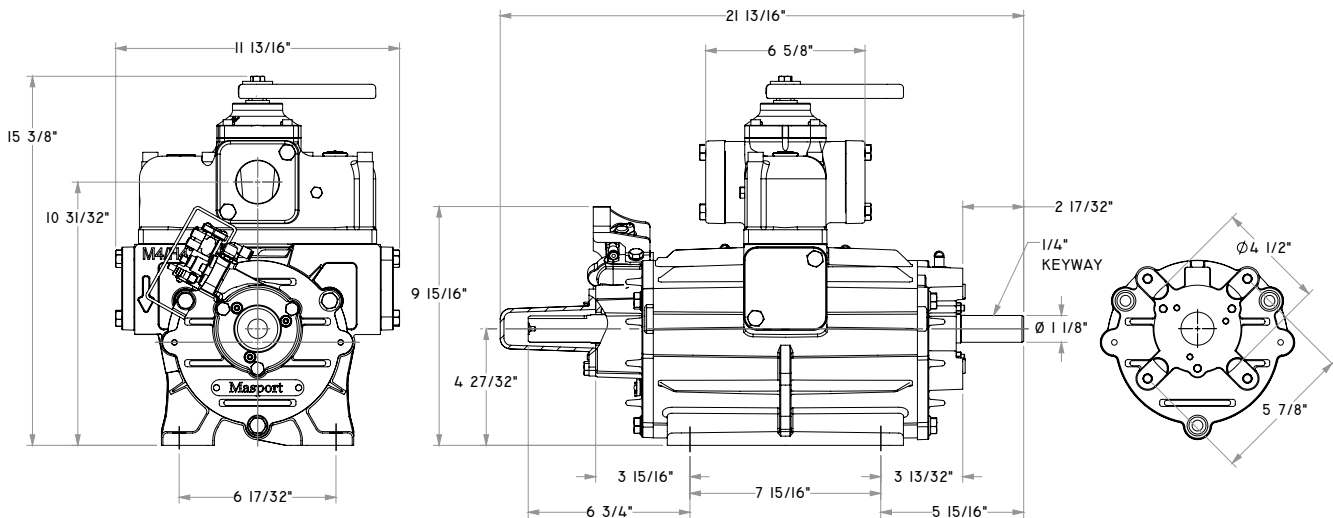

Superior reliability and performance features built into every Masport pump



Integral mounting bosses guarantee alignment with gearbox and hydraulic mount



Automatic adjustment free mechanical oil pump



Oil Reservoir and Flushing Kits available with either plastic or steel reservoirs



Heat stabilized Kevlar vanes machined to exacting tolerances

