

17" Manways | Non-Code

FEATURES:

- Gasket Lid Design
- Wingnut Closure
- 5/8" Square Buna Gasket
- Carbon Steel Lid and Neck



Available with lubenuts
See Accessories
Section E - Fastners

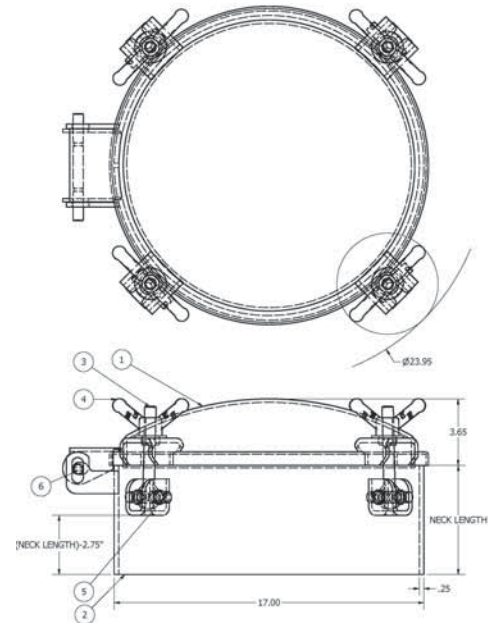

17" Manways - Non-Code | Parts List

PART NUMBER	LID	NECK	WEIGHT
202-1706-C	17" CARBON STEEL	CARBON STEEL 6"	58 LBS
202-1712-C	17" CARBON STEEL	CARBON STEEL 12"	76 LBS

17" Manways - Non-Code | Replacement Parts

ITEM	PART NUMBER	DESCRIPTION
1	226-170-C	17" CARBON LID W/ GASKET
2	CALL NVE	17" X 6" CARBON NECK
	228-1712-C	17" X 12" CARBON NECK
3	284-351-1C	5" NONCODE EYEBOLT
4	284-102-CP	CAST CARBON WINGNUT, PLATED
5	284-400-1C	CARBON CLEVIS PIN, NON-CODE
6	280-703-C	CARBON HINGE PIN
*	286-706-17L	GASKET, 17" LID BUNA
**	280-704-S	COTTER PIN, 1/8X.1.5" SS