

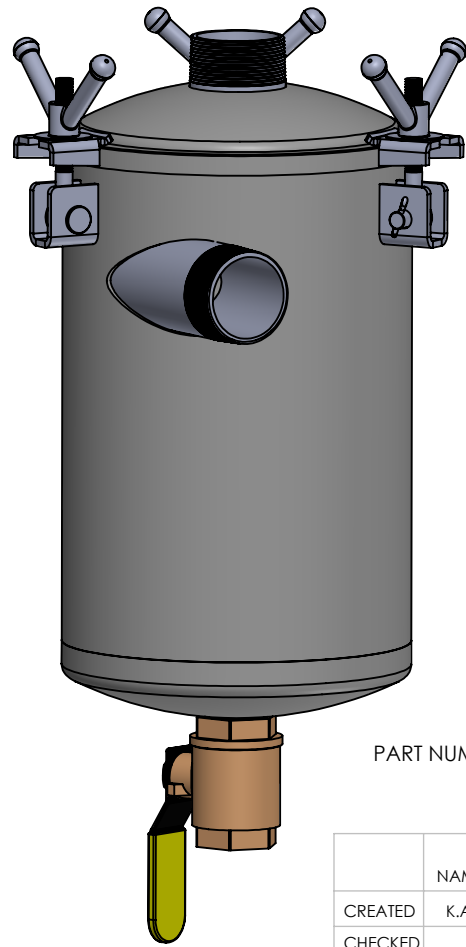

ITEM #	PART #	DESCRIPTION	QTY.
1	WNKIT5	5 PC. WING NUT KIT: WN01, WN02, WN03, WN05, WN06	3
2	P12L-3W3M-CS	Ø12" PRIMARY LID ASSEMBLY, 3" NPT	1
3	S09-A-20	3"- 5" Hose Clamp	1
4	S09-A-12	3" PIPE RUBBER SEAL	1
5	MW12-G	12" ID Square Gasket (.59 x .59)	1
6	S12N-18N3W3M-CS	Ø12" SECONDARY NECK ASSEMBLY, 18" TALL, 3" NPT	1
7	BC6S-13	6" Ball Cage, 13" LONG	1
8	S09-A-04	6" S.S Float Ball	1
9	2NPTBV	2" NPT BALL VALVE	1

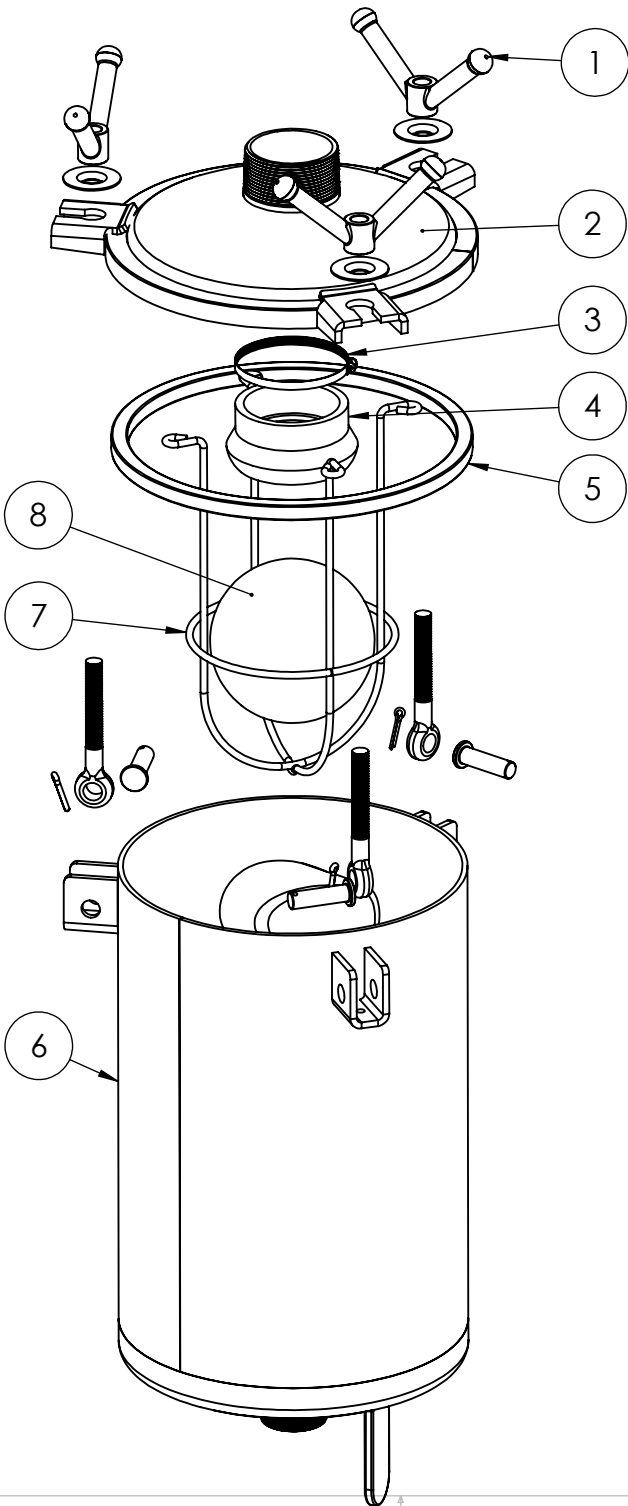

PART NUMBER: S12-18N3W3M-CS

**PROPRIETARY AND CONFIDENTIAL**  
 THE INFORMATION CONTAINED IN THIS DRAWING IS THE SOLE PROPERTY OF FRUITLAND MANUFACTURING. ANY REPRODUCTION IN PART OR AS A WHOLE WITHOUT THE WRITTEN PERMISSION OF FRUITLAND MFG. IS PROHIBITED.

NAME	DATE		324 Leaside Avenue Stoney Creek, Ontario, CANADA L8E 2N7 Phone: (905) 662-6552 Fax: (905) 662 9875	
CREATED	K.A. 10/12/17		TITLE:	12" SECONDARY, 12GAL, 3" NPT
CHECKED		DWG. NO.	S12-18N3W3M-CS	REV P1
UNLESS OTHERWISE SPECIFIED: DIMENSIONS ARE IN INCHES TOLERANCES: FRACTIONAL OR .X = ±.015 .XX = ±.010 .XXX = ±.005		SCALE: 1:7	WEIGHT:--	SHEET 1 OF 2
MATERIAL	--			

5

4

3

2

1

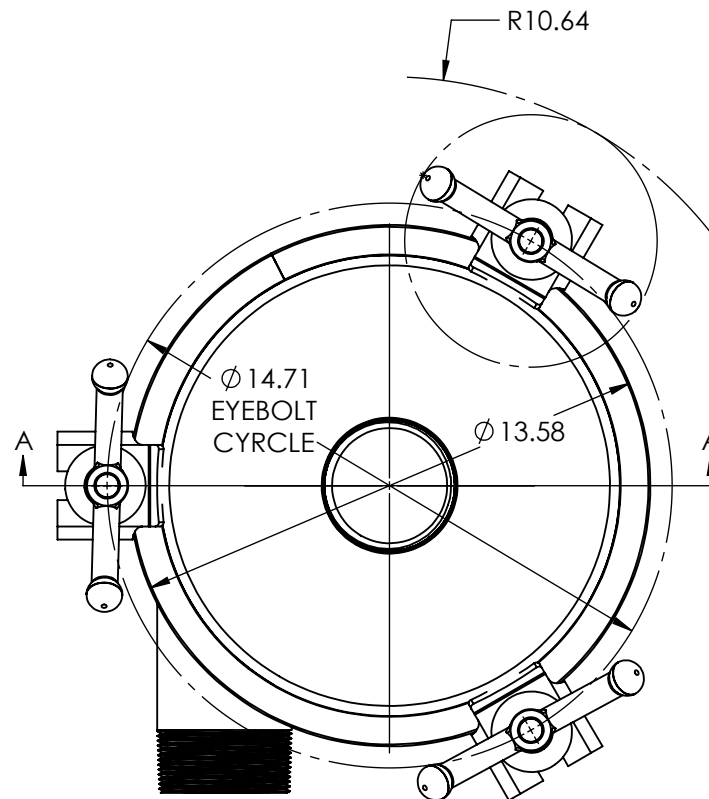
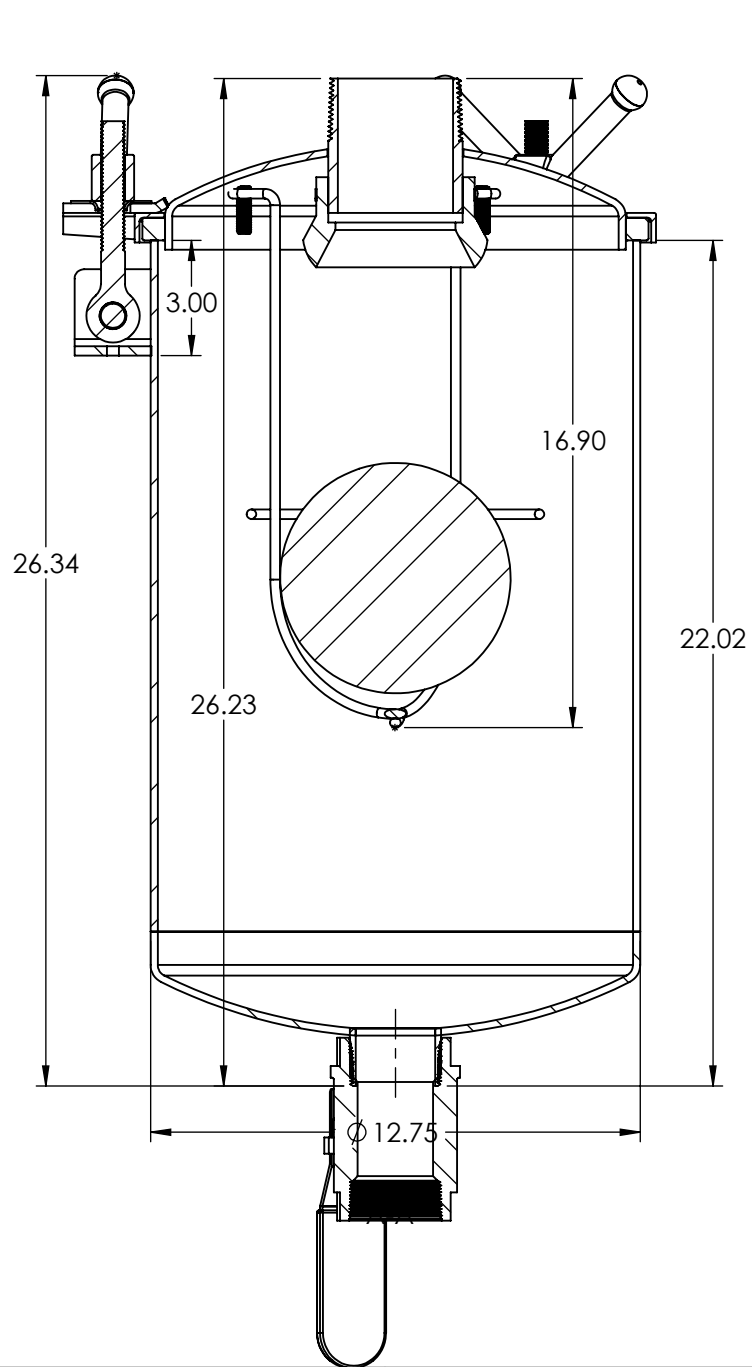

**PROPRIETARY AND CONFIDENTIAL**  
 THE INFORMATION CONTAINED IN THIS DRAWING IS THE SOLE PROPERTY OF **FRUITLAND MANUFACTURING**. ANY REPRODUCTION IN PART OR AS A WHOLE WITHOUT THE WRITTEN PERMISSION OF FRUITLAND MFG. IS PROHIBITED.

	NAME	DATE		324 Leaside Avenue Stoney Creek, Ontario, CANADA L8E 2N7 Phone: (905) 662-6552 Fax: (905) 662 9875	
CREATED	K.A.	10/12/17		TITLE:	12" SECONDARY, 12GAL, 3" NPT
CHECKED			DWG. NO.	S12-18N3W3M-CS	REV P1
UNLESS OTHERWISE SPECIFIED: DIMENSIONS ARE IN INCHES TOLERANCES: FRACTIONAL OR .X = ±.015 .XX = ±.010 .XXX = ±.005			SCALE: 1:5	WEIGHT:--	SHEET 2 OF 2
MATERIAL	--				

5

4

3

2

1