

# FINAL FILTERS

FINAL FILTERS

PART#	DESCRIPTION	L x W x H	WEIGHT
1007-1001	FINAL FILTER WITH 1 1/2" FEMALE NPT, (400 CFM)	12.66 x 10.25 x 13.36	30 LBS
1007-1002	FINAL FILTER WITH 2" FEMALE NPT, (400 CFM)	12.66 x 10.50 x 13.36	31 LBS
1007-1003	FINAL FILTER WITH 3" FEMALE NPT, (400 CFM)	12.41 x 9.58 x 13.36	31 LBS

**\*IMPORT FROM SIDE / EXPORT FROM BOTTOM**



**2 WING NUT STYLE  
EASY ACCESS**

FILTER ELEMENT



55 MESH WIRE STAINLESS  
STEEL CONSTRUCTION  
(For High Heat Applications)

**ADD FINAL FILTER  
PROTECTION TO YOUR  
VACUUM TANK SYSTEM**

1 1/2" Filter - 10.25"  
2" Filter - 10.50"  
3" Filter - 9.50"

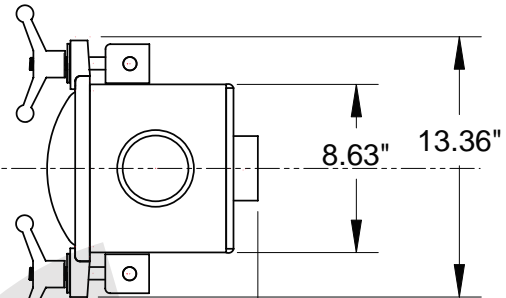
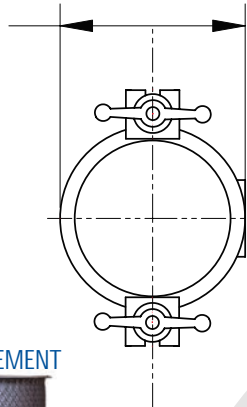

1 1/2" Filter - 12.66"  
2" Filter - 12.66"  
3" Filter - 12.41"

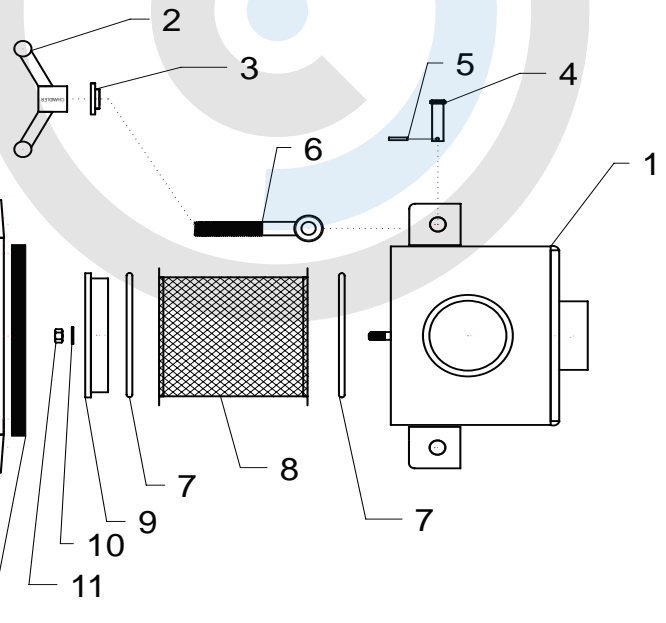

#	PART#	DESCRIPTION
REPLACEMENT PARTS		
1	1007-1015	FILTER BODY 1 1/2"NPT
	1007-1020	FILTER BODY 2"NPT
	1007-1030	FILTER BODY 3"NPT
2	1010-0001	5/8" WING NUT
3	1010-0003	ZINIC MANWAY WASHER
4	1021-0000-P	ZINIC PLATED CLEVIS PIN
5	1021-0000-R	ZINIC PLATED ROLL PIN
6	1021-0000-B	5/8" X 5" EYEBOLT
7	1021-0021	O'RING
8	1545002900	S.STEEL ELEMENT 55 MESH
9	1007-1016	FILTER ELEMENT CAP
10	1000-0110	3/8" WASHER
11	1000-0168	3/8" NUT
12	1007-1010	8" LID ASSY.(GSK-LID TYPE)
13	1007-1011	8" LID GASKET (GASK-LID TYPE)