

MASPORT
BUILT TO WORK AS HARD AS YOU DO

OWNER/OPERATOR MANUAL HD1, HD2 & HD3

LEGACY MODELS: H1, HXL2 & HXL3



Warning! This Manual includes important product safety information. Misuse of this product may result in severe injury or death. Read this manual carefully before attempting to use this product.



Masport Incorporated
6801 Cornhusker Hwy
Lincoln, NE 68507

www.masportpump.com
Email: cs@masportpump.com

Phone: 800-228-4510
Hours: M-F | 8am-5pm (CST)

Record of Purchase

Serial Number: _____

Date Purchased: _____

Please carefully read the installation, operation, and maintenance instructions for your Masport Vacuum/Pressure Pump. These are provided to assist you and they assume users have a basic level of mechanical competence.

If you have any questions about the correct installation, operation, or maintenance procedures, please ask Masport.

Contents

Masport Standard Limited Warranty	4
Introduction	8
Intended Use	9
Installation	9
Recommended System Components	11
Drive Systems	13
Rotation of the Pump	13
Pump Speeds and Power Requirements	14
Vacuum Relief Valve	14
Pressure Relief Valve	15
Pump Lubrication	16
Flushing Information	19
Maintenance and Important Operating Tips	21
Troubleshooting	22
Pump Service	24
Exploded Views	38

Masport Standard Limited Warranty

Limited Warranty:

THE LIMITED WARRANTY SET FORTH IN THIS SECTION (THIS "LIMITED WARRANTY") GIVES YOU SPECIFIC LEGAL RIGHTS AND YOU MAY ALSO HAVE OTHER RIGHTS, WHICH VARY FROM STATE TO STATE.

SUBJECT TO THE TERMS SET FORTH HEREIN, MASPORT HEREBY WARRANTS THAT DURING THE WARRANTY PERIOD (DEFINED BELOW) THE PRODUCTS PURCHASED FROM MASPORT ON THE SITE OR OTHERWISE WILL, IN NORMAL AND INTENDED USE AND SERVICE, BE FREE FROM DEFECTS IN MATERIAL AND WORKMANSHIP.

OUR RESPONSIBILITY FOR DEFECTIVE PRODUCTS IS LIMITED TO REPAIR OR REPLACEMENT AS SET FORTH IN THIS LIMITED WARRANTY. NEITHER ANY PERFORMANCE OR OTHER CONDUCT, NOR ANY ORAL OR WRITTEN INFORMATION, STATEMENT, OR ADVICE PROVIDED BY US OR ANY OF OUR SUPPLIERS, AGENTS, OR EMPLOYEES WILL CREATE A WARRANTY, OR IN ANY WAY INCREASE THE SCOPE OR DURATION OF THIS LIMITED WARRANTY.

Who May Use This Limited Warranty?

This Limited Warranty extends only to the Customer and the original end-user (if such original end-user is someone other than the Customer). As such, this Limited Warranty does not extend to any subsequent or other owner, transferee, or beneficiary of the Products.

What Does This Limited Warranty Cover?

During the Warranty Period, this Limited Warranty covers defects in materials and workmanship in Products purchased from Masport on the Site or otherwise.

What Is The Period Of Coverage Under This Limited Warranty?

This Limited Warranty starts on the date set forth on the Order Confirmation to Customer for the warranted Products and lasts for twelve (12) months thereafter (the "Warranty Period").

How Do You Obtain Warranty Service?

The Customer or original end-user must provide notice of covered defects in writing to Masport during the Warranty Period and within thirty (30) calendar days following the Customer's or original end-user's discovery of such defect (the "Notice Period").

What Does This Limited Warranty Not Cover?

Notwithstanding anything herein to the contrary, this Limited Warranty does not cover any of the following, each of which are hereby expressly excluded therefrom:

- A. Defects that are not discovered during the Warranty Period;
- B. Defects that are not reported to Masport in writing within the Notice Period;
- C. Usual and customary deterioration or wear resulting from normal use, service, and exposure;
- D. Any Products that are transported outside of the United States;
- E. Any shortages or discrepancies, all of which shall be exclusively governed by the Inspection and Claims section of these Terms set forth above;

- F. Any claims for loss, damage, cost, or expense caused by any delay or damage in shipment or delivery damage, all of which shall be exclusively governed by the terms set forth in the Product Delivery section above;
- G. Shipping or other costs incurred to return the Products to Masport for warranty inspection;
- H. Damage to persons or property other than the Products, or for any incidental, consequential, or special damages.
- I. Any defect and/or any loss, damage, cost, or expense incurred by Customer, original end-user, or any third party to the extent the same arise out of, relate to or result, in whole or in part, from any one or more of the following:
 - 1. Theft, vandalism, accident, war, insurrection, fire or other casualty;
 - 2. Defects or damage caused by the Customer, original end-user, or any third party;
 - 3. Exposure to corrosive, chemical, ash, smoke, fumes, or the like;
 - 4. Any Products that have been altered, modified, or repaired by Customer, original end-user, or any third party without Masport's prior written consent;
 - 5. Failure to perform any preventative maintenance;
 - 6. Storage;
 - 7. Combination or use of the Products with any products, materials, processes, systems, or other matter not provided or authorized in writing by Masport;
 - 8. External causes such as accidents, abuse, or other actions or events beyond our reasonable control; or
 - 9. Any misuse of the products, including any use of the Products not in conformity with product manuals or contrary to product warnings.

Resolution of Warranty Claims:

In the event Masport is notified of a warranty claim in conformity with the notice requirements set forth above, Masport shall, with the full cooperation of Customer and/or original end-user (which shall include, without limitation, return of the Products for warranty inspection if requested by Masport), immediately undertake an investigation of such claim. To the extent Masport determines, in its sole discretion, that the warranty claim is covered by this Limited Warranty, Masport will, as Customer and original end-user's sole and exclusive remedy and at Masport's option, either:

- A. Ship replacement products to Customer or original end-user; or
- B. Ship repaired product(s) to Customer or original end-user.

Masport shall not be responsible to Customer or original end-user for the cost of dismantling any defective Products or installing replacement Products, all of which shall be and for all purposes remain the sole responsibility of Customer and original end-user.

Customer's Responsibility to Masport Concerning Original End-Users:

Customer warrants and represents that if it resells any Products or incorporates any Products into its own merchandise for the purpose of sale, Customer will:

- A. In all instances causes such purchaser to be bound by, and agree to, this Limited Warranty as set forth herein, including all terms and limitations thereof;
- B. Properly affix all warning labels to all Products;
- C. Provide the applicable Masport product manuals to such purchasers.

Disclaimer of Implied Warranties:

CUSTOMER EXPRESSLY ACKNOWLEDGES AND AGREES THAT: (I) THIS LIMITED WARRANTY SET FORTH HEREIN IS AN INTEGRAL PART OF THE AGREEMENT PURSUANT TO WHICH THE PRODUCTS WERE PURCHASED; (II) CUSTOMER (FOR ITSELF AND ON BEHALF OF THE ORIGINAL END-USER, IF APPLICABLE) HAS ACCEPTED THIS LIMITED WARRANTY AS THE SOLE AND EXCLUSIVE WARRANTY GIVEN BY MASPORT TO CUSTOMER AND ORIGINAL END-USER WITH RESPECT TO THE PRODUCTS; AND (III) THIS LIMITED WARRANTY IS REFLECTED IN THE PURCHASE PRICE FOR THE PRODUCTS. MASPORT MAKES NO OTHER REPRESENTATIONS OR WARRANTIES OF ANY KIND, WHETHER EXPRESS OR IMPLIED, BY OPERATION OF LAW OR OTHERWISE, WITH RESPECT TO ANY PRODUCTS, GOODS, OR SERVICES SOLD OR PROVIDED TO THE CUSTOMER PURSUANT TO THE AGREEMENT OR OTHERWISE, INCLUDING WITHOUT LIMITATION ANY REPRESENTATION OR WARRANTY OF MERCHANTABILITY OR FITNESS FOR ANY PARTICULAR PURPOSE OR USE, ALL OF WHICH ARE EXPRESSLY HEREBY DISCLAIMED.

Limitation on Liabilities and Damages:

THE REMEDIES DESCRIBED ABOVE ARE YOUR SOLE AND EXCLUSIVE REMEDIES AND OUR ENTIRE OBLIGATION AND LIABILITY FOR ANY BREACH OF THIS LIMITED WARRANTY OR THE AGREEMENT. TO THE FULLEST EXTENT PERMITTED BY LAW, IN NO EVENT SHALL MASPORT BE LIABLE FOR ANY SPECIAL, INDIRECT, PUNITIVE, COVER, INCIDENTAL OR CONSEQUENTIAL DAMAGES, HOWEVER CAUSED, WHETHER IN CONTRACT OR TORT OR UNDER ANY OTHER THEORY OF LIABILITY, INCLUDING WITHOUT LIMITATION, LOSS OF REVENUE, ANTICIPATED PROFITS, BUSINESS OR SALES, ANY LOSS OF GOODWILL OR REPUTATION, OR THE COSTS OF SUBSTITUTE GOODS OR PRODUCTS, EVEN IF MASPORT OR AN AUTHORIZED REPRESENTATIVE THEREOF HAS BEEN ADVISED OF THE POSSIBILITY OF SUCH DAMAGES. IN ADDITION, TO THE EXTENT PERMITTED BY APPLICABLE LAW, WE (INCLUDING OUR PARENT, SUBSIDIARIES, AND AFFILIATES, AND OUR AND THEIR OFFICERS, DIRECTORS, MANAGERS, AGENTS, AND EMPLOYEES) ARE NOT LIABLE, AND YOU AGREE NOT TO HOLD US RESPONSIBLE, FOR ANY DAMAGES OR LOSSES RESULTING DIRECTLY OR INDIRECTLY FROM:

- A. YOUR USE OF OR YOUR INABILITY TO USE OUR PRODUCTS;
- B. SUSPENSION OR OTHER ACTION TAKEN WITH RESPECT TO THE PRODUCTS OR BREACH OF ANY OF THESE TERMS; OR
- C. YOUR NEED TO MODIFY PRACTICES, CONTENT OR BEHAVIOR OR YOUR LOSS OF OR INABILITY TO DO BUSINESS, AS A RESULT OF CHANGES TO THE AGREEMENT.

NOTWITHSTANDING ANYTHING CONTAINED HEREIN TO THE CONTRARY, IN NO EVENT SHALL THE TOTAL LIABILITY OF MASPORT TO YOU OR ANY THIRD PARTY FOR ALL DAMAGES, LOSSES, AND CAUSES OF ACTION (WHETHER IN CONTRACT OR TORT, INCLUDING, BUT NOT LIMITED TO, NEGLIGENCE, PRODUCT LIABILITY OR OTHERWISE) ARISING FROM THE AGREEMENT OR YOUR PURCHASE OR USE OF THE PRODUCTS EXCEED, IN THE AGGREGATE, THE LISTED PURCHASE PRICE PAID BY YOU FOR THE PRODUCTS YOU PURCHASED PURSUANT TO THE TERMS HEREUNDER.

Some jurisdictions do not allow the exclusion of damages, so such exclusions may not apply to you. The limitation of liability set forth above shall only apply to the extent permitted by applicable law.

Limitation on time to file claims:

TO THE FULLEST EXTENT PERMITTED BY LAW, ANY CAUSE OF ACTION OR CLAIM YOU MAY HAVE ARISING OUT OF OR RELATING TO THE AGREEMENT OR YOUR USE OF OUR PRODUCTS MUST BE COMMENCED WITHIN SIX (6) MONTHS AFTER THE CAUSE OF ACTION ACCRUES, OTHERWISE, SUCH CAUSE OF ACTION OR CLAIM IS PERMANENTLY BARRED.

Indemnification:

You agree to indemnify and hold harmless Masport, its affiliated companies and their respective officers, directors, employees, managers, agents, successors, and assigns ("Indemnified Parties") from and against any claim or demand (including reasonable attorneys' and experts' fees and costs) made by any party due to or arising out of your (a) breach of the Agreement, (b) improper use of the Products, (c) breach of any law or the rights of a third party, or (d) failure to strictly comply with your obligations to Masport concerning original end-users or any representations made by you to such original end-user. Masport shall promptly notify you in writing of any threatened or actual claim or demand and reasonably cooperate with you to facilitate the settlement or defence thereof. You shall have sole control of the defence or settlement of any claim or demand, provided that Masport, at our option and expense, may participate and appear on an equal footing with you. You shall not settle any claim or demand without the written consent of the Indemnified Parties, with such consent not to be unreasonably withheld or delayed.

Introduction

Congratulations on your purchase of a Masport Pump. We are delighted you have chosen to join the community of satisfied customers using Masport equipment in daily professional operations.

Our products are backed by over 100 years of engineering excellence and are specifically designed and engineered to meet the needs of hard-working pumpers around the world.

Our expert product development, manufacturing and distribution teams work to rigorous quality standards and a strict testing regime. To produce our precision pumps, we only use the finest quality components and materials to ensure the durability of your vacuum pump. Every vacuum pump is factory tested before shipping and is backed up with a one-year warranty against all manufacturing defects. This system ensures you receive a quality product.

This manual provides all the information you will need to run your pump correctly to ensure a long and efficient service life. If you have any questions, please contact your local Masport representative or Masport directly.

Our History:

Masport designs, manufactures, and assembles vacuum pumps, blowers and associated products. The company was established by Harold Mason and Reuben Porter under the name City Engineering in Auckland, New Zealand, in 1910. Within a couple of years, the Mason and Porter business, or Masport as the company later became known, was manufacturing vacuum pumps and a range of engines to power all types of farm equipment.

Masport first looked to international markets with trial exports of vacuum pumps to the United States in 1956 – and has never looked back since. In 1991 the ownership of Masport’s vacuum pump division was transferred to Skellerup Holdings – an iconic New Zealand Company which also celebrated its centenary in 2010.

With Masport on board you have an efficient and reliable pump backed by the best service and support that has made Masport the #1 choice for pumpers worldwide.

Over 100 Years of Engineering Excellence



Intended Use

Masport vacuum/pressure pumps are intended to be used for loading and unloading of liquid material. These pumps are commonly used for liquid waste transport, septic tank cleaning, oil field water trucks, car wash or grease trap cleaning and many other industrial applications.



WARNING! Masport pumps must not be used to move flammable or highly caustic material. Use of this pump for moving hazardous material may result in machinery failure, bodily injury or even death.

Installation

Whatever the configuration of the vacuum system on your truck or trailer, all components and plumbing must be of adequate size, or the system will not operate correctly.

The minimum I.D diameter plumbing for each of the pumps should meet the specifications detailed in the table below:

Pump	Minimum Pipe I.D
HD1 & H1	1"
HD2 & HXL2	1 ½"
HD3 & HXL3	1 ½"



WARNING! Do not use plumbing and components smaller than the required I.D. or the airflow will be restricted, and the pump may overheat and be damaged.

Ensure all pipes, hoses and fittings are thoroughly cleaned before fitting and free of any kind of dirt or debris. Any solid particles ingested by the vacuum pump may cause irreparable damage that will result in loss of performance and increased operating noise. Some form of pipe sealant should be used on all thread connections to prevent leaks.

Four-Way Valve:

For pumps fitted with a valve, the four-way valve is used to change the pump operation from vacuum to pressure or pressure to vacuum by rotating the handle through 90 degrees. The centre position is neutral.

Either valve port can be plumbed to the inlet or the exhaust using the correct I.D pipe.

The valve handle is mounted on a four-sided shaft. It can be repositioned through four different positions to suit the operator's needs and access requirements.

Indicator Washer:

All pumps that are fitted with a valve are supplied with an Indicator Washer. The Indicator washer secures the valve handle and shows the direction to turn the handle for pressure or vacuum operation. The Indicator Washer is reversible allowing the washer to be orientated to your specific setup and plumbing configuration.



Indicator Washer Side

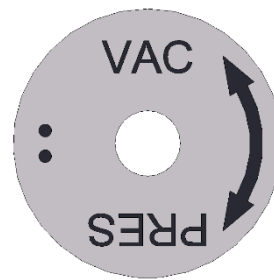

Indicator Washer Side



WARNING! The installation of the Handle Indicator Washer is the responsibility of the installer. Incorrect orientation of the Handle Indicator Washer may result in unexpected vacuum or pressure that may result in machinery failure, bodily injury or even death.

Hose:

Any hose used in the system is to be rated for at least 28"Hg vacuum and 25 PSI pressure, and withstand air/oil temperatures up to 300 F. Hot-tar and asphalt hose is designed for use in this type of environment.

Recommended System Components

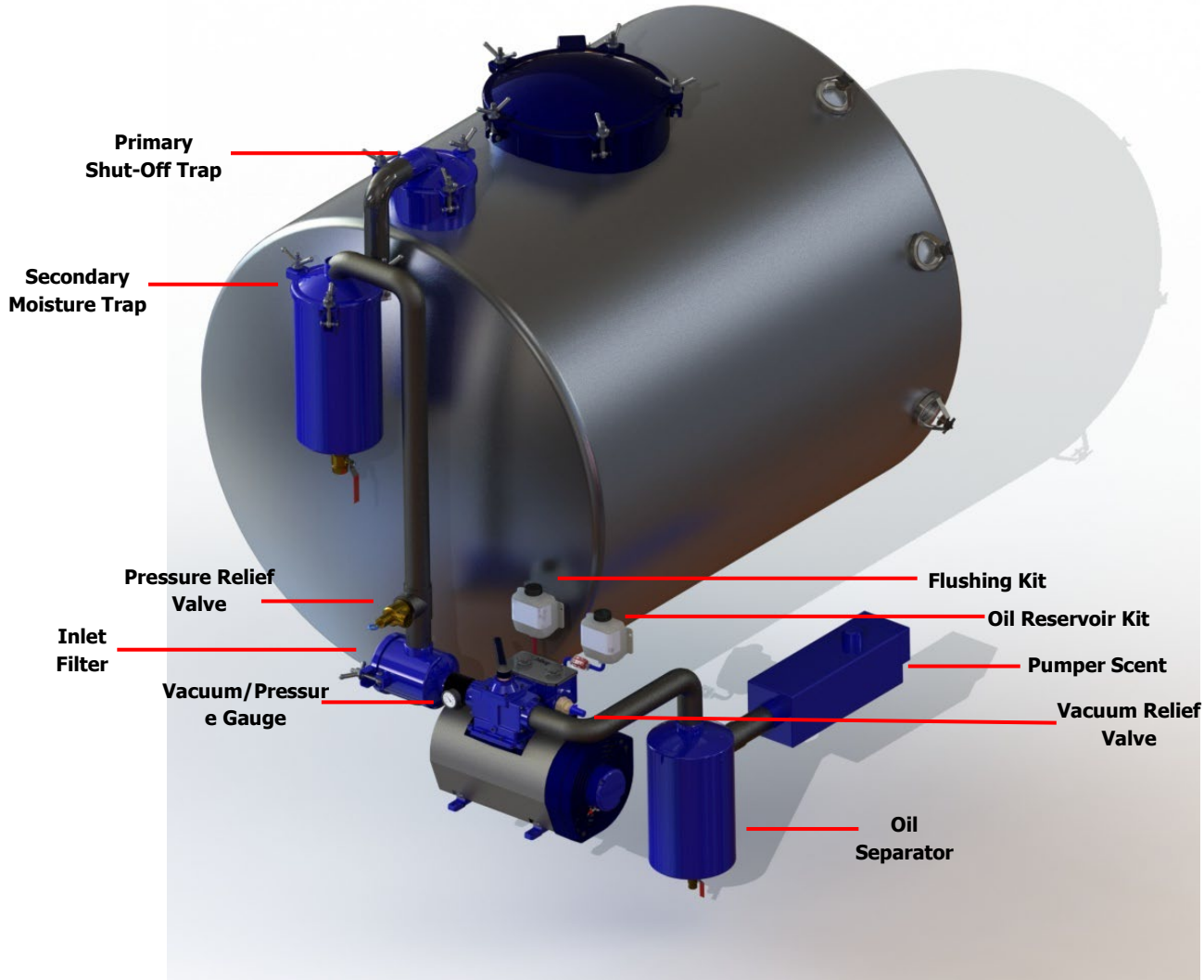

Primary Shut-Off Trap:

A float ball shut-off that prevents liquid in the tank from overflowing into the system and entering the vacuum pump. Liquid entering the vacuum pump can damage or destroy the vacuum pump.

Secondary Moisture Trap (Scrubber):

Removes liquid still in the air stream after passing through the Primary Trap. The Scrubber should be drained after every load.

Inlet Filter:

Prevents small particulate matter from entering the pump. This filter should be checked and cleaned or replaced regularly.

Vacuum/Pressure Gauge:

Liquid filled gauges provide accurate measurements that allow monitoring of the vacuum pump under both vacuum and pressure operating modes.

Vacuum Relief Valve:

Governs the operating vacuum level. It should be installed at the pump so that if a liquid level trap is activated or a hose collapses the pump is prevented from overheating.

Pressure Relief Valve:

Regulates the amount of pressure the system is exposed to. It should be located between the Scrubber and the vacuum pump on the clean side of the system and be of sufficient flow capacity to fully relieve the vacuum pump.



WARNING! Operating your system without a properly installed pressure relief valve in good working order could lead to equipment damage or catastrophic failure resulting in severe injury.

Oil Separator (Muffler):

Removes oil from the pump exhaust. It is equipped with a ball valve at the bottom and should be drained at least daily.

Oil Reservoir Kit:

The oil reservoir kit supplies filtered lubricating oil to the pump.

Flushing Kit:

The flushing kit supplies a cleaning fluid to the vacuum pump. This extends the vacuum pumps life by preventing the build-up of carry-over from liquid level traps causing contamination.

Pumper Scent (Optional):

The Pumper Scent box removes odor from the exhaust. Its use is recommended in environmentally sensitive areas.



Scan or Click the QR Code to Purchase
Recommended Tank Components

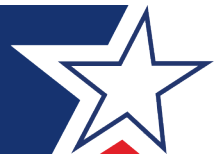

Drive Systems

Whichever drive system is chosen (PTO, Hydraulic, Engine Drive or Pulley and Belts), ensure it is adequately sized to suit the pump requirements. The chosen motor needs to satisfy the horsepower and RPM requirements of the pump.

Alignment is important. If the vacuum pump is not aligned properly, it will cause excessive wear on the drive element and pump bearings.

 **WARNING!** Ensure that all moving parts are properly guarded.

Rotation of the Pump

The HD1 pump is a single shaft pump. There is an arrow cast into the pump housing indicating proper pump rotation.

The HD2 and HD3 pumps can be driven from either of the two shafts to accommodate a clockwise or a counter-clockwise drive system. There is an arrow printed onto the into the pump housing and/or the indicating the proper pump rotation.

For both setups ensure that the drive system direction corresponds to the direction shown on the pump.

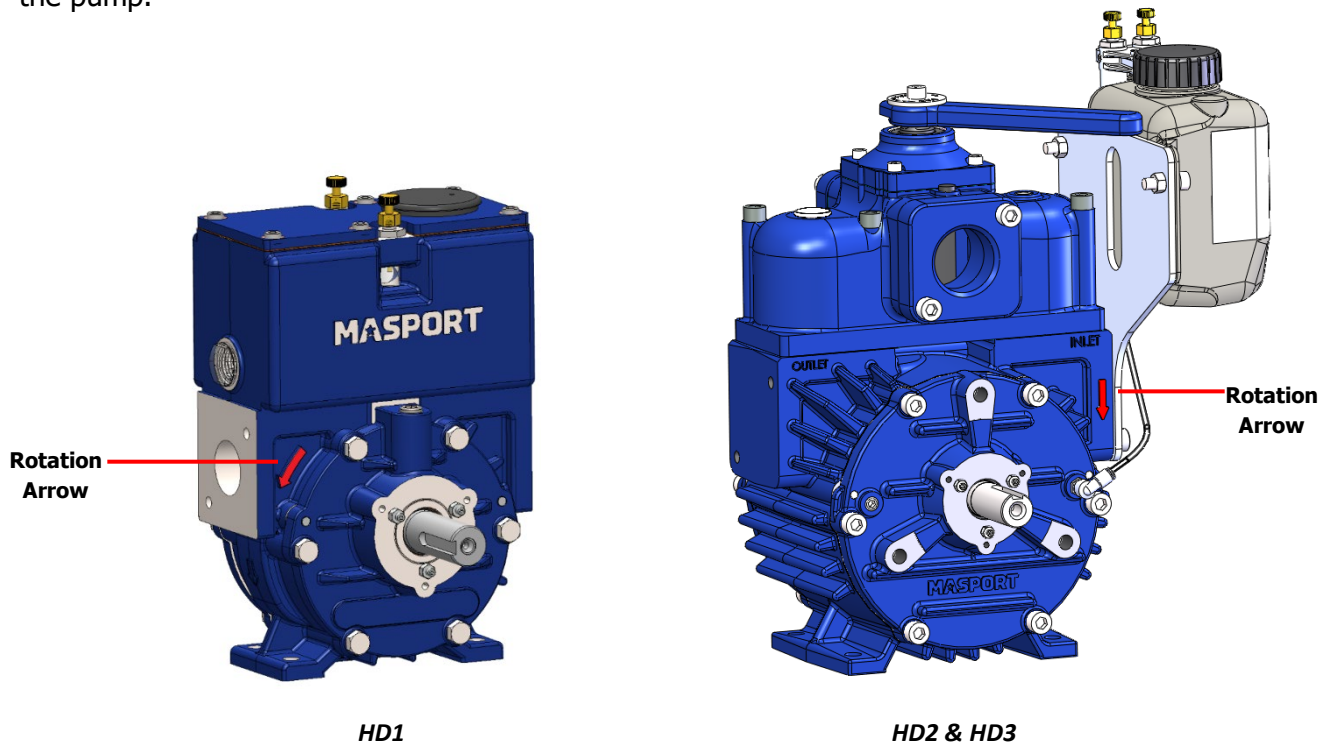

 **WARNING!** Always run the pump in the direction as indicated.

Pump Speeds and Power Requirements

The table below provides the recommended speed and power requirements (hp) for each pump model for optimal pump life and performance.

Pump	Input RPM	Vacuum ("Hg)					Pressure (PSIG)		
		5	10	15	20	27	5	10	15
HD1 & H1	1,250	0.8	0.8	0.9	1.0	1.2	0.9	1.3	1.6
	1,425	0.9	1.0	1.0	1.2	1.4	1.0	1.5	1.8
	1,750	1.1	1.2	1.3	1.5	1.8	1.2	1.9	2.2
HD2 & HXL2	1,250	1.8	2.1	2.2	2.4	2.7	2.9	3.1	3.9
	1,425	2.1	2.4	2.5	2.8	3.1	3.2	3.4	4.3
	1,750	2.6	3.0	3.2	3.5	3.6	4.0	4.3	5.4
HD3 & HXL3	1,250	2.4	2.8	3.0	3.4	3.9	3.5	5.0	6.3
	1,425	2.8	3.3	3.5	3.9	4.5	4.0	5.8	7.3
	1,750	4.0	4.7	5.0	5.7	6.5	5.0	7.1	9.0

» **Note:** Heat build-up is the limiting factor in the pump's performance. Operating above or below the recommended speed range will increase the heat produced and negatively impact the life of the pump.

Vacuum Relief Valve

The vacuum relief valve should be set at a maximum continuous working vacuum level of 25" Hg at sea level for Liquid Cooled Pumps and 20" Hg at sea level for Air Cooled Pumps for optimum pump life and performance.

The working vacuum level should be decreased by 1" Hg for every 1,000ft of elevation.

To set the vacuum relief valve:

- ▶ Unscrew and remove the Dust Cap.
- ▶ Loosen the Lock Nut and adjust the vacuum level by increasing or decreasing spring tension with the Adjusting Nut.
- ▶ When the vacuum level is set retighten the Lock Nut and screw the Dust Cap back on.

The vacuum relief valve setting should be verified by using a quality liquid filled vacuum gauge.

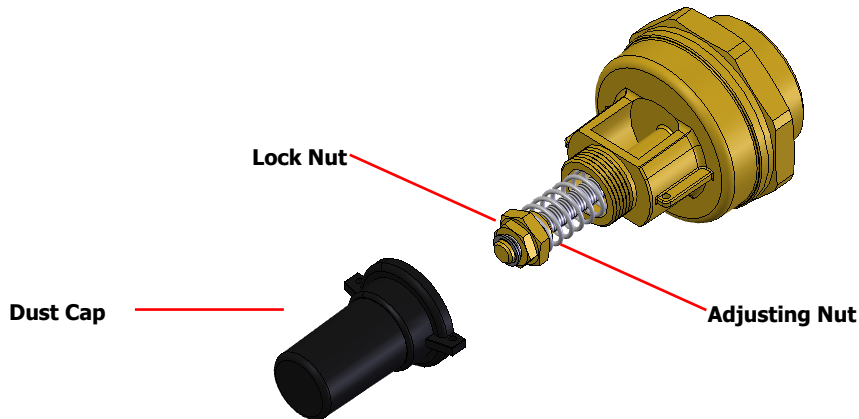

Warning! The vacuum relief valve is not pre-set.



Scan or Click the QR Code to Watch
How To Set A Vacuum Relief Valve



Pressure Relief Valve

It is recommended to set the pressure relief valves below 10 PSI. This level is adequate in majority of applications.



WARNING! For pressure settings above 15 PSI the tank manufacturer should be consulted for recommended operating pressures.

To set the pressure relief valve:

- ▶ Unscrew the Lock Nut.
- ▶ Using a 15mm wrench turn the Spring Tensioner clockwise to increase the pressure and counterclockwise to reduce pressure.
- ▶ When the pressure level is set retighten the Lock Nut.

The pressure relief valve setting should be verified by using a quality liquid filled pressure gauge.

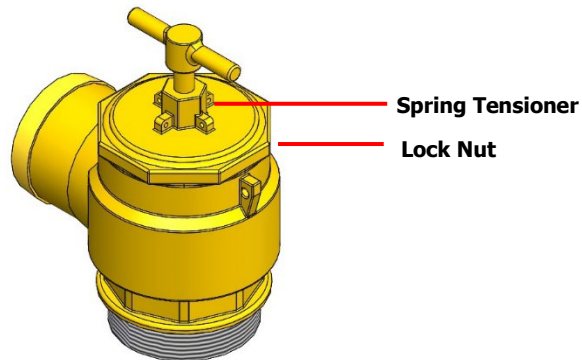



Scan or Click the QR Code to Watch

How To Set A Pressure Relief Valve



Pump Lubrication

Rotary Vane Vacuum Pumps require a high quality non-detergent Rotary Compressor Oil or Rotary Turbine Oil. Oil specifically formulated for Masport pumps is available from your local Masport representative or by contacting Masport directly.

Part Number	Volume	Type
13980	1 Gallon	All Seasons Oil
13983	4 Gallons	All Seasons Oil
13984	12 Gallons	All Seasons Oil

 **WARNING!** Do not use transmission fluid, automotive motor oil, power steering fluid, used oil, vegetable oil, brake fluid, hydraulic fluid, gear oil or scented oil in a Masport pump.

Substitute oils approved for use in Masport pumps:

- ▶ Shell Turbo T Oil 32, 68, 100
- ▶ Monolec Compressor Oil
- ▶ Mobil SHC 525 (Synthesized Hydrocarbon)
- ▶ Anderol 497
- ▶ Chevron GST 32, 68
- ▶ Regal Oil R & O 32, 68

» **Note:** Oils numbered 32 & 46 are for winter use. Check pour point to determine minimum temperature. Oils numbered 68 & 100 are for summer use.



Scan or Click the QR Code to Purchase
Oil & Oil Reservoir Kits



The Masport HD1, HD2 and HD3 pump utilize two adjustable oil sight feed valves, commonly referred to as Drippers, to lubricate the pump.

For the HD1 Pump the Drippers and oil reservoir are integrated into the pump, where for the HD2 and HD3 Pumps the drippers and oil reservoir are remote mounted to the pump.

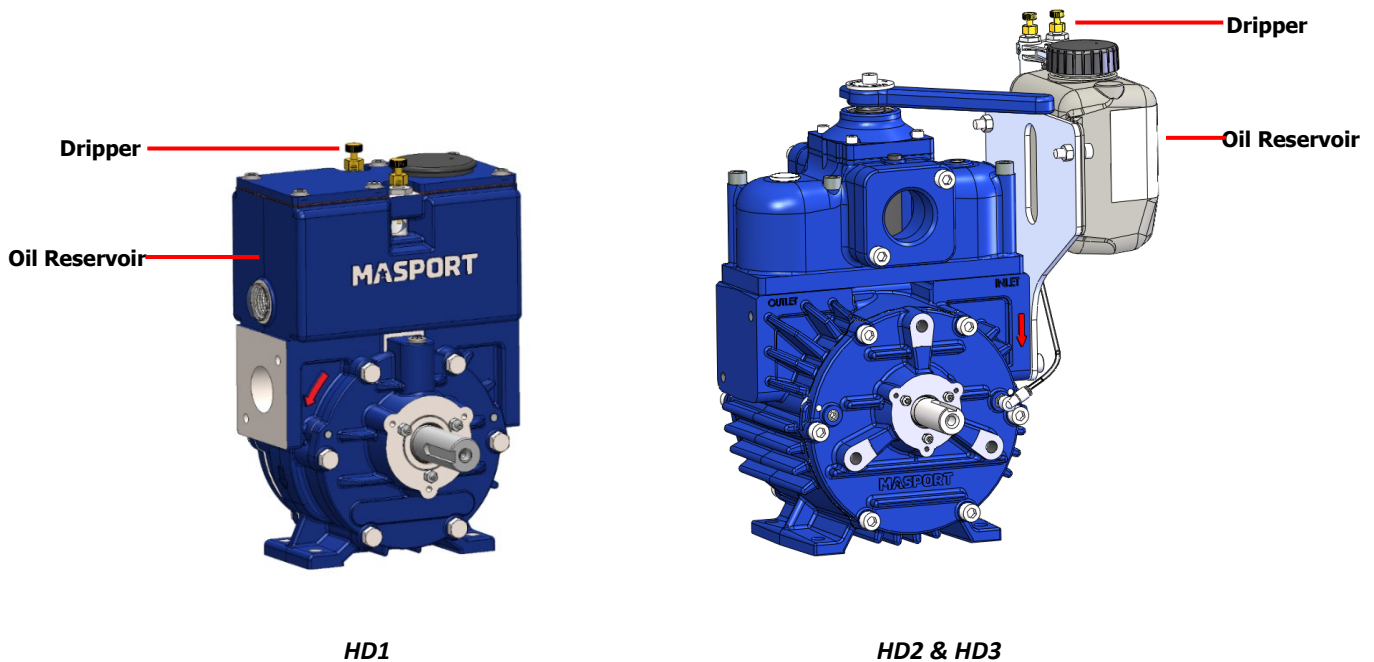

The rate of oil supply to the pump can be checked by observing the drops falling inside each Dripper through the sight glass. This should only be finalized when the vacuum pump has fully warmed up (i.e. after approximately 30 minutes of running.) The flow rate should be adjusted to no less than the recommended drop rate shown below:

For operating at a vacuum level of 15" or above:

Pump	Drips Per Minute
HD1 & H1	6
HD2	7
HD3	8

For extended operation at lower vacuum levels it is recommended to increase the drip rate to ensure the required minimum drip rates above are achieved at your operating vacuum level.

The oil flow rate can be adjusted by turning the Adjusting Screw clockwise to reduce, counter-clockwise to increase. Ensure the Locking Gland Nut is tight to avoid Dripper adjustment while the pump is operational.

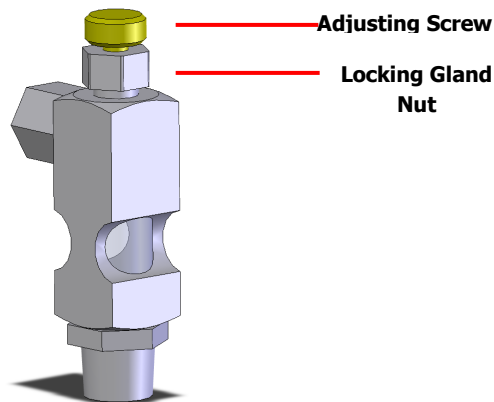

To enhance protection against contamination damage it is recommended to have the oil flows exceed the minimum rate.

Prior to Start-Up:

Before running the pump for the first time (and any time after pump teardown or if it has been out of service for some time) follow the below procedure:

- ▶ Ensure there is adequate pump oil in the oil reservoir.
- ▶ Pour 1 - 2 oz. of pump oil into the vacuum pump inlet and rotate the pump by hand several times to coat the cylinder with a fresh film of oil.
- ▶ After start-up, observe the transparent oil lines coming from the Drippers to confirm that oil is flowing from the Drippers to the Pump.

Flushing Information

Masport vacuum pumps require little regular maintenance except for flushing the pump weekly or anytime liquid or solids have been allowed to enter the pump. A flushing kit is used to introduce small amounts of flushing fluid into the pump to cleanout debris and inhibit rust.

Masport pumps are best flushed by using the Masport specially formulated Flushing Fluid. This is available from your local Masport representative or by contacting Masport directly.

Part Number	Volume	Type
13989	1 Gallon	Flushing Fluid
13991	4 Gallons	Flushing Fluid
13992	12 Gallons	Flushing Fluid



Scan or Click the QR Code to Purchase

Flushing Fluid & Flushing Kits



Flushing Procedure:

Flushing frequency: weekly, preferably at the end of a workday, more often if carry-over from traps contaminate the pump.

- ▶ Connect the Flushing Kit to the flushing port on valve of the pump.

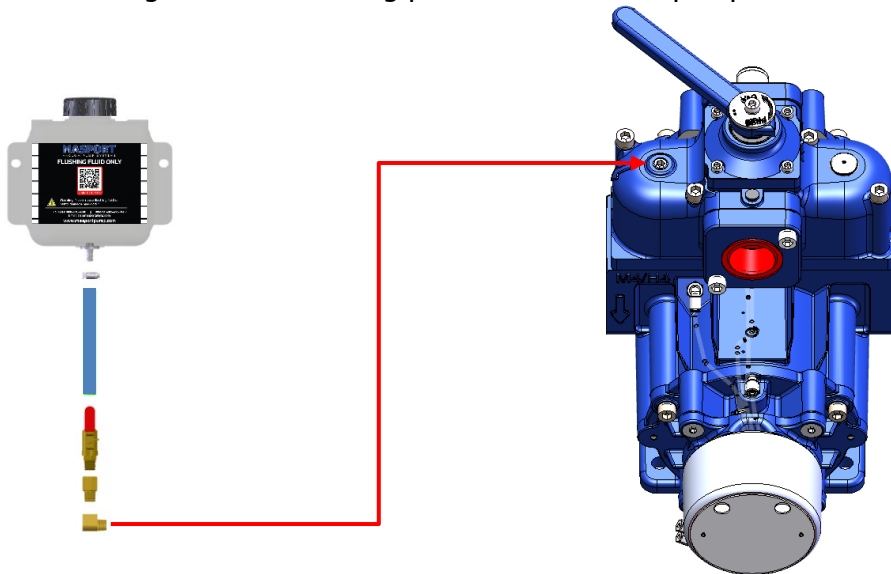

- ▶ Start the vacuum pump and bring vacuum to 15"Hg.
- ▶ Open the ball valve to begin flushing fluid flow.

- ▶ Continue to run the pump until the fluid level drops 1 graduation (approximately 7 fluid ounces).
- ▶ Close the ball valve.
- ▶ Continue to operate the pump for 3 additional minutes to ensure all fluid is purged from the pump.
- ▶ Stop the pump and move the handle to the neutral position.
- ▶ Drain the oil separator and dispose of used fluid at an approved recycling site.

Maintenance and Important Operating Tips

To keep the pump in a workable condition, operators should undertake regular maintenance and keep a written log of those checks.

Before Starting:

- ▶ Ensure a vacuum relief valve and pressure relief valves are installed in the system and adjusted to recommended settings, taking into account the altitude of the job location.
- ▶ Always bleed the tank to atmospheric pressure before switching the valve from vacuum to pressure or from pressure to vacuum.

Every Load:

- ▶ Drain the scrubber after each tank load. If nothing drains when the ball valve is opened never assume it is empty, check for a blockage in the valve.
- ▶ Check the oil level in the oil reservoir and fill as required.
- ▶ Monitor vacuum/pressure and temperature gauges to detect any irregularities or problems.

Daily:

- ▶ Add oil approximately every 10 hours of operation or when the oil reservoir shows the level is low. Only use approved lubricants.
- ▶ Drain the oil separator daily or every time switching the pump from vacuum to pressure mode.

Weekly:

- ▶ Check to ensure the vacuum pump RPM is within the recommended range. Running the pump too fast or too slow may cause damage.
- ▶ Flush the pump weekly with Masport Flushing Fluid, or anytime liquids or solids have been allowed to enter the pump.
- ▶ Check and clean the Inlet Filter. Ensure the filter is completely dry before refitting. This checking process must be done anytime contamination may have entered the system.
- ▶ Check to ensure the pump RPM is within the recommended range. Running the pump too fast or too slow may cause damage.
- ▶ Wash any dirt off the pump as it needs to be clean to allow heat to radiate and prevent it from overheating.

Annually:

- ▶ Check bolt mountings, drive coupling alignment and condition and vane wear.

Storage:

- ▶ If the pump is to be sitting for an extended period of time it needs to be flushed prior to storage. After flushing, pour oil into all bearing lubrication ports to protect the bearing

surfaces and oil injection points on the pump to eliminate rust formation on the rotor and cylinder.

- ▶ Rotate by hand monthly to distribute oil.

For Safe Operation:

- ▶ Wear the correct Personal Protective Equipment.
- ▶ Never use the pump to move flammable or highly caustic material.
- ▶ Do not open any ball valve on any components when the tank is under vacuum, as this will cause foreign material to enter the pump.
- ▶ Do not over speed or under speed the pump as either will cause overheating.
- ▶ Do not engage power take off at high RPM. Only engage at idle.
- ▶ Always disengage the pump when driving to or between job sites.
- ▶ Never run the pump without oil
- ▶ Never spin the pump backwards.
- ▶ Never remove the stub shafts from the rotor. The rotor has been machined as a complete unit for exact balance. Removing the stub shafts will destroy the factory-set clearances and balance.
- ▶ No maintenance should be undertaken, or parts be removed if there is either pressure or vacuum in the tank.

Troubleshooting

The Pump Overheats

Potential causes to check and resolve:

- ▶ Incorrect oil, or no oil in the pump.
- ▶ RPM in excess of recommended levels.
- ▶ Continued operation above recommended maximum vacuum and pressure levels.
- ▶ Blocked Inlet Filter.
- ▶ Pump is covered in mud and/or dirt.
- ▶ Plumbing diameter is of an insufficient size.
- ▶ Blockage in exhaust.

The Rotor does not Rotate

Potential causes to check and resolve:

- ▶ Damaged vane(s).
- ▶ Damaged bearing(s).
- ▶ Issue with the drive system.
- ▶ Ice frozen inside the pump.

The Pumps Performance is Impaired

Potential causes to check and resolve:

- ▶ Four-way valve is in the neutral position or not fully open to vacuum or pressure.
- ▶ Worn vanes.
- ▶ Worn shaft seals.
- ▶ Leaks in the tank or pipework.
- ▶ Plumbing diameter is of an insufficient size.
- ▶ Non-return valve is blocked and does not open fully.
- ▶ Blocked Inlet Filter.
- ▶ RPM rate below recommended level.
- ▶ Collapsed hose in the system setup.
- ▶ Blockage in exhaust.
- ▶ Fluid has entered the pump.

For further issues or additional information contact an authorized Masport distributor or Masport directly.

Pump Service

The following repair techniques are given for use on pumps that do not have damage to the cylinder or end covers to the extent that they need to be re-machined. These procedures are intended for use when the vanes and bearings of the pump require replacement. They should not be considered as total rebuild instructions.

» **Note:** Any service or repair work on your pump should be performed by a qualified mechanic with the proper tools and experience working with vacuum pumps.

Installations requiring re-machining of the pump components should be done by an authorized Masport repair facility. For the nearest authorized rebuild center, contact Masport directly.

Replacement Parts Kit:

The Replacement Parts Kits contains all the necessary components to rebuild or service your pump. All Rebuild Kits contain the following items:

- ▶ Vane Pack.
- ▶ Bearings.
- ▶ Bearing Spacers (where fitted).
- ▶ Oil Seals.
- ▶ End Cover Shims.
- ▶ Valve and Flange Gaskets.

Pump	Replacement Parts Kit Code
HD1 & H1	14613
HD2	14652
HXL2	14637
HD3	14653
HXL3	14638



Scan or Click the QR Code to Purchase
Pump Replacement Parts Kit



Disassembly:

The following instructions are written, assuming that the pump being serviced has been removed from the base it was mounted on. It is possible to carry out installation of the parts kit with the pump mounted, but for best results it is recommended that it is removed from the stand.



WARNING! Disconnect the pump drive to ensure the pump cannot be accidentally started during service and to allow the shaft to be rotated by hand.

Before removing the cylinder end cover, clean the outside of the pump to prevent dirt and debris from getting into the cylinder.

Mark the drive side end cover and the corresponding end of the cylinder and rotor shaft, using a centre punch. Marking these will avoid the possibility of assembling the pump with the end covers on the wrong ends, or the rotor refitted in the incorrect orientation.

HD Series:

For the HD2 and HD3 Pumps disconnect the oil lines from the fittings on each end cover of the pump. From the non-drive end of the pump remove the shaft guard.

HXL Series:

If working from the oil pump end of the cylinder, start by removing the shaft guard and oil pump guard. The oil pump guard bolts are longer than the other end cover bolts so their location should be noted. Disconnect the oil line to the fitting in the end cover and remove the oil pump. The oil pump mounting screws are different lengths, so note their locations as they are being removed. Remove the oil pump drive assembly.

End Cover Removal:

Remove the bolts around the perimeter of the end cover.

In order to maintain factory set clearances avoid damaging the dowel pins during end cover removal. To properly remove the end cover, work evenly from each side of the cover, which will help to avoid misalignment of the end cover and bending of the dowel pins. Ensure that the rotor does not slide out with the end cover. As necessary use a rubber mallet to drive the rotor shaft back towards the end cover that is still bolted on to free the end cover from the bearing.



WARNING! Under no circumstances should the end cover be pried or hammered off the cylinder as this will potentially result in damage to the sealing surfaces.

The end clearance is adjusted by means of Shim Gaskets between the end cover and the cylinder. Make note of the type and quantity of any Shim Gaskets when removing the end cover. The matching type will need to be used on reassembly.

To identify the type of Shim Gasket, look for the marker holes on the which identify the thickness – i.e. two holes indicates a thickness of 0.002” and three holes indicates a thickness of 0.003”

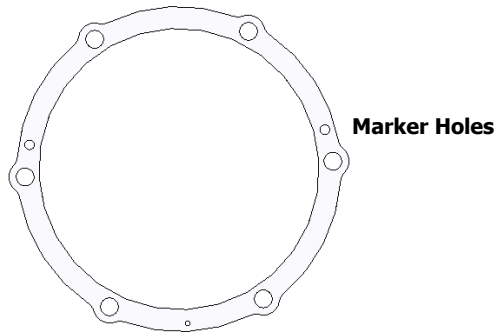

» **Note:** If simply replacing the vanes only please skip to the Vane Wear Check section in Parts Inspection, Cleaning and Replacement.

Rotor Removal:

With the one end cover removed, the rotor can be pulled out of the cylinder. The bearings are a slip fit in the end covers, but due to the tight clearance, the bearing may bind in the end cover if it is not pulled out straight. If it does not pull free on the first try, put it all the way back in, using a rubber mallet, and start over again. Putting it all the way back in will realign the bearing with the housing and allow it to pull free from the cover.

Once the rotor has been removed, the remaining end cover can be removed, as required, by following the same procedure detailed above in the End Cover Removal section.

Parts Inspection, Cleaning and Replacement:

Vane Wear Check:

The pump should be inspected for vane wear at least once a year. If vane wear is not monitored, the vanes can become too short causing excessive rotor and cylinder wear and eventually result in vane breakage.

Measure the vanes to see if they are within the usable limit. If they are not, they should be discarded and replaced. The vanes should be replaced when their height is below the usable limit detailed in the table below:

Pump	Vane Usable Height (")
HD1 & H1	> 1 7/16"
HD2 & HXL2	> 1 11/16"
HD3 & HXL3	> 1 11/16"

Inspect the sides of the vanes to see if they are bent, out of parallel, worn to a concave shape on one side or have frayed edges. Any of these conditions require part replacement. These characteristics could indicate foreign material caught alongside the vane, a burr in the edge of the rotor slot or improper lubrication. Each of these possible causes should be investigated and corrected before the pump is reassembled.

Inspect the edge of the vane that contacts the cylinder for frayed edges. If detected this requires part replacement. Frayed edges can indicate improper lubrication or that the pump has been operated for extended periods of time beyond its rated limits. Each of these possible causes should be investigated and corrected before the pump is reassembled.

» **Note:** If simply replacing the vanes only please skip to the Installing the Vanes section in Reassembly.

Cylinder Inspection:

With the end cover removed inspect the cylinder for damage or corrugation. Prior to inspection, the cylinder should be cleaned inside and out to allow a more thorough inspection.

Inspect the interior of the cylinder for cracks and deep gouges around the circumference and corrugation across the length of the bore. Cracks in the housing will require part replacement.

The detection of corrugation or gouges across the length of the cylinder can indicate inadequate horsepower transfer, operation below minimum recommended speeds, foreign material sticking the vanes in their slots, or operation beyond recommended vacuum limits. Each of these possible causes should be investigated and corrected before the pump is reassembled.

» **Note:** If cylinder scoring is deeper than .005" or if corrugation can be felt the cylinder should be bored, honed and the seal gap reset.

Bearing and Spacer Inspection:

It is difficult to visually determine the condition of a bearing. If there is obvious damage such as discoloration (bluing) of the bearing or the race, there is definite damage and the bearing and spacer should be replaced.

» **Note:** There is no guarantee that the bearings are not damaged and with the pump disassembled to this point, it is advisable to replace them.

The outer circumference of the spacer should be inspected for signs of contact with the bore of the end cover bearing housing. If there has been contact, it could be a sign that the bearing is worn and needs to be replaced.

Bearing and Spacer/Shim Removal:

Before removing the bearing and spacer/shim any burrs on the shaft should be removed with a flat file.

Once the shaft is free of burrs, the bearing and spacer can be pulled by means of a bearing puller. Bearings should be removed only using the proper tools. A bearing puller is the only tool that will give satisfactory results. Prying or hammering will only risk damage to the components.

» **Note:** The spacers/shims are not reusable and must be replaced when removed.

Do not install new bearings and spacers/shims at this time. Follow the Rotor Inspection and Cleaning instructions first.

Rotor Inspection and Cleaning:

Inspect the rotor carefully for any cracks - especially if disassembly was due to pump seizure. Any cracks in the rotor will require replacement of the part.

With the bearings and spacers removed, lightly file with a flat file along all edges of the vane slots to remove any burrs or nicks that may have occurred from either contact or from foreign material.

Once all the burrs are removed, the ends and diameter of the rotor should be gone over lightly with 400 grit wet/dry sandpaper to remove any carbon or varnish deposits left by the oil.

Bearing and Spacer Replacement:

For the HD1 and H1F Pumps fit a new spacer on each shaft and slide the spacer down to contact the rotor face. Ensure that the spacer is installed on the rotor shaft with the large chamfer facing towards the rotor.

For the HD2, HXL2, HD3 and HXL3 Pumps fit a new shim on each shaft and slide the shim down to contact the rotor face. The shim is symmetrical so can be placed on in either orientation.

» **Note:** Incorrect installation of the spacer will cause bearing failure and damage to the pump.

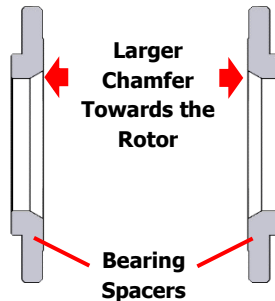

The new bearings and spacers can be pressed onto the shaft using a bearing press. When pressing them on ensure the pressure is only applied to the bearing inner race. If a bearing press is unavailable a length of pipe can be used to drive the bearing onto the shaft. If this method is used ensure that the pipe diameter is equal to the bearing inner race, and any dirt or pipe scale is removed before use to prevent contamination.

End Cover Inspection and Cleaning:

Each of the end covers should be inspected for surface damage from rotor-to-end cover contact and the bearing housing inspected for signs of spacer-to-bore contact.

If the end covers have been damaged by rotor-to-end cover contact and there are grooves worn in more than .005" deep, the face should be resurfaced. If there is no damage, or the damage is minor, the face of the end cover should be wiped clean with solvent and then lapped with the lapping compound against the other end cover. Once complete the covers should be wiped, cleaned, and dried off with an air hose to remove any traces of lapping compound that could cause damage during assembly or start-up.

If the bearing housing bore is damaged, it can be cleaned up with a small file or 400 grit wet/dry sandpaper to remove any burrs. If either of the bearings had seized and spun in the housing, the fit should be checked with a new bearing, to ensure that there is not excessive clearance.

Oil Seal Replacement:

The oil seals can be removed by inserting a screwdriver or punch through the shaft bore of the end cover on the oil seal to drive the seal out.

Place the new oil seal in the seal housing. Ensure that the oil seal is installed with the spring side of the seal facing into the bearing bore of the end cover.

» **Note:** Incorrect installation of the oil seal will potentially result in oil leaks around the shaft and bearing failure.



The oil seal should be pressed into the seal bore on the end cover using a seal press or a flat round disc approximately the same outside diameter as the oil seal. Care must be taken to press the oil seal into the bore evenly to prevent damage.

Reassembly:

The area to be used for reassembly should be thoroughly cleaned to prevent contamination during the reassembly process.

Installing the First End Cover

If both end covers have been removed from the cylinder the below procedure needs to be followed.

Spread a small amount of oil around the cylinder face to hold the end cover Shim Gaskets in place.

Place the new end cover Shim Gaskets (the correct quantity and type that were removed during the disassembly process) over the dowel pins and onto the oiled face of the cylinder.

Align the end cover dowel pin holes with the dowel pins in the cylinder face. Drive the cover on evenly with a rubber mallet working from side-to-side to prevent bending the dowel pins or distorting the holes in the end cover.

Install the end cover retaining bolts and torque them to 29-30 ft/lbs. When tightening work across the cover, alternating from one side to the other to ensure even pressure.

Apply a small amount of grease to the lip of the oil seal.

Installing the Rotor Assembly:

HXL Series:

Reinstall the worm gear for the oil pump drive and tighten the set screw.

All Models:

Spread vacuum pump oil around the cylinder bore to avoid damage to the rotor and cylinder bore when refitting the rotor.

Inspect the ends of the rotor shaft to find the reference mark made during disassembly to ensure correct rotor-end cover-cylinder relationships. Once determined slip the rotor assembly into the cylinder and the bearing into the end cover bore taking care to avoid damage to the seal on the shaft keyway. The bearing should slip in the cover house easily with only a slight tap with a rubber mallet. If the fit is extremely tight, the end cover bore should be examined for burrs and cleaned up. The bearing must be free to move slightly in and out of the cover bore without extreme force or damage to the pump will potentially occur.

Installing the Vanes:

To install the vanes rotate the rotor so the free vane slot faces the bottom of the cylinder. Insert the new vane by sliding it along the cylinder wall. Be sure the vanes slide freely in the rotor.

Vanes for the HD2, HXL2, HD3 and HXL3 model pumps have a radiused edge. Install them with the radius in contact with the cylinder wall.

Vanes for the HD1 and H1 pumps have an offset bevel. Install these vanes with the bevelled edge in contact with the cylinder wall and the leading edge facing in the direction of rotation.

» **Note:** Make sure the vane is oriented correctly. The chamfered edges of the vane must be inserted into the rotor.

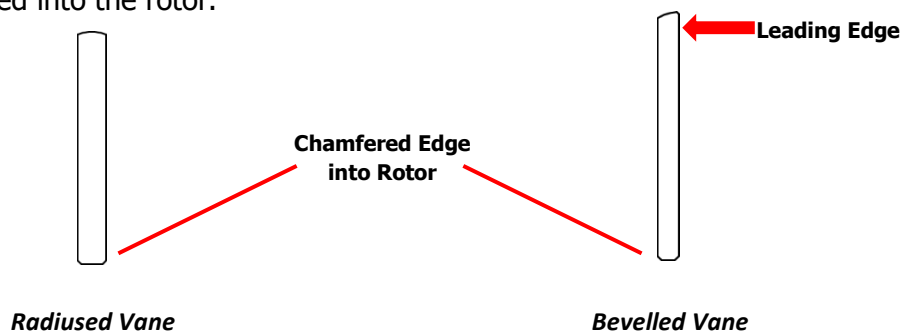

Installing the Second End Cover:

Repeat the procedure of installing the first end cover.

Apply a small amount of grease to the lip of the oil seal, remove the shaft support and fit the end cover over the end of the shaft taking care to avoid damage to the seal on the shaft keyway. Lift the end cover and rotor assembly to align the dowel pins in the cylinder face and the end cover dowel pin holes. This procedure sets the seal gap between the rotor and the cylinder bore.

Once the pins are aligned, the cover can be driven against the cylinder face with a rubber mallet.

Install the end cover retaining bolts and torque them to 29-30 ft/lbs. When tightening work across the cover, alternating from one side to the other to ensure even pressure.

Installing the Oil System

HD Series:

For the HD2 and HD3 Pumps reconnect the oil lines from the outlet of the dripper to the fitting on each end cover of the pump. Refit the shaft cover guard on the non-drive end of the pump.

HXL Series:

If the oil pump was removed, reinstall the drive assembly. Align the hole in the drive assembly with the oil inlet elbow and push the assembly in until it bottoms out. Engage the drive of the oil pump with the slot in the drive assembly and reinstall the oil pump. Prime the oil lines and reconnect the lines from the oil pump to the inlet fittings. Refit shaft cover guard.

All Models:

If all is correct the rotor should turn freely at this point and the pump can be reinstalled on the system.

If the rotor does not turn freely, either one of the vanes is installed crooked and caught on a bearing spacer or the rotor is jammed against one of the covers due to a bearing sticking in the housing. Before disassembling, strike the end of the rotor shaft with a rubber mallet and check for free rotation. It is possible for a bearing to become slightly stuck in the bore, or the rotor is tight against an end cover and will not turn due to lack of lubrication. If this does not cure the problem, disassemble the pump following the procedure for End Cover Removal detailed above.

Note: Be sure to lubricate the pump before initial start-up to prevent damage in the first few seconds of operation. Pour oil into the intake of the pump valve or into the cylinder oiling fittings and rotate by hand to distribute, and if fitted bleed the oil pump.

Before refitting the pump, it is recommended that all of the system filters and traps are thoroughly cleaned and dried before the vacuum pump is operated.

Rebuild Specifications:

Cylinder Remachining:

If the cylinder scoring is deeper than .005" or if corrugation can be felt the cylinder should be bored, honed and the seal gap reset. In reboring the cylinder, the aim is to remove the minimum level of material to achieve the original manufactured finish. Therefore, the cylinder should only be machined down to the deepest scoring/corrugation.

» **Note:** If the scoring/corrugation is deeper than the maximum remachining boring depth then the cylinder or pump will need to be replaced.

The cylinder remachining for each of the pumps should meet the specifications detailed in the table below:

Pump	Manufactured Diameter	Max Remachined Diameter	Honed Surface Finish
HD1 & H1	4.72"	4.76"	0.4 µm
HD2 & HXL2	6.77"	6.81"	1.6 µm
HD3 & HXL3	6.77"	6.81"	1.6 µm



WARNING! Do not exceed the maximum remachined diameter. By exceeding the maximum diameter it presents the risk of compromising both structural integrity and durability of the vacuum pump. Increased bore diameter will reduce vane support therefor reducing vane life and increases risk of vane breakage.

Checking and Setting the Seal Gap Clearance:

If the cylinder has been rebored and/or honed the seal gap clearance needs to be checked and set as required.

The seal gap is the distance between the outer diameter of the rotor and the top of the inside of the cylinder bore. The seal gap is set at a certain specification to provide the maximum performance and efficiency.

The seal gap clearance for each of the pumps should meet the specifications detailed in the table below:

Pump	Seal Gap	Tolerance
HD1 & H1	0.0015"	+/-0.0005"
HD2 & HXL2	0.0015"	+/-0.0005"
HD3 & HXL3	0.0015"	+/-0.0005"

This clearance can be checked by inserting the proper sized feeler gauge in the exhaust port of the pump across the top of the rotor to the inlet side of the pump.

» **Note:** When checking the seal gap clearance, the rotor should be turned so that none of the vane slots are at the top of the cylinder.

To accurately check the clearance this should be done at three points: in the center of the pump; and at each end of the rotor near the end cover. This will help ensure that the rotor is parallel with the cylinder bore.

If the clearance is within specification the dowel pins will not have to be refitted.

If the seal gap clearance needs to be reset the following technique can be used.

» **Note:** To reset the seal gap clearance, the dowel pins on the inlet side on both ends of the cylinder need to be removed.

- ▶ Place the correct sized feeler gauges in position in the cylinder.
- ▶ Turn the pump upside down. For this to be possible the valve assembly will need to be removed to allow the cylinder to rest flat.
- ▶ Loosen the end cover bolts on both end covers.
- ▶ Allow the end covers to pivot on the cylinders exhaust side dowel pins bringing the rotor into contact with the feeler gauges.
- ▶ Re-torque the end cover bolts evenly on both end covers.
- ▶ Turn the pump over and re-check the seal gap clearance. Repeat the process if the seal gap clearance is still out of specification.
- ▶ If within specification drill and ream to fit either new oversized dowel pins or to reposition the original dowels pin.
- ▶ Clear swarf from the drilled holes and fit the dowel pins to secure the setting.

Checking and Setting the End Float Clearance:

The end float clearance is the distance of travel between the end faces of the rotor and the end covers. The end clearance is set at a certain specification to provide the maximum performance and efficiency.

The end float clearance for each of the pumps should meet the specifications detailed in the table below:

Pump	End Float Minimum	End Float Maximum
HD1 & H1	0.003"	0.005"
HD2 & HXL2	0.003"	0.005"
HD3 & HXL3	0.004"	0.006"

To set/check the end float clearance the following procedure should be used:

➤ **Note:** The following procedure requires the use of a dial indicator and either a magnetic stand or a stand that can be bolted to one of the end cover tapped or threaded holes.

- ▶ Mount the dial indicator stand on the pump end cover and attach the Dial Indicator so that the end of the indicator is on the end of the pump shaft. The travel axis of the indicator must be on the same line as the axis of the pump shaft.
- ▶ Push the rotor firmly until it becomes tight against the end cover being set.

➤ **Note:** In order to set /check the end float clearance correctly, the three end thrust protection screws will need to be removed from each end cover.

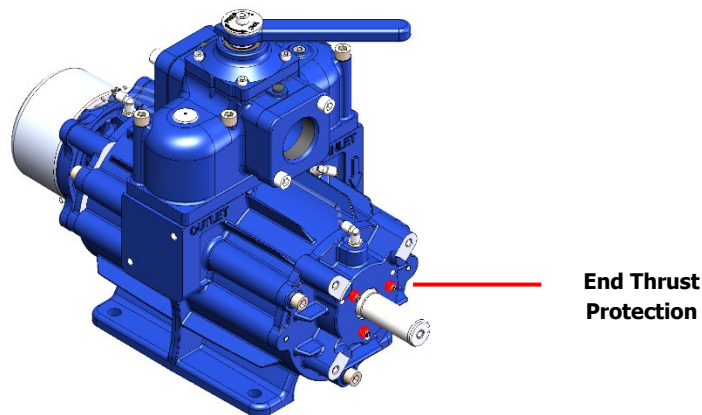

- ▶ Zero the Dial Indicator.
- ▶ Push the rotor back firmly against the other end cover and note the Dial Indicator reading.

- ▶ The difference between the two readings is the total amount of end float. Check that the clearance value is within the range as specified in the table above.
- ▶ If the clearance is below the minimum an end cover will have to be removed and an end cover shim gaskets added to attain the proper clearance.
- ▶ If the clearance is above the maximum an end cover will have to be removed and an end cover shim gaskets removed to attain the proper clearance.
- ▶ If gaskets were added or subtracted, the above process will need to be repeated to changes made were correct and the pump is within specification.

Setting the End Thrust Protection:

Thrust screws are fitted into the end cover of the pumps. These thrust screws limit the travel of the rotor between the end covers, reducing the risk of rotor to end cover contact. This allows the pump to be direct driven without damage to the rotors or covers from lateral thrust loads produced by the drive system.

The end thrust protection for each of the pumps should meet the specifications detailed in the table below:

Pump	End Thrust	Tolerance
HD1 & H1	0.001"	+/-0.0005"
HD2 & HXL2	0.001"	+/-0.0005"
HD3 & HXL3	0.001"	+/-0.0005"

To set the end thrust protection the following procedure should be used:

» **Note:** The following procedure will require the use of a dial indicator and either a magnetic stand or a stand that can be bolted to one of the end cover bolts.

- ▶ Position the pump horizontally.
- ▶ Fit three thrust screws with lock nuts to one of the end covers. Apply Loctite 567 thread sealant to thrust screws prior to screwing in.



WARNING! Do not place any sealant directly into the tapped holes in the end cover. This could result in bearing contamination.

- ▶ Mount the dial indicator stand on the pump end cover and attach the Dial Indicator so that the end of the indicator is on the end of the pump shaft. The travel axis of the indicator must be on the same line as the axis of the pump shaft.

-
- ▶ Push the rotor firmly until it becomes tight against the end cover being set.
 - ▶ Zero the Dial Indicator
 - ▶ Tighten the three thrust screws until they just touch the bearing race. This will be indicated by the Dial Indicator needle starting to move off zero.
 - ▶ Once the thrust screw are in contact with the bearing, tighten them progressively to move the rotor off the cover by the value as specified in the table above.



Note: Make the first adjustments of 0.0005" Dial indicator movement for each screw. Then make small fractional adjustments of the balance until the total adjustment setting is reached. The last 0.0005" of adjustment should be broken into several small adjustments shared progressively across all three thrust screws.

- ▶ Tighten the lock nuts ensuring the thrust screw does not move and that there is no movement on the dial of the Dial Indicator.
- ▶ Repeat the process on the thrust screws on the other end of the pump.
- ▶ If the vanes had been left out for setting remove an end cover and refit the vanes and end cover.

Exploded Views

HD1:

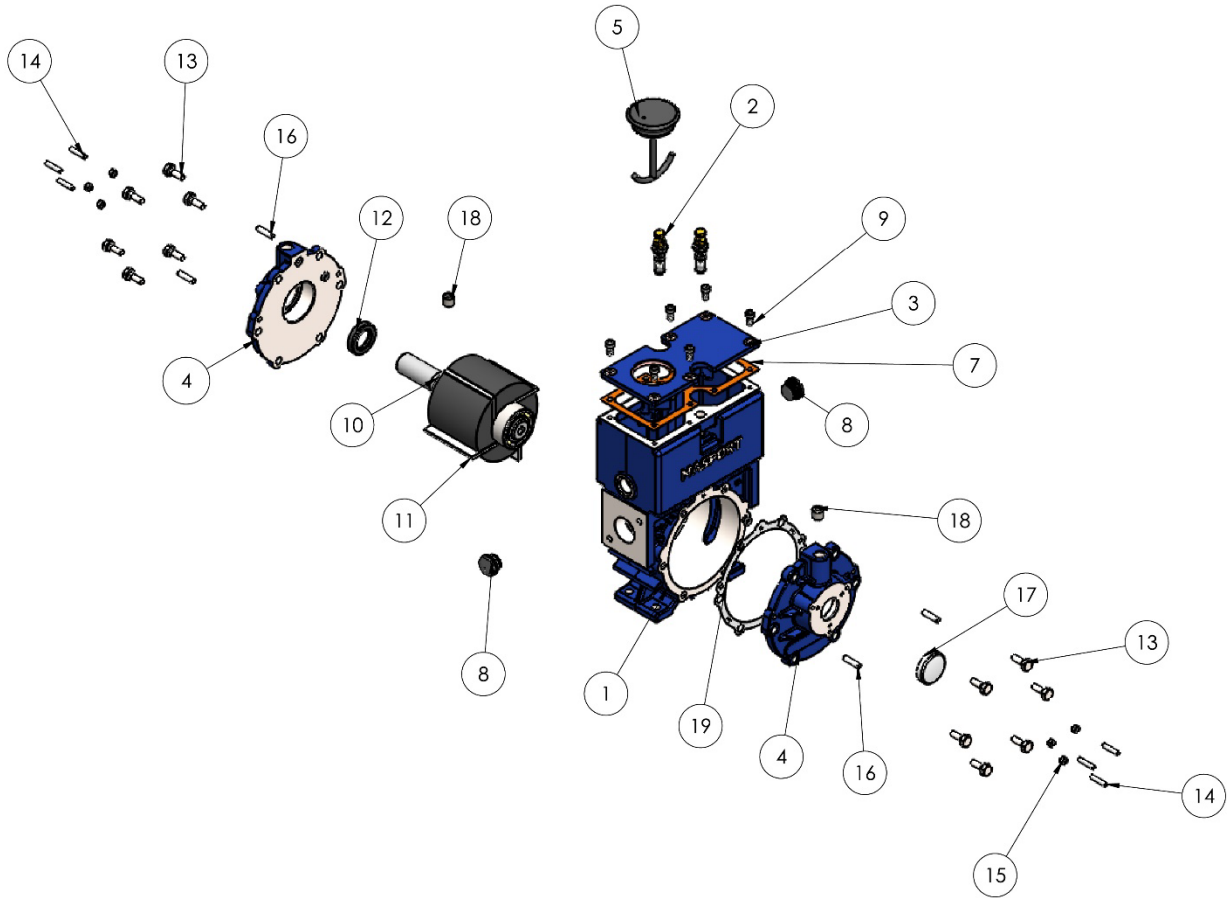

Item	Code	Description	Qty
1	969131	Cylinder	1
2	569146	Dripper	2
3	569137	Oil Reservoir Lid	1
4	968109	End Cover	2
5	969142	Oil Reservoir Cap	1
6	569141	O-Ring	2
7	569138	Oil Reservoir Lid Gasket	1
8	569139	Sight Glass - ½"	2
9	569136	Bolt - M6 x 12	6
10	968154	Rotor Assembly	1

Item	Code	Description	Qty
11	968217	Vane Pack	1
12	501578	Seal - 25 x 40 x 8	1
13	501848	Bolt - M8 x 20	12
14	503225	Grub Screw - M5 x 20	6
15	220221	Nut - M5	6
16	575111	Dowel Pin - 6 x 24	4
17	975132	Frost Plug	1
18	503416	Plug - ¼"	2
19	575026	Shim End Cover - .002"	*

Notes: * Quantities Vary

HD2V:

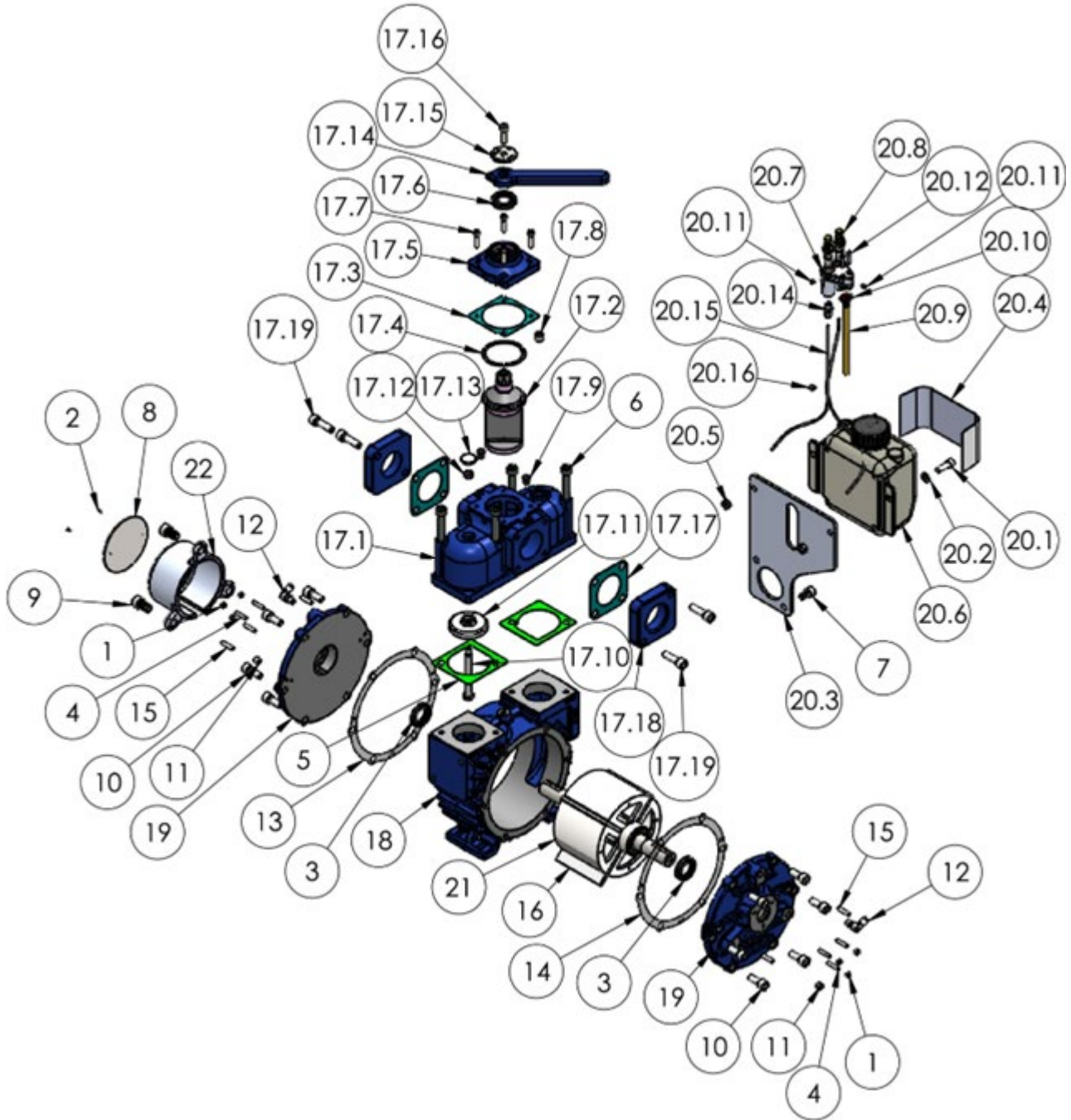

Item	Code	Description	Qty
1	220221	Nut - M5	6
2	500806	Rivet - 2.5 X 6	2
3	501578	Seal - 25 x 40 x 8	2
4	503225	Grub Screw - M5 x 20	6
5	568066	Gasket - Valve	2
6	568249	Bolt - M10 x 100	4
7	569218	Bolt - M10 x 16	2
8	569224	Pump Model Tag	1
9	569236	Bolt - 1/2" x 1/2"	3
10	569538	Bolt - M10 x 25	12
11	569726	Plug - 1/8"	2
12	569948	Oil Line Fitting	2
13	575005	Shim End Cover - .001"	*
14	575006	Shim End Cover - .002"	*
15	575111	Dowel Pin - 6 X 24	4
16	975536	Vane Pack	1
17.1	968359	Valve Body	1
17.2	968362	Spool	1
17.3	568063	Gasket - Valve Cap	1
17.4	568363	Wave Washer	1
17.5	968364	Valve Cap	1
17.6	501578	Seal - 25 x 40 x 8	1
17.7	11049	Bolt - M6 x 25	4
17.8	503416	Plug - 1/4"	1
17.9	568892	Rubber Plug	2
17.10	568343	Shoulder Bolt	1
17.11	968353	Non-Return Valve	1
17.12	504278	Nut - M8	1

Item	Code	Description	Qty
17.13	504288	Plug	1
17.14	668055	Valve Handle	1
17.15	569724	Indicator Washer	1
17.16	11063	Bolt - M8 x 25	1
17.17	36202	Gasket - Flange"	2
17.18	968159	Flange - 1 1/2"	2
17.19	501966	Bolt - M10 x 55	4
18	969202	Cylinder	1
19	969207	End Cover	2
20.1	11063	Bolt - M8 x 25	2
20.2	25059	Washer - M8	2
20.3	33502	Oil Tank Bracket	1
20.4	39111	Oil Tank Sticker	1
20.5	504278	Nut - M8	2
20.6	569209	Oil Tank - 1.5 Quart	1
20.7	969217	Dripper Housing	1
20.8	569146	Dripper	2
20.9	569212	Dip Tube	1
20.10	569213	Dripper Clamp Ring	1
20.11	504264	Grub Screw - M5 x 6	2
20.12	569216	Bolt - M4 x 20	2
20.13	569214	Dripper Clamp Gasket	1
20.14	569947	Oil Line Fitting	2
20.15	600293	Oil Line	*
20.16	503054	Cable Tie	1
21	969223	Rotor Assembly	1
22	969237	Shaft Cover	1

Notes: * Quantities Vary

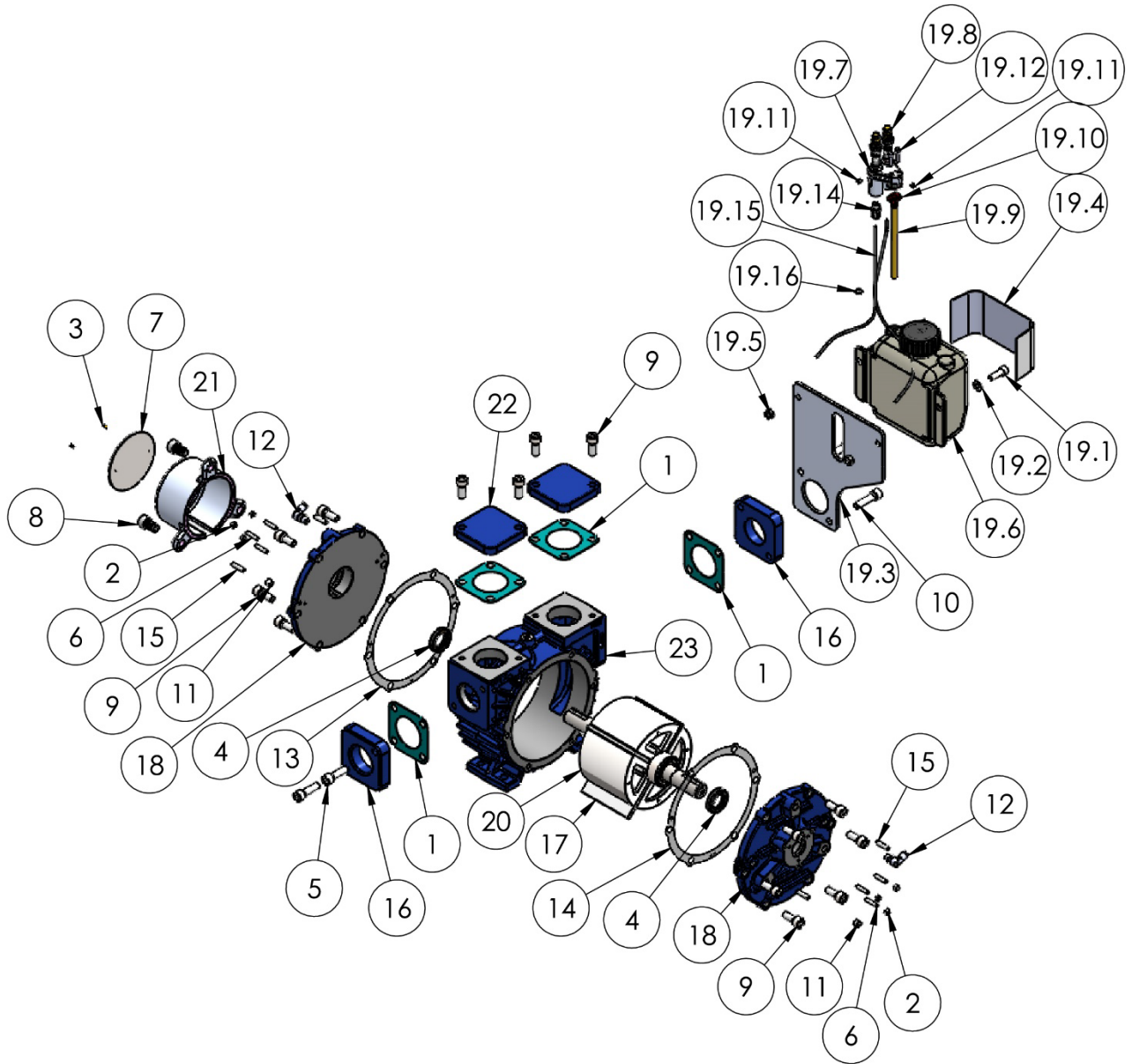
HD2F:

Item	Code	Description	Qty
1	36202	Gasket – Flange	4
2	220221	Nut – M5	6
3	500806	Rivet - 2.5 X 6	2
4	501578	Seal - 25 x 40 x 8	2
5	501966	Bolt – M10 x 35	2
6	503225	Grub Screw - M5 x 20	6
7	569224	Pump Model Tag	1
8	569236	Bolt - 1/2" x 3/4"	3
9	569538	Bolt - M10 x 25	16
10	569664	Bolt - M10 x 40	2
11	569726	Plug - 1/8"	2
12	569948	Oil Line Fitting	2
13	575005	Shim End Cover - .001"	*
14	575006	Shim End Cover - .002"	*
15	575111	Dowel Pin - 6 X 24	4
16	968159	Flange – 1 1/2"	2
17	975536	Vane Pack	1
18	969207	End Cover	2
19.1	11063	Bolt - M8 x 25	2

Item	Code	Description	Qty
19.2	25059	Washer - M8	2
19.3	33502	Oil Tank Bracket	1
19.4	39111	Oil Tank Sticker	1
19.5	504278	Nut - M8	2
19.6	569209	Oil Tank - 1.5 Quart	1
19.7	969217	Dripper Housing	1
19.8	569146	Dripper	2
19.9	569212	Dip Tube	1
19.10	569213	Dripper Clamp Ring	1
19.11	504264	Grub Screw - M5 x 6	2
19.12	569216	Bolt - M4 x 20	2
19.13	569214	Dripper Clamp Gasket	1
19.14	569947	Oil Line Fitting	2
19.15	600293	Oil Line	*
19.16	503054	Cable Tie	1
20	969223	Rotor Assembly	1
21	969237	Shaft Cover	1
22	975476	Flange - Blank	2
23	975541	Cylinder	1

Notes: * Quantities Vary

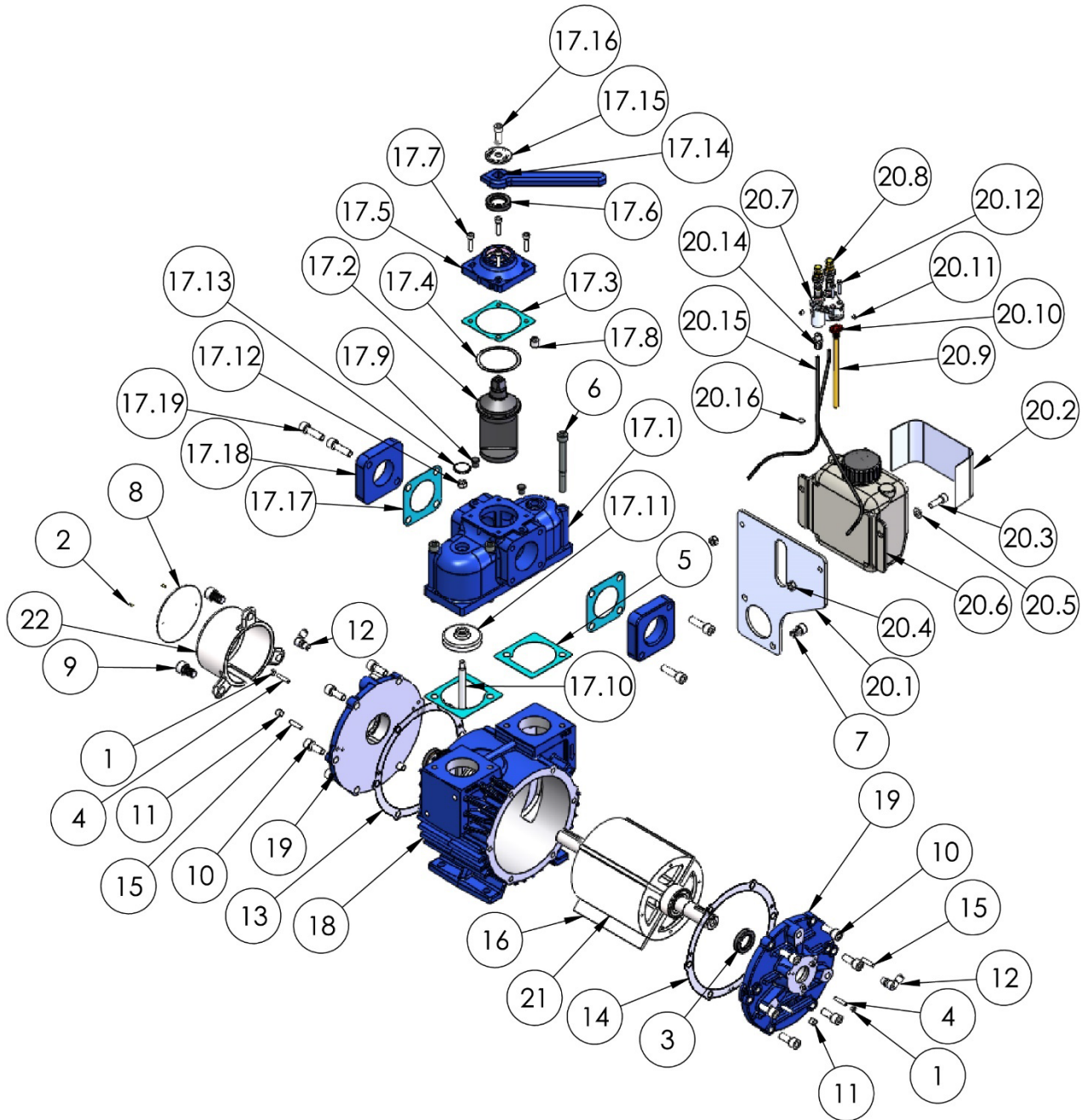
HD3V:

Item	Code	Description	Qty
1	220221	Nut - M5	6
2	500806	Rivet - 2.5 X 6	2
3	501578	Seal - 25 x 40 x 8	2
4	503225	Grub Screw - M5 x 20	6
5	568066	Gasket – Valve	2
6	568249	Bolt - M10 x 100	4
7	569218	Bolt - M10 x 16	2
8	569234	Pump Model Tag	1
9	569236	Bolt - 1/2" x 3/4"	3
10	569538	Bolt - M10 x 25	12
11	569726	Plug - 1/8"	2
12	569948	Oil Line Fitting	2
13	575005	Shim End Cover - .001"	*
14	575006	Shim End Cover - .002"	*
15	575111	Dowel Pin - 6 X 24	4
16	968236	Vane Pack	1
17.1	968359	Valve Body	1
17.2	968362	Spool	1
17.3	568063	Gasket - Valve Cap	1
17.4	568363	Wave Washer	1
17.5	968364	Valve Cap	1
17.6	501578	Seal - 25 x 40 x 8	1
17.7	11049	Bolt - M6 x 25	4
17.8	503416	Plug - 1/4"	1
17.9	568892	Rubber Plug	2
17.1	568343	Shoulder Bolt	1
17.11	968353	Non-Return Valve	1
17.12	504278	Nut - M8	1

Item	Code	Description	Qty
17.13	504288	Plug	1
17.14	668055	Valve Handle	1
17.15	569724	Indicator Washer	1
17.16	11063	Bolt - M8 x 25	1
17.17	36202	Gasket - Flange"	2
17.18	968159	Flange - 1 1/2"	2
17.19	501966	Bolt - M10 x 55	4
18	969203	Cylinder	1
19	969207	End Cover	2
20.1	33502	Oil Tank Bracket	1
20.2	39111	Oil Tank Sticker	1
20.3	11063	Bolt - M8 x 25	1
20.4	504278	Nut - M8	2
20.5	25059	Washer - M8	2
20.6	569209	Oil Tank - 1.5 Quart	1
20.7	969217	Dripper Housing	1
20.8	569146	Dripper	2
20.9	569212	Dip Tube	1
20.10	569213	Dripper Clamp Ring	1
20.11	504264	Grub Screw - M5 x 6	2
20.12	569216	Bolt - M4 x 20	2
20.13	569214	Dripper Clamp Gasket	1
20.14	569947	Oil Line Fitting	2
20.15	600293	Oil Line	2
20.16	503054	Cable Tie	1
21	969233	Rotor Assembly	1
22	969237	Shaft Cover	1

Notes: * Quantities Vary

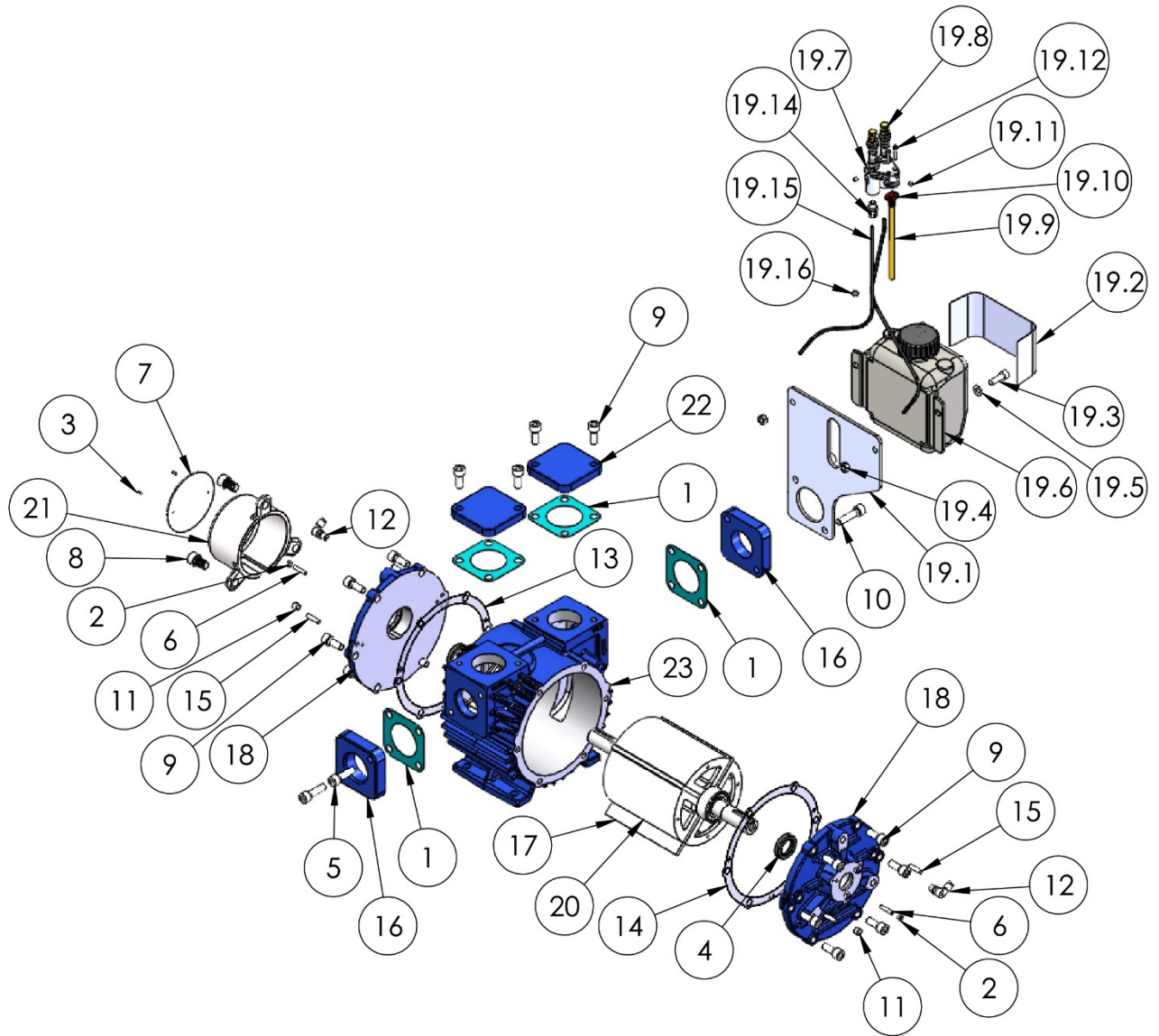
HD3F:

Item	Code	Description	Qty
1	36202	Gasket – Flange	4
2	220221	Nut – M5	6
3	500806	Rivet - 2.5 X 6	2
4	501578	Seal - 25 x 40 x 8	2
5	501966	Bolt – M10 x 35	2
6	503225	Grub Screw - M5 x 20	6
7	569234	Pump Model Tag	1
8	569236	Bolt - 1/2" x 3/4"	3
9	569538	Bolt - M10 x 25	16
10	569664	Bolt - M10 x 40	2
11	569726	Plug - 1/8"	2
12	569948	Oil Line Fitting	2
13	575005	Shim End Cover - .001"	*
14	575006	Shim End Cover - .002"	*
15	575111	Dowel Pin - 6 X 24	4
16	968159	Flange – 1 1/2"	2
17	975536	Vane Pack	1
18	969207	End Cover	2
19.1	33502	Oil Tank Bracket	1

Item	Code	Description	Qty
19.2	39111	Oil Tank Sticker	1
19.3	11063	Bolt - M8 x 25	1
19.4	504278	Nut - M8	2
19.5	25059	Washer - M8	2
19.6	569209	Oil Tank - 1.5 Quart	1
19.7	969217	Dripper Housing	1
19.8	569146	Dripper	2
19.9	569212	Dip Tube	1
19.10	569213	Dripper Clamp Ring	1
19.11	504264	Grub Screw - M5 x 6	2
19.12	569216	Bolt - M4 x 20	2
19.13	569214	Dripper Clamp Gasket	1
19.14	569947	Oil Line Fitting	2
19.15	600293	Oil Line	*
19.16	503054	Cable Tie	1
20	969233	Rotor Assembly	1
21	969237	Shaft Cover	1
22	975476	Flange - Blank	2
23	975551	Cylinder	1

Notes: * Quantities Vary

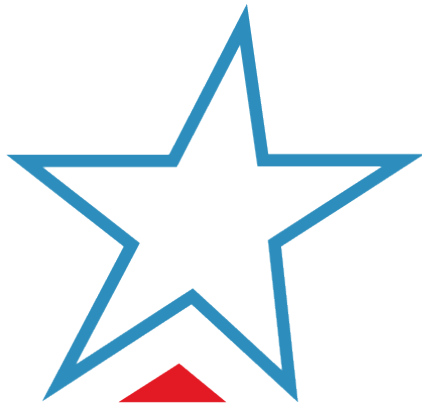

MASPORT

BUILT TO WORK AS HARD AS YOU DO

www.masportpump.com
