

PRO-VAC



INDUSTRIAL PUMPOUT STATION



Vacuum Technology

OPERATIONS MANUAL

Congratulations on the purchase of your new ProVac Industrial Pumpout Station. Your new ProVac has been manufactured with the best quality components to give you year after year of trouble free service. As you can easily see, it is built to withstand the most extreme conditions. Nevertheless, you will find that your ProVac will continue to give you “brand new” performance by following some simple maintenance procedures.

PRE-OPERATION SETUP

Your ProVac has been completely tested at the factory before you have taken delivery of it. All systems have been checked and rechecked to make sure that everything is working properly and is set up to work right out of the crate. However, due to federal regulations, it is not possible to ship the unit to you with oil in the vacuum pump reservoir. **It is, therefore, imperative for you to add oil to the oil reservoir before starting the unit. Failure to do this can damage the vacuum pump and void the vacuum pump warranty.** To make sure the oiling system is set up properly, follow the instructions below:

First, fill the oil reservoir (item #9) 1.0” from the top. Oil reservoir is located next to the Conde vacuum pump (see picture page # 7). Use a synthetic blend (S.A.E.) 10W-30 motor oil. Synthetic oil will keep the inside of the pump cleaner than standard motor oil, and we recommend it. **Always maintain oil level so it is visible in the sight tube.**

The ProVac system utilizes a trouble free, no-adjustment-required Conde wick oiling system. After the oil reservoir is filled no adjustment is required..

Remember, it is important that the Conde vacuum pump always receives a supply of oil when it is in operation. Therefore, check the oil reservoir periodically to insure that the pump will be getting oil while it is running. Oil level can be seen in oil reservoir sight tube.

WARNING: The ProVac should not be used for pumping flammable liquids or gasses.

OPERATION

The ProVac is simple to operate. The complete unit comes with a 60 gallon tank on a frame with wheels, a Conde vacuum/pressure pump, motor reversing control, electronic float shut-off, brake assembly, retractable cord reel, tool holder, hose and wand. Please see the enclosed complete parts list (pages 7-8) to identify all items on your ProVac. Your ProVac will be made of steel or aluminum.

After filling the oil reservoir as previously discussed, to operate the ProVac, plug it into any 115 volt, 15 amp or higher wall circuit. Before plugging in the ProVac, make sure that the switch on control box (item #16) is in the "off" position. Also, make sure that all covers and fittings are tightly secured. **If the ProVac is turned on in the pressure mode, loose or insecure fittings can blow off and serious injury can result.**

Now turn the 2" outlet ball valve (item #8) located on the bottom of the tank to the "off" position and turn the 2" inlet ball valve (item #4) located on the top front of the tank to the "off" position also. This will allow the tank to build up vacuum when the unit is turned on. It is also a good idea to close the 2" ball valve on the wand assembly at this time.

The Vacuum or Suction Mode

To begin pumping in the suction mode, turn the position switch on the control box (item #16) to the vacuum position which is marked as such on the control box. The pump will start and will immediately begin to build vacuum. This can be ascertained by looking at the gauge (item #12) located on the front of the ProVac. The gauge is a combination vacuum/pressure gauge, so first make sure the gauge is reading in the vacuum mode. Vacuum is measured by inches of mercury (shown as "Hg") on the gauge. The ProVac is equipped with a vacuum relief valve (item #6) that will allow the unit to build up to 16" Hg, which is enough vacuum to do virtually any job. After the ProVac has built up 16" Hg, the vacuum relief valve will begin to crack and pull atmospheric air into the tank. It will sound as if the unit is leaking, but this is perfectly normal. To begin pumping, open the 2" inlet ball valve (item # 4). Next place the wand into the liquid to be pumped and open the wand assembly 2" ball valve. Pumping will be instantaneous and at a rate of about 120 gallons per minute which means, of course, that it will take only about 30 seconds to fill the ProVac.

The ProVac is equipped with an electronic float shut-off that will shut the ProVac unit off when it is full. It is not possible to overfill the ProVac because the float shut-off will cut the power off to the pump module when the tank is full, preventing any moisture or foreign substance from being sucked inside the pump. If, while pumping, the unit suddenly shuts off, it is full.

In some cases, it will not be possible to use the wand assembly because it will be too long to fit into the area to be pumped. In these cases, pumping vacuum can be achieved in the tank by turning off the 2" inlet ball valve (item #4) located on the top front of the tank. Then, simply put the 2" hose, less the wand assembly, into the liquid to be pumped and open the 2" inlet ball valve (item #4) at top of the tank. When pumping is complete, turn the 2" inlet ball valve at the tank to the "off" position, and turn the controller off.

Sometimes, to be able to pump only small amounts of liquid that remain on the bottom of a tank, it is necessary to increase the velocity of air flow. In these circumstances, the unit is pumping both air and liquid. In most instances, it is important to keep the wand submerged in the liquid at all times to maintain tank vacuum at 16" Hg for maximum speed pumping. However, for small amounts of liquid, air velocity can be increased by closing the wand assembly ball valve to about half way to three quarters. This will increase air flow so that air and water can be pumped at the same time.

Pressure or Off-Load Mode

The ProVac is equipped with pressure off-loading capacity. For safety considerations, the ProVac pressure relief valve is factory set to off-load at a maximum of 5 psi. This will offload waste approximately 10 feet high. Higher off load capabilities are possible by adjusting the pressure relief valve (item #14). **The pressure relief valve should never be adjusted to over 10 psi.**

Before attempting to run the ProVac in the pressure or off-load mode, make sure all the fittings and valves are securely closed. Severe injury may result if fittings are not secure when the ProVac is in the pressure mode.

To off-load the ProVac, detach the 2" suction hose from the quick disconnect at the 2" inlet ball valve (item #4). First make sure that the 2" inlet ball valve is **closed** as is the 2" outlet ball valve (item #8). Reattach the 2" suction line to the discharge ball valve, attach or move the hose to the vessel to receive the contents of the ProVac, and open the discharge ball valve. Now, turn the position switch (item #16) on the control box to "pressure". It is possible to verify that the ProVac is in the pressure mode by observing the gauge (item #12) located on the front of the unit. The gauge should now show pressure rising in the tank and the needle should read pressure or "PSIG". The ProVac will build only enough pressure to completely off load the unit. If, on the other hand, the unit is turned on to the pressure mode first before opening the discharge ball valve, the unit will begin to build pressure until the pressure relief valve (item #14) on top of the tank opens and begins to relieve air to atmosphere.

The unit can also be off-loaded by attaching a suction line to the 2" outlet ball valve (item #8) from another vacuum pumping source, such as a vacuum truck.

Before pumping out the ProVac unit with another source, make sure that the 2" inlet ball valve (item #4) is open to provide a vent for pumping.

Cleaning and Maintenance

The easiest way to keep the inside of the ProVac tank clean, is to pump clean water into the tank using the wand and hose attachment. In this way, all parts of the ProVac that are normally exposed to waste are cleaned by the water. Immediately, after filling the tank with water, off-load the unit as previously explained into an appropriate container.

Your ProVac is equipped with two large 6" manway openings located in the lower back of the tank and on the top. These openings enable you to get inside the tank itself to remove any debris that might have been sucked into the unit. It is also possible to use the opening to spray out the unit. To remove cover, simply unscrew the eight hex bolts and lift off cover. When replacing the cover, be sure that the O-ring is properly seated.

CAUTION: Do not remove any fittings while unit is under pressure. Severe injury could result. Check gauge first to make sure gauge reads zero.

ELECTRONIC SHUT-OFF

You will find that the electronic float shut-off (item #13) on your ProVac is designed so that it is easily removed from the tank for cleaning. To remove the electronic float switch assembly, simply remove the four bolts that hold it in place and pull the whole assembly out of the tank. Make sure the o-ring is in place for reassembly.

OIL CATCH MUFFLER

The oil catch muffler (item #17) is designed to capture oil as it exits the exhaust of the Conde pump. It is necessary to periodically drain the oil catch by turning the petcock located at the bottom of the oil catch muffler. Always dispose of used oil in a responsible way.

Do not put used oil from the oil catch muffler back into the oil reservoir.

EXHAUST DEODORIZER

Your ProVac is equipped with an exhaust deodorizer (item #7). This is designed to reduce odors from the tank which may be exhausted through the vacuum pump when the unit is in the vacuum or suction mode. The odor control deodorizer is made to be completely and easily disassembled for maintenance. The deodorizer uses activated charcoal granules to absorb odors rather than trying to "cover up" unwanted odors with a perfume-like fragrance. After a period of time, it will become necessary to replace the activated charcoal. Simply remove clamp and bottom canister, dispose of the old charcoal, and add new charcoal. If the foam elements are not in their proper places, it is possible to suck charcoal into the vacuum pump. If this does happen, immediately flush out the pump with kerosene. Activated charcoal is readily available at most hardware stores. If you have trouble locating replacement charcoal, call Westmoor, Ltd.

FLUSHING INSTRUCTIONS - As preventative maintenance it is recommended to flush the pump periodically, depending on its use.

However unlikely, it is possible that liquid may be inadvertently sucked into the pump while pumping. If this occurs, flush the pump out with kerosene or diesel fuel immediately. If there is liquid in the secondary trap bowl, flush pump immediately.

Never under any circumstance flush out the pump with gasoline or any other highly flammable substance.

Before flushing procedure (so you do not contaminate activated charcoal and filter elements) remove clamp and bottom canister on deodorizer. (item #7).

To flush the pump, utilize the brass flushing petcock (item #10) located on the top front of the pump. Attach a small line from the petcock to a small cup of kerosene. Turn the pump on in the vacuum or suction mode, and open the petcock. Even though the vanes inside the pump may be stuck in the rotor slots, a small amount of vacuum should draw kerosene into the pump and out the exhaust. Continue to suck kerosene into the pump until the vanes become free which can be audibly detected, and the pump is able to reach full vacuum (16" Hg). After flushing the pump, drain the kerosene out of the oil catch muffler and turn the unit back on in the vacuum mode and run for two minutes.

Note: This is done to lubricate the pump after flushing.

After flushing procedure, reassemble odor deodorizer.

Note: Serious corrosion problems caused by liquid or other foreign substance entering the pump may require complete disassembly and rebuilding of the pump.

TROUBLE SHOOTING YOUR PROVAC

Problem	Solution
- Unit turns on, but will not build up vacuum	- Pump needs flushing
	- Exhaust/oil-catch or deodorizer plugged
	- Check to see that all valves are closed
- Unit builds vacuum, but will not pump	- Hose is clogged with debris. Turn unit off, detach suction line and reattach turning it end for end. Turn on unit in vacuum mode to dislodge debris

Problem

Solution

- | | |
|--|--|
| <ul style="list-style-type: none">- In the pressure mode, unit builds pressure, but will not off-load
- Pump is overheating
- Control Switch (vacuum or pressure position) motor does not start

- Unit will not shut off when full
- Motor will start in vacuum not pressure
- Motor will start in pressure not vacuum

- Kicking out 15 amp service

- Pump not getting oil | <ul style="list-style-type: none">- Make sure the discharge line is open. Detach hose and reverse it end for end in the event the hose is clogged. Make sure the off-load head is not more than 10 feet.
- Pump is not getting sufficient oil. Check oil level in reservoir and fill to proper level.
- Check power supply- Reset on cord reel- Reset on motor- Faulty contactor

- Faulty float switch
- Faulty contactor

- Tank full- Faulty float switch- Faulty contactor

- Relief valve set too high, readjust to 16" Hg

- Low oil level- Not recommended oil- Wick assembly needs replacing |
|--|--|

Thanks again for your purchase. We at Westmoor, Ltd. sincerely feel that we have the best portable liquid waste unit available on the market today.

PRO-VAC

INDUSTRIAL PUMPOUT STATION

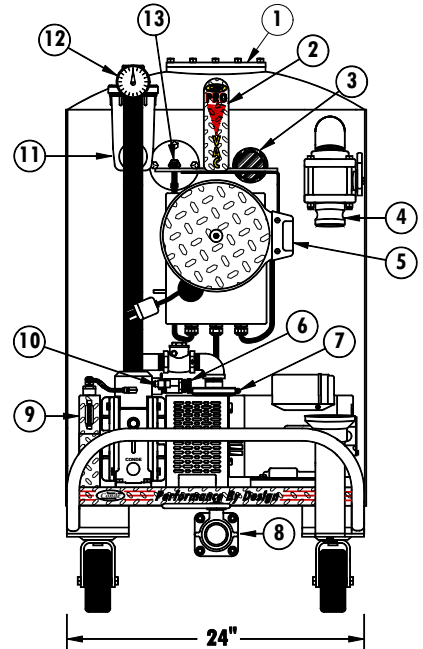
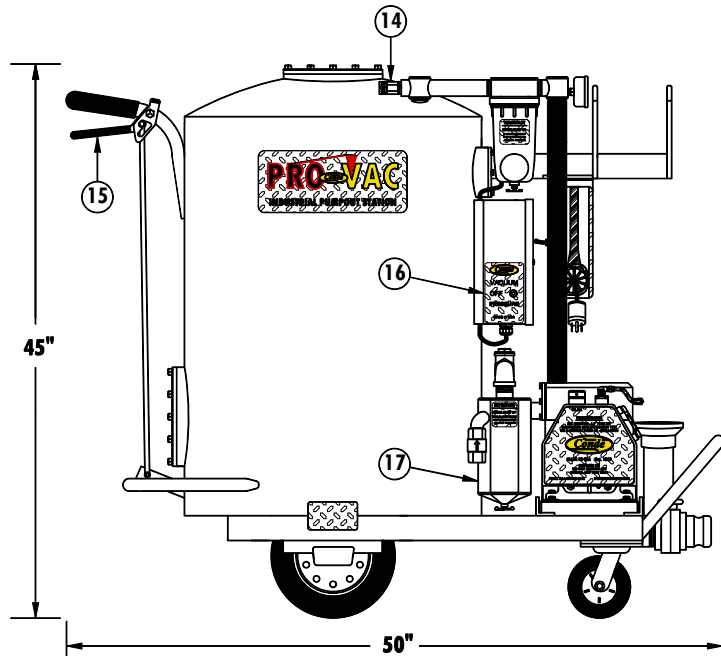

PART NO.

LWUNP60A10 - PROVAC 60 GALLON (ALUMINUM) UNIT

LWUNP6010 - PROVAC 60 GALLON (STEEL) UNIT

DRY WEIGHT - ALUMINUM 250 LBS.
CR STEEL 325 LBS.

STANDARD FEATURES

LOWER OVERALL HEIGHT
2" FRONT SUCTION INLET & DISCHARGE OUTLET
25' RETRACTABLE CORD REEL
HOSE RACK & TOOL HOLDER
AUTOMATIC OILING SYSTEM
CONDE PROVAC VACUUM PUMP (35 CFM)
1-1/2 HP ELECTRIC MOTOR (115 VOLT/13.4 FLA)
ELECTRONIC FLOAT SHUTOFF
SECONDARY SHUTOFF W/ DRAIN
LIQUID FILLED VACUUM/PRESSURE GAUGE
OIL CATCH MUFFLER W/ DRAIN
CHARCOAL EXHAUST DEODORIZER
10 FT - 2" SUCTION HOSE W/ WAND ASSEMBLY
TWO - 6" CLEANOUT MANWAYS
HEAVY DUTY WHEELS & FRONT SWIVEL CASTERS
HAND / PARKING BRAKE
VACUUM & PRESSURE RELIEF VALVES
PUMP - FLUSH VALVE

NO. PART IDENTIFICATION

- 1 - CLEANOUT MANWAY
- 2 - HOSE RACK
- 3 - SIGHT GLASS
- 4 - INLET BALL VALVE
- 5 - CORD REEL
- 6 - VACUUM RELIEF VALVE
- 7 - EXHAUST DEODORIZER
- 8 - OUTLET BALL VALVE
- 9 - OIL RESERVOIR
- 10 - FLUSH VALVE
- 11 - SECONDARY TRAP
- 12 - VACUUM / PRESSURE GAUGE
- 13 - ELECTRONIC FLOAT SHUTOFF
- 14 - PRESSURE RELIEF VALVE
- 15 - BRAKE HANDLE
- 16 - ON / OFF CONTROL SWITCH
- 17 - OIL CATCH MUFFLER

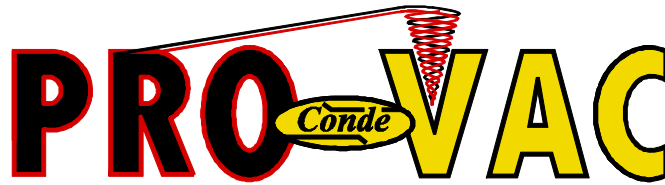

Conde Pumps
MADE IN THE USA

INDUSTRIAL PUMPOUT STATION

PARTS LIST

PART NO.	DESCRIPTION	PART NO.	DESCRIPTION
OL03PV KIT03PV PVMANIFOLD GSKPV03 GSKPV04	PROVAC PUMP (REPLACEMENT) PROVAC PUMP (REBUILD KIT) ALUMINUM PUMP MANIFOLD GASKET PUMP/MANIFOLD GASKET MANIFOLD/OILCATCH	LWFC015F LWFC01A LWSW02 1LC15 CORDR CORDRP	CONTOL BOARD (COMPLETE) CONTACTOR (ONLY) VAC/PRESS FLOAT SHUTOFF (TANK) WATERTITE CONNECTOR 25' CORD REEL CORD PLUG (MALE END)
MT1.5F PUCFL5J034 PUCFL5J058 PUCSL5JE KEY03 MTSP786.5 GRDC03	1-1/2 HP ELECTRIC MOTOR (115 V-13.4 FLA) PUMP - DRIVE COUPLING MOTOR - DRIVE COUPLING RUBBER INSERT FOR DRIVE COUPLING 3/16" SHAFT KEY ALUMINUM MOTOR RISER/SPACER DRIVE COUPLING GUARD	OR231 OR259 LWTR02 LWTR02A LWTR02B 1BA200B GAGE016 HOSELWP114	O-RING (TANK FLOAT CONNECTION) O-RING (CLEANOUT) PLASTIC SECONDARY TRAP (COMPLETE) SECONDARY TRAP (TOP CAP) SECONDARY TRAP (CLEAR BOWL) FLOAT BALL VACUUM/PRESSURE GAUGE 1-1/4" I.D. HOSE (VACUUM/PRESSURE)
TO03PVUNIT EDMP02A TO016 PF229-4-2 TO008PVA RWPATUB025A PF170P-4-2 PF169P-4-2 PFCVB018A	OIL RESERVOIR (COMPLETE) VENTED FILL PLUG FOR RESERVOIR 1/4" I.D. CLEAR SIGHT TUBE BRASS BARBED ELBOW FOR SIGHT TUBE BRASS JET ORIFICE & WICK ASSEMBLY 1/4" O.D. OIL FEED TUBE BRASS POLYTITE ELBOW (FEMALE) BRASS POLYTITE ELBOW (MALE) 1/8" IN-LINE OIL TUBE CHECK VALVE	LWBH01 LWBH02 LWW10 FSC100 LWCA05 LWSG21 LWVB200B LWVB200A LWHA10 LWWA15	BRAKE LEVER HANDLE BRAKE HANDLE LOCK 10" REAR WHEEL COTTER PIN / REAR WHEEL FRONT SWIVEL CASTER 2" SIGHT GLASS W/ O-RING 2" POLY BALL VALVE (INLET) TOP 2" POLY BALL VALVE (DISCHARGE) BOTTOM 2" X 10FT PLASTIFLEX HOSE ASSEMBLY WAND ASSEMBLY (ONLY)
RVP10 RVP10P SV124 TO008	BRASS - VACUUM RELIEF VALVE BRASS - PRESSURE RELIEF VALVE BRASS PETCOCK (FLUSH VALVE) BRASS HOSE BARB (FLUSH VALVE)		
MFOC3PV LWDE00 LWDECH1 LWDEFLT1 LWDE01A 1SS321630 1SS321030 PFCV100 PFCVBC075A	OIL CATCH MUFFLER EXHAUST DEODORIZER (COMPLETE) REPLACEMENT CHARCOAL FOAM ELEMENT (2 REQUIRED) SCREEN FOR DEODORIZER TOP CLAMP FOR DEODORIZER GASKET FOR DEODORIZER 1" BRASS CHECK VALVE (BETWEEN OIL CATCH / DEODORIZER) 3/4" POLY CHECK VALVE (MOUNTED ON OIL CATCH)		
<p>SALES</p> <p>CUSTOMER SERVICE & TECHNICAL SUPPORT</p> <p>WESTMOOR LTD. 906 WEST HAMILTON AVE SHERRILL, NEW YORK 13461</p> <p>PHONE: 800-367-0972 FAX: 315-363-0193</p> <p>www.westmoorltd.com E-mail: pumps@westmoorltd.com</p> <p>Manufacturer of: Conde Pumps Est. 1939</p>			



Westmoor Ltd.

906 West Hamilton Ave.
Sherrill, New York 13461

800-367-0972

www.westmoorltd.com

FAX: 315-363-0193



Vacuum Technology